

**ROTARY MICROTOME**  
**HM 350 S / HM 350 SV**  
**INSTRUCTION MANUAL**

# Rotary Microtome HM 350 S / HM 350 SV

**CERTIFICATION**

MICROM International GmbH certifies that this instrument has been tested and checked carefully. Its technical data was verified before shipment to be in accordance with the published specifications.  
The instrument complies with applicable international safety regulations.

**WARRANTY**

This MICROM product is warranted against defects in material and workmanship for a period of 1 year. Parts which prove to be defective during the warranty period will be repaired or replaced free of charge by MICROM International GmbH. No other warranty is expressed or implied. Unauthorized modification or repair by third party persons will void the warranty.  
The warranty will expire in case of improper or wrong use of the instrument and in case the warning and precautionary messages are not observed. MICROM International GmbH is not liable for any occurring damage.

Errors and omissions excepted. Subject to amendment and improvement without further notice.

This instruction manual will be supplied together with each instrument. Further copies can be ordered at the nearest MICROM sales office by giving the serial number of the instrument, the number of the instruction manual and the date of issue.

This instruction manual is available in the following languages:

	Cat. No.
German:	387 694
English:	387 695
French:	387 696
Spanish:	387 709

# Rotary Microtome HM 350 S / HM 350 SV

**INTENDED USE**

Dear Customer,

Before operating the instrument, please read these instructions carefully to familiarize yourself with its proper operation and functions.

Only skilled or specially trained personnel must operate the microtome, i.e. clamping the specimen, trimming, sectioning and taking off the sections from the instrument. The listed and marked safety measures as well as the regulations of your respective lab must be strictly observed.

---

---

**MICROM-Ser. No.:** .....

Please enter the serial number, which is placed on the type plate on the rear side of the instrument. This way, questions and service can be handled faster.

Instruction Manual No. 387 695

Issued on September 28, 2005

<p><b>MICROM International GmbH</b> <b>Robert-Bosch-Strasse 49</b></p> <p><b>D-69190 Walldorf</b></p> <p><b>Telefon: (06227) 836-0</b> <b>Telefax: (06227) 836-111</b></p>
--

## **EC Certificate of Conformity**

**Name and address of the manufacturer:** MICROM International GmbH  
Robert-Bosch-Straße 49  
D-69190 Walldorf

**Product designation:** Rotary Microtome  
**Type reference:** HM 350 S (V)

**Notification to Competent Authorities:**

These medical device have been registered with the German authority as "Microtomes" under the EDMA-classification code: 23-06-02

The designated product complies with the laid down regulation:

**DIRECTIVE 98/79/EC OF THE EUROPEAN PARLIAMENT AND OF THE COUNCIL  
of 27 October 1998  
on in vitro diagnostic medical devices**

The designated product complies with the EC regulations by strictly observing the following norms:

**DIN EN ISO 14971:2001-03**

Medical devices - Application of risk management to medical devices (ISO 14971:2000).

**DIN EN 61010-1:2002-08**

Safety requirements for electrical equipment for measurement, control and laboratory use - Part 1: General requirements (IEC 61010-1:2001).

**DIN EN 61010-2-101:2003-09**

Safety requirements for electrical equipment for measurement, control and laboratory use - Part 2-101: Particular requirements for In-Vitro-Diagnostic-(IVD)-Medical instruments.

**DIN EN 61010-2-081:2002-12**

Safety requirements for electrical equipment for measurement, control and laboratory use - Part 2-081: Particular requirements for automatic and semi-automatic laboratory equipment for analysis and other purposes (IEC 61010-2-081:2001).

**DIN EN 61326:2002-03**

Electrical equipment for measurement, control and laboratory use - EMC requirements (IEC 61326-1:1997 + A1:1998 + A2:2000); German version EN 61326:1997 + A1:1998 + A2:2001

**DIN EN ISO 9001:2000**

Quality management systems - Requirements (ISO 9001:2000)



---

Hans Heid  
Managing Director

Walldorf, 10 February 2004

## TABLE OF CONTENTS

### Intended use

### EC Certificate of Conformity

### Safety precautions

## Part 1 Introduction

- 1-1 Description of the Rotary Microtome HM 350 S / HM 350 SV
- 1-2 Technical specifications HM 350 S / HM 350 SV

## Part 2 Operating instructions

- 2-1 Setting up the microtome
- 2-2 Initial turn-on
- 2-3 Cutting movement and retraction
  - 2-3-1 Selection of transmission of turning knobs
- 2-4 Setting section thickness and trimming thickness
- 2-5 Specimen feed
  - 2-5-1 Coarse feed and speed for coarse feed
  - 2-5-2 Trimming and first cuts
  - 2-5-3 Fine feed
- 2-6 Motorized cutting drive
  - 2-6-1 Setting cutting window
  - 2-6-2 Selection of operating modes
  - 2-6-3 Setting cutting speed
  - 2-6-4 Start and stop of cutting drive
  - 2-6-5 Cutting drive brake
  - 2-6-6 Emergency stop
- 2-7 Indication of cutting processes
  - 2-7-1 Section counter
  - 2-7-2 Sum of section thicknesses
  - 2-7-3 Remaining travel to front end position
- 2-8 Turning off the function <retraction>
- 2-9 Selecting the indicated language

## Rotary Microtome HM 350 S / HM 350 SV

- 2-10 Specimen clamping
  - 2-10-1 Universal cassette clamp
  - 2-10-2 Standard specimen clamp
  - 2-10-3 Insert for round specimens, V-insert and V-distance piece
  - 2-10-4 Foil clamp
  - 2-10-5 Segment arc and universal specimen holder
  
- 2-11 Adapters for specimen clamping
  - 2-11-1 Non-orienting adaptation
  - 2-11-2 Adapter, orienting, specimen holder with zero-orientation
  - 2-11-3 Changing and/or clamping specimen clamps
  - 2-11-4 Readjusting specimen clamps with orienting adapter
  
- 2-12 Knife carriers
  - 2-12-1 Solidly integrated Disposable blade carrier ERF
  - 2-12-2 Disposable blade carrier E
  - 2-12-3 Disposable blade carrier ER
  - 2-12-4 Standard knife carrier N
  - 2-12-5 Knife carrier C
  - 2-12-6 Knife carrier S
  - 2-12-7 Readjusting the knife carriers E, ER, N and C (removable versions)
  - 2-12-6 Readjusting the knife carrier S (removable version)
  
- 2-13 Storage unit
  
- 2-14 Memory function
  
- 2-15 Standard equipment
  
- 2-16 Additional equipment (optional)
  - 2-16-1 Knife carriers
  - 2-16-2 Specimen clamps
  - 2-16-3 Microtome knives
  - 2-16-4 Additional accessories

### **Part 3 Theory of operation**

- 3-1 Cutting movement and retraction
- 3-2 Specimen coarse feed and trimming function
- 3-3 Operating panel and foot pedal
- 3-4 Specimen clamping system and specimen orientation
- 3-5 Knife carriers
- 3-6 Microtome with freezing unit

**Part 4 Working with the microtome**

- 4-1 Preparation and orientation
- 4-2 Coarse feed and trimming function
- 4-3 Sectioning instructions
  - 4-3-1 Condition of the knife edge
  - 4-3-2 Clean knife surfaces
- 4-4 How to avoid malfunctions
  - 4-4-1 Preparation of the specimen
  - 4-4-2 Temperature of the specimen
  - 4-4-3 Tightening the clamping screws
  - 4-4-4 Selection of the knife
  - 4-4-5 Adjustment of the knife
  - 4-4-6 Cutting speed
  - 4-4-7 Trimming

**Part 5 Maintenance**

**Part 6 Cleaning and Care**

- 6-1 Cleaning
- 6-2 Disposal of the instrument after final shutdown

## SAFETY PRECAUTIONS

<b>CAUTION !</b>
------------------

**Please observe the following general precautions during operation of this instrument. Failure to comply with these precautions violates safety standards and the intended use of the instrument. MICROM International GmbH is not liable for misuse of the instruments and failure to comply with basic safety requirements.**

### INSTRUMENT GROUNDING

To avoid injury from electrical current, the instrument must be connected to the safety ground. The instrument is equipped with a three wire ground plug. The power outlet must be connected to the safety ground and must meet the International Electrotechnical Commission (IEC) regulations.

### CAUTION VOLTAGE

Never remove instrument covers during operation. Component replacement as well as adjustments must only be made by trained service personnel. Unplug the unit before removing or opening the covers.

### DANGER IN EXPLOSIVE ENVIRONMENT

The instrument must not be operated in the presence of flammable gases.

### CARE IN USING MICROTOME KNIFE



To diminish the danger of being injured by the knife or blade, use the knife guard when adjusting specimen and knife. If possible, the specimen should be clamped in before the knife is inserted into the knife carrier. Before changing the knife carrier, always remove blade or knife! Unused knives should always be kept in a knife case. Never try to catch a dropping knife! Never check the sharpness of the cutting edge with your fingers. The cutting edge is extremely sharp! Be careful when sectioning and/or removing sections.

### EMERGENCY STOP

Cutting movement can be stopped immediately by pressing the emergency stop. The emergency stop device is placed on the right upper side of the microtome. If the instrument is equipped with a foot pedal, a second emergency stop device is integrated there.

**CARE IN USING TURNING KNOBS FOR CUTTING DRIVE!**



Each movement on the turning knobs for the cutting drive leads to an up or downward cutting movement, i.e. the specimen clamping also moves up or downwards. For this reason, when manipulating on the turning knobs, it is absolutely necessary to avoid operations on the specimen clamping or on the knife carrier. The corresponding safety measures to avoid accidents must strictly be observed.

**HAZARD OF RADIOACTIVE RADIATION**

When working with radioactive specimens observe all applicable radiation safety procedures.

**HAZARD OF INFECTION**

Use the appropriate safety and disinfection measures when working with infectious specimens.

**HAZARD OF MALFUNCTION**

To avoid the hazard of malfunction of an instrument, it must only be operated in a controlled electromagnetic environment. This means, that transmitters such as mobile phones must not be operated in their close vicinity.

**HAZARD OF BIOLOGICAL DANGER**



Specimens used during the intended operation of the instrument might potentially be infectious. For this reason, it is recommended to observe the general laboratory regulations concerning protection against danger of infection.

Information on decontamination media, their use, dilution and effective range of application can be read in the Laboratory Biosafety Manual : 1984 of the World Health Organization.

## WARNING SIGNALS AND SYMBOLS

The installation and routine use of the HM 350 S/SV is easy and safe if the instructions in this manual are being observed.



**Note:**

Special instructions regarding operation of the instrument.



**Warning:**

Special precautionary measures to prevent damage to equipment. For a long lifetime of the equipment, please observe these instructions carefully.



**Caution – general danger spot:**

The instruction manual must strictly be observed whenever this symbol is visible on the instrument.



**Hazard of hand injuries:**

Due to moving parts in connection also with the microtome knife, a danger area arises, which might lead to hand injuries in case of non-compliance with the safety features of the microtome and when disregarding the instruction manual.

**Biohazard:**

Warning of biological danger.



**Radioactivity:**

Warning of radioactive danger.



**Chemicals:**

Warning of unhealthy or irritating substances.



**Separate taking back of electrical and electronic instruments in the countries of the European Union:**

This is to be applied in the countries of the European Union and other European countries with a separate collecting system within the waste management.

This product, being an electro and/or electronic instrument, must be treated separately within the waste management process (WEEE).

# Rotary Microtome HM 350 S / HM 350 SV

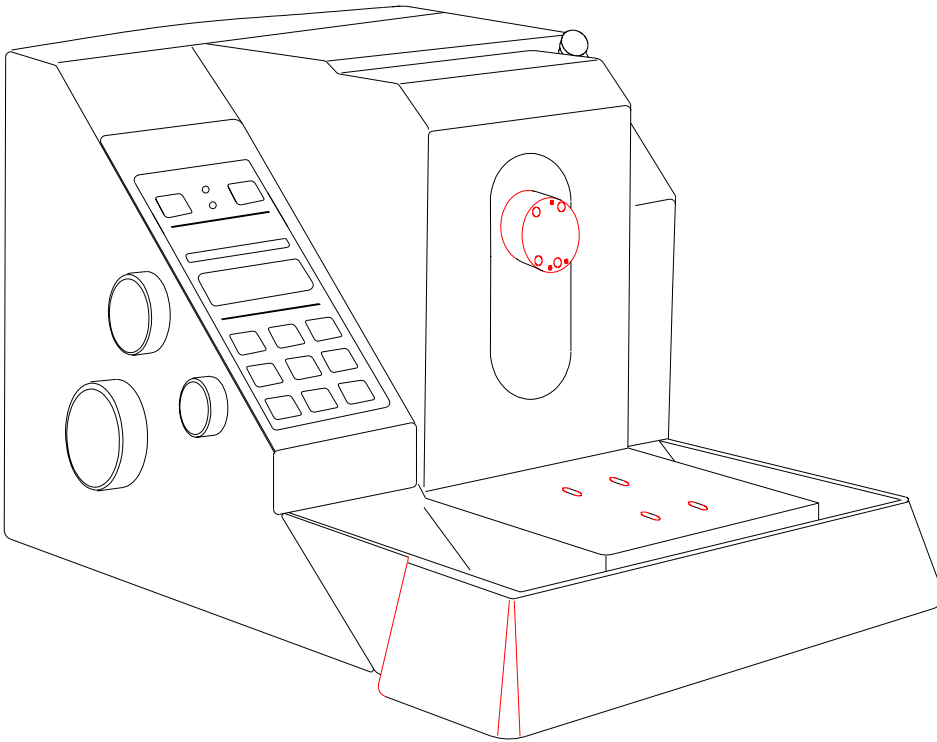

HM 350 S

Fig. 1a

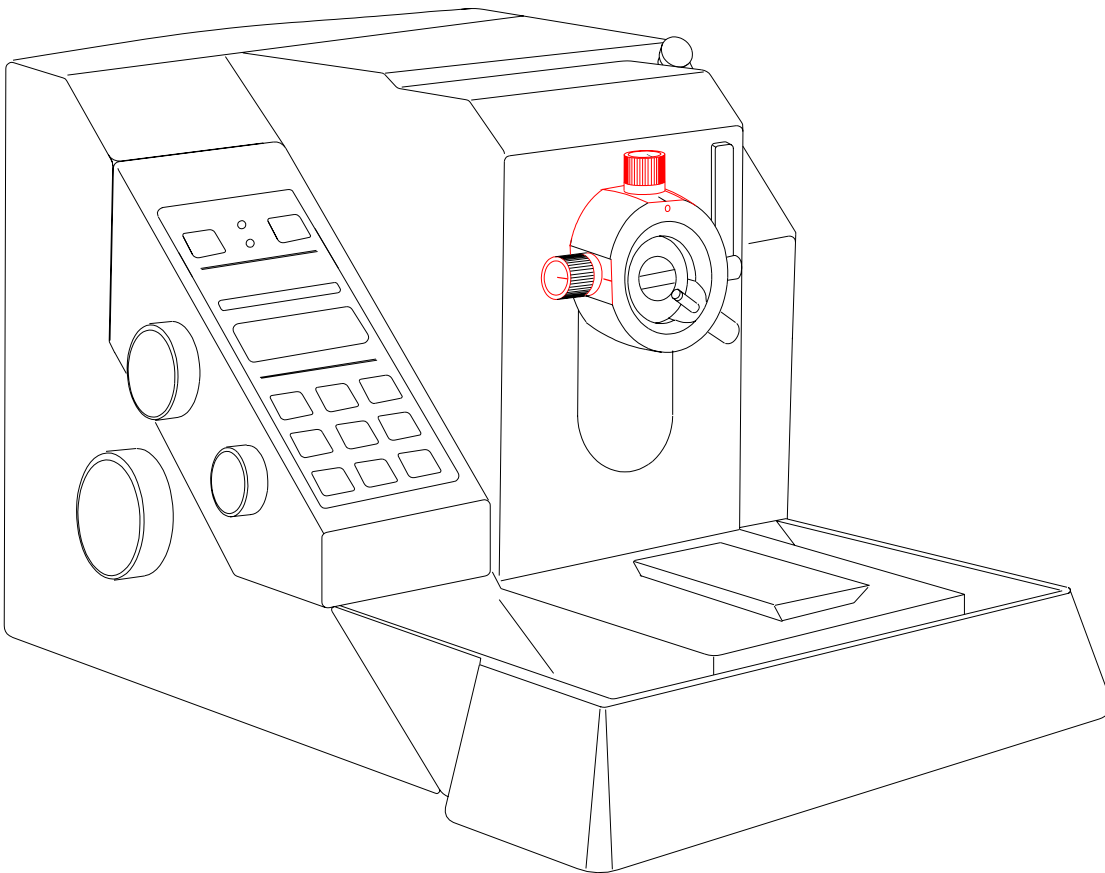

HM 350 SV

Fig. 1b

## PART 1 INTRODUCTION

### 1-1 DESCRIPTION OF THE ROTARY MICROTOME HM 350 S / HM 350 SV

The Rotary Microtome HM 350 S / HM 350 SV from MICROM International GmbH is a universal heavy duty microtome for all paraffin sectioning techniques in biology, medicine, industry and research.

The HM 350 S / HM 350 SV sets new ergonomical standards concerning operation and comfort. The instrument is equipped with an integrated section waste tray, which is built around the knife carrier for direct collection of section waste.

The Rotary Microtome HM 350 S / HM 350 SV is available in two different basic versions:

- HM 350 S** with integrated operating controls
- HM 350 SV** with removable operating panel that can be used separately

Moreover, it is possible to choose between a disposable blade carrier ER which is solidly integrated on the microtome or the knife carriers of the rotary microtome HM 3xx series.

In either case, the knife carriers are designed so the knives can be easily clamped in place and adjusted.

The specimen orientation offers another possibility to select. The instrument can be equipped with a non-orienting one or with the innovative zero-orientation.

These models can be equipped with all specimen clamps of the rotary microtome HM 3xx series. This also includes segment arc and universal specimen holder.

Further additional equipment for the HM 350 S / HM 350 SV is the storage unit with cooling insert for cassettes, brushes and tweezers.

The HM 350 S / HM 350 SV will cut sections in a range from 0.5 up to 100 microns. For the protection of knife and specimen, the instrument retracts the specimen at the end of the cut. If desired, the function <retraction> can be turned off.

The electronically controlled motor drive with precision tachogenerator guarantees an extremely fast adjustment to section force variations and constant cutting speed. It also ensures optimal section quality in each field of application. This results in a constant cutting speed over the entire cutting stroke.

The motorized coarse feed system allows both the continuous and graduated specimen forward and backward travel with three different speed settings. This way specimen and knife edge distance can be adjusted quickly.

A trimming function with defined steps from 5 to 500 microns permits the fine adjustment up to the first cuts and results in larger section thicknesses when trimming.

The operating panel is placed on the left side of the microtome.

The selected section thickness, trimming thickness, section counter, sum of section thicknesses and remaining travel to the front end position as well as the speed of the coarse feed and the speed of the cutting movement are indicated on the display of the operating panel.

## **Rotary Microtome HM 350 S / HM 350 SV**

As already described above, the basic instrument can be equipped with a removable (HM 350 SV) or a solidly integrated (HM 350 S) operating panel.

The removable operating panel can be used separately on either side of the instrument. For this, the operating knobs can be removed and installed on the other side of the operating panel.

The touchpad keyboard of both versions is clearly arranged for easy and safe operation.

For the user's safety, the instrument is equipped with an emergency stop device which is installed on the right upper side on the housing of the instrument.

If the instrument is equipped optionally with a foot pedal for the operation of the motorized cutting drive, another emergency stop device is integrated here.

## Rotary Microtome HM 350 S / HM 350 SV

**1 - 2**

### TECHNICAL SPECIFICATIONS HM 350 S / HM 350 SV

Microtome:	Section thickness range ..... 0,5 - 100 µm  Resolution: ..... 0,5 µm for 0,5 - 5 µm ..... 1 µm for 5 - 20 µm ..... 2 µm for 20 - 30 µm ..... 5 µm for 30 - 60 µm ..... 10 µm for 60 - 100 µm  Trimming thickness range ..... 5 - 500 µm  Resolution:..... 5 µm for 5 - 10 µm ..... 10 µm for 10 - 100 µm ..... 20 µm for 100 - 200 µm ..... 50 µm for 200 - 500 µm  Specimen retraction during return travel of the specimen ..... 40 µm Horiz. feed range ..... 28 mm Vertical specimen stroke ..... 50 mm
Section counter:	Five-digit LC display with reset
Sum of section thicknesses:	Five-digit LC display with reset
Remaining travel to front end position:	Five-digit LC display
Specimen size:	Standard ..... 55 x 40 mm
Specimen orientation, standard:	.....non-orienting
Specimen orientation, optional: x - and y - axes:	..... universal 8°, with zero detection
z - axis:	..... up to 360°
Cutting drive:	..... motorized, electronically controlled
Modes of operation:	..... interval, single, multi and continuous stroke
Cutting speed:	..... 10 - 400 mm/s
Coarse feed:	..... motorized, graduated and continuous
Speed for coarse feed:	.....400, 800 and 1200 µm/s
Storage temperature range:	..... -20°C to +50°C
Operating conditions:	..... +5°C to +40°C (at a max. rel. humidity of 60%) ..... altitude up to 2000 m M.S.L. ..... for indoor use only
Power requirements:	..... 220...230 V 0.8 A +/-10% 50...60 Hz ..... 240 V 0.8 A +/-10% 50...60 Hz ..... 100 V 1.6 A +/-10% 50...60 Hz ..... 115 V 1.6 A +/-10% 50...60 Hz
Pollution degree:	..... 2
Overvoltage category:	..... II
Dimensions:	..... 410x520x280 mm (wide/deep/high)
Weight:	..... 33 kg

## PART 2 OPERATING INSTRUCTIONS

### 2-1 SETTING UP THE MICROTOME

Unpack the microtome and remove the wrapping. On the lower side of the instrument towards the front and rear longitudinal axis, there are recessed grips to lift or carry the microtome.

**CAUTION!** The instrument must not be transported by the turning knobs (fig. 4.6).

Sectioning can be influenced by nearby instruments which generate vibrations. For this reason, the microtome should be placed on a stable and vibration free table. To move the unit on the table, lift the base slightly at the front end only and slide it.

Unpack the separate section waste tray (fig. 4.2) and install it from the front on the base plate.

**NOTE!** Remove the section waste tray to move or carry the instrument. The section waste tray can be pulled out of its proper position.

### 2-2 INITIAL TURN-ON

**CAUTION!** Before turning on the instrument for the first time, please check if the power requirements indicated on the type plate correspond to the power supply voltage being used.

The operating panel (fig. 4.1) of the rotary microtome **HM 350 SV**, which is separately packed, can be attached to the instrument or used freestanding. Firstly, connect the operating panel with the instrument. A 37-lead control cable (fig. 2b.1) is fixed on the rear side of the instrument. Connect this cable with the connector at the rear side of the operating panel.

Should the operating panel be attached to the instrument, push the 37-lead connector through the corresponding hole (fig. 2b.2) on the rear side of the microtome. Turn the connector 90° and push it through the hole on the front of the instrument. Plug the connector into the operating panel. Fasten the cable on the panel with the two screws. To clear away the cable, insert it into the corresponding holders (fig. 2b.3) on the rear side of the microtome.

As above-mentioned, the operating panel can be used freestanding. It can be placed on the left as well as on the right side of the microtome. For this, the operating knobs (fig. 4.3 and 4.4) can easily be removed and placed on the other side of the operating panel.

Rear view HM 350 S

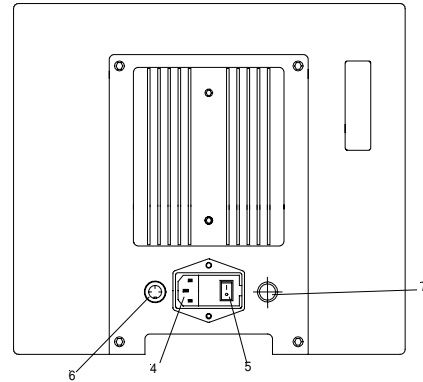

Fig. 2a

Rear view HM 350 SV

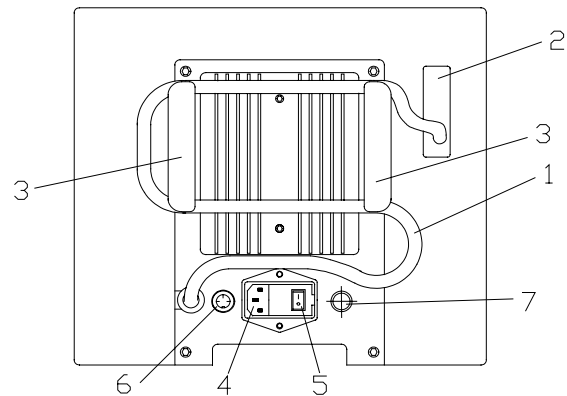

Fig. 2

Connect the 5-lead plug of the foot pedal cable into the outlet (fig. 2a/b.6) and tighten the swivel nut.

**NOTE!** If the foot pedal is not connected, there is the operating mode emergency stop (see part 2-6-6). This way, the cutting drive brake is activated and the cutting drive motor cannot be started. Always connect the foot pedal!  
In case the **foot pedal** is **not** part of the equipment, always insert the **interlock plug** into the socket (fig. 2a/b.6).

## Rotary Microtome HM 350 S / HM 350 SV

Connect the power cord to the power socket (fig. 2a/b.4) on the rear side of the instrument. Turn on the power switch (fig. 2a/b.5).

Then, the specimen holder moves to the rear end position. This movement is always carried out when the instrument is turned on. This way, the instrument is calibrated.

The insert for the two fuses is placed beside the power switch. The fuse for the motor supply (fig. 2a/b.7) is placed on the left side of the mains plug unit.

(See part 5, exchange of fuses).

The terms shown on the display are available in English, German and French. If desired, the user can change the language. (see part 2-9, selecting the indicated language).

## 2-3 CUTTING MOVEMENT AND RETRACTION

The cutting movement of the microtome is generated by the motorized cutting drive.

**NOTE!** The two turning knobs (fig. 4.6) on the right and left side of the instrument are used preferably for the first cuts and for trimming. Turning these knobs backwards leads to the cutting movement.

As the specimen moves down, sectioning is carried out (cutting movement, fig. 3.2). After passing the lower reversal point the specimen is brought back up. To protect the knife and specimen during return travel, the specimen is retracted (R). The yellow LED RETRACT (fig. 5.1) lights up. If desired, the function <retraction> can be turned off (see part 2-8, turning off the function <retraction>). The instrument is able to adjust the cutting range to the size of the specimen. This is called the cutting window.

X=selected section thickness  
 1=specimen  
 2=cutting movement  
 3=knife  
 4=return travel  
 R=retraction

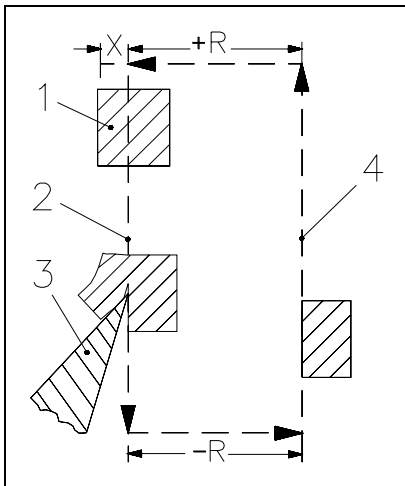

Fig. 3

**CAUTION!** To avoid the danger of being injured by sectioning, activate the cutting drive brake. During the activation of the motorized cutting drive, during the manual manipulation on the turning knobs and on the specimen holding device, please always use the cutting drive brake as well as the knife guards as precautionary measures.

### 2-3-1 SELECTION OF TRANSMISSION OF TURNING KNOBS

For a finer resolution of the vertical movement of the specimen clamping, it is possible to alter the speed coupling between turning knobs and specimen clamping. Then the specimen clamping moves with half the speed only.

For this, press the reset button (fig. 5.3) and while this button is still being pressed, additionally press button (fig. 5.13).

The display shows in the third line one of the two possibilities:

**MANUALSPEED: ->**

This means that a transmission ratio of 2:1 is selected, i.e. two turning knob rotations = one vertical movement of the specimen clamping.

or

**MANUALSPEED: -->>**

This means that a transmission ratio of 1:1 is selected, i.e. one turning knob rotation = one vertical movement of the specimen clamping.

Set the desired transmission ratio via button (fig. 5.2).

To confirm the selected transmission ratio, press the reset button (fig. 5.3). The basic indication is shown on the display.

## Rotary Microtome HM 350 S / HM 350 SV

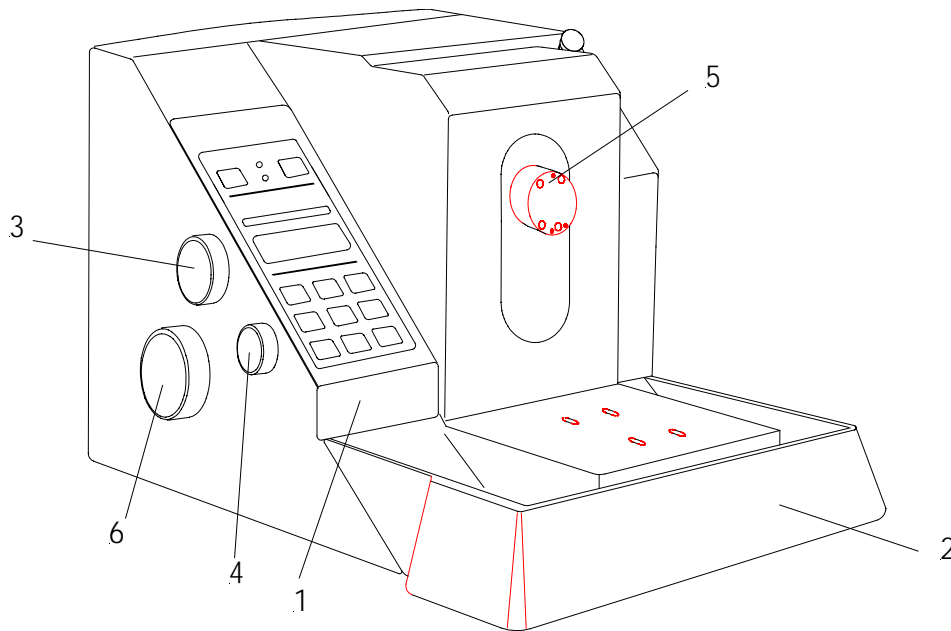

Fig. 4

### 2-4 SETTING SECTION THICKNESS AND TRIMMING THICKNESS

The required section and trimming thicknesses are set by means of the control knob (fig. 4.3), which is situated on the side part of the operating panel (fig. 4.1).

To choose between section thickness and trimming thickness, press the operating knob (fig. 4.3). A marking (fig. 5.5) in the first line of the display shows which cutting thickness is selected.

Switching over from trim sectioning to fine sectioning via the operating knob (fig. 4.3) can also serve to reduce the motorized cutting speed (see part 2-6-3).

If the trimming thickness is chosen, the LED in button (fig. 5.14) lights up in addition to the marking on the display.

After turning on the instrument, section thickness setting is automatically chosen and shown accordingly.

When turning the control knob, slight resistances can be felt. The selected values are shown in the second line on the display (fig. 5.7) of the operating panel.

"FEED" = selected section thickness

"TRIM" = selected trimming thickness

The graduation of the section thicknesses is divided into 5 ranges:

range	graduation
up to 5 $\mu$ m	0,5 $\mu$ m
from 5 $\mu$ m to 20 $\mu$ m	1 $\mu$ m
from 20 $\mu$ m to 30 $\mu$ m	2 $\mu$ m
from 30 $\mu$ m to 60 $\mu$ m	5 $\mu$ m
from 60 $\mu$ m to 100 $\mu$ m	10 $\mu$ m

The graduation of the trimming thicknesses is divided into 4 ranges:

range	graduation
up to 10µm	5µm
from 10µm to 100µm	10µm
from 100µm to 200µm	20µm
from 200µm to 500µm	50µm

## 2-5 SPECIMEN FEED

### 2-5-1 COARSE FEED AND SPEED FOR COARSE FEED

For the fast forward and backward travel between specimen and knife edge, the microtome has a motorized coarse feed system. The specimen holder is moved forwards as long as the button <coarse feed forwards> (fig. 5.16) is pressed. To move the specimen holder backwards, press the button <coarse feed backwards> (fig. 5.15).

The instrument carries out movements of various lengths according to how long the button (fig. 5.15) is pressed. Press the button (fig. 5.15) only very briefly and the specimen holder moves backwards by a fixed value of 2 µm. If the button (fig. 5.15) is pressed a little bit longer (not longer than 2 seconds), the specimen holder moves backwards as long as the button (fig. 5.15) is being pressed. If the button (fig. 5.15) is pressed for more than 2 sec., the specimen holder moves automatically to the back end position and the motorized coarse feed shuts off. This function can be stopped at any time. For this, shortly press the button (fig. 5.15) again.

When the back end position is reached, the red LED in button (fig. 5.15) lights up.

When the front end position of the specimen movement is reached, the red LED in button (fig. 5.16) lights up.

Three different speeds for the coarse feed are available: 400, 800 and 1200 µm/s. The three different speed settings are shown on the display (fig. 5.7) on the right side in the third line as follows:

- \* = 400 µm/s
- \*\* = 800 µm/s
- \*\*\* = 1200 µm/s

To select or change the speed, press button <speed coarse feed> (fig. 5.13) until the required speed is shown in the third line on the right side of the display (fig. 5.7).

**CAUTION!** With the function <coarse feed forwards> specimen and knife edge are adjusted very quickly. To avoid damage to specimen and knife, carefully observe this adjustment process.

Take note that the specimen and knife edge do not come in contact with each other. Carefully observe the narrowing gap between specimen and knife edge to stop the function <coarse feed forwards> in time before the specimen touches the knife edge.

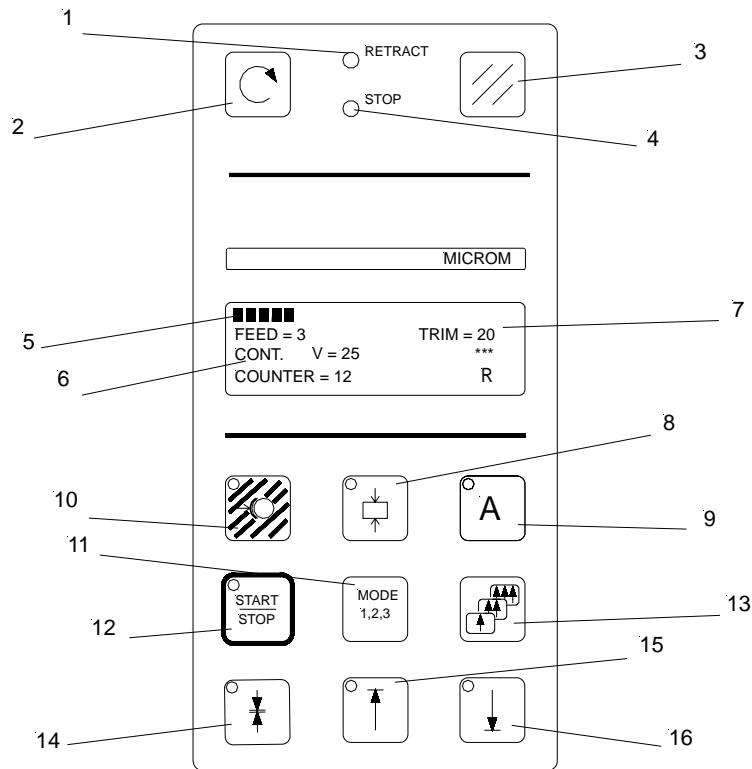

Fig. 5

### 2-5-2 TRIMMING AND FIRST CUTS

After the specimen and knife are adjusted, further gradual feed for trimming can be carried out using the function <trimming>. For different sectioning series, deeper layers of the specimen can be reached with the function <trimming>.

Button (fig. 5.14) is used for trimming, available as pulse or permanent function.

The <pulse function> is used when there is still some distance between specimen and knife edge. Press the button (fig. 5.14). Whenever the button (fig. 5.14) is pressed, the specimen holder moves forwards by the trimming value which was preselected on the control knob (fig. 4.3).

To select the <permanent function> press the control knob (fig. 4.3) to choose the trimming thickness setting. Then the red LED in button (fig. 5.14) lights up in addition. The feed is carried out at each cutting stroke in the upper reversal point. The <permanent function> is used to get faster to the desired sectioning level.

### 2-5-3 FINE FEED

After having adjusted specimen and knife as well as having trimmed the specimen, sectioning can be started. Press the control knob (fig. 4.3) to select the section thickness setting.

When the motor drive for the cutting movement is turned on, the specimen is sectioned with the desired section thickness.

## 2-6 MOTORIZED CUTTING DRIVE

The rotary microtome HM 350 S /HM 350 SV has a motorized cutting drive.

The cutting movement can be released by pressing the button START/STOP (fig. 5.12).

If the instrument is equipped with a foot pedal, the cutting movement can also be released by means of the foot pedal.

The controlled cutting speed can be set continuously from 10 - 400 mm/s on the control knob (fig. 4.4). The cutting speed refers to the cutting window. For the upward return travel a proportionally higher return speed is carried out. To adjust the cutting window in relation to a specimen, it can be set continuously within the maximum values.

**NOTE!** The motorized cutting drive can only be started, when the functions <cutting drive brake> (fig. 5.10) and <emergency stop> are not activated.

### 2-6-1 SETTING CUTTING WINDOW

Turn the turning knob so that the lower edge of the specimen is positioned slightly above the knife edge. Briefly press the button (fig. 5.8) to set the upper limit of the cutting window.

Continue turning the turning knob clockwise to place the upper edge of the specimen just below the knife edge. Briefly press the button (fig. 5.8) to set the lower limit of the cutting window. The green LED in button (fig. 5.8) shows the length of the cutting window during each further passing through of the cutting window zone. A cutting window should only be set while the specimen is moved downwards.

If, by mistake, a cutting window limit is set during return travel of the specimen, the set limits are applied to the cutting movement accordingly.

### 2-6-2 SELECTION OF OPERATING MODES

For the motorized cutting movement of the microtome, the following operating modes are available:

- interval stroke
- single stroke
- multi stroke
- continuous stroke

If the cutting drive is turned off, choose one of the above-mentioned operating modes by pressing the button MODE 1,2,3 (fig. 5.11) several times. The selected operating mode is shown on the display (fig. 5.7) on the operating panel. In the third line (fig. 5.6) on the left side of the display, the term INTER, SINGL, MUL xxx or CONT. is shown.

To start the cutting movement, press the button START/STOP (fig. 5.12) on the operating panel.

In case the instrument is equipped with a foot pedal, the cutting movement can also be released via the foot pedal.

During the motorized cutting movement, the green LED in button (fig. 5.12) lights up.

### INTERVAL STROKE

Press button (fig. 5.11) until the operating mode interval stroke (fig. 5.6) is shown on the display (fig. 5.7).

Now a gradual approach between specimen and cutting edge is possible. The cutting drive only moves as long as the button (fig. 5.12) is being pressed.

In case the instrument is equipped with a foot pedal, this process can also be controlled via the foot pedal.

## SINGLE STROKE

Press button (fig. 5.11) until the operating mode single stroke (fig. 5.6) is shown on the display (fig. 5.7).

Press the button (fig. 5.12) once to release a single cutting cycle. The movement stops in the upper reversal point.

In case the instrument is equipped with a foot pedal, this process can also be controlled via the foot pedal.

## MULTI STROKE

Press button (fig. 5.11) until the operating mode multi stroke (fig. 5.6) is shown on the display (fig. 5.7).

Press the button (fig. 5.12) once, to release a multiple cutting cycle. The number of the cutting strokes for one cutting cycle depends on the respective pre-selection. For this, the mode multi stroke must be selected as described above. Then keep the RESET button (fig. 5.3) pressed and then press simultaneously the mode button (fig. 5.11) until the desired cutting strokes (1 - 50) are shown on the display. The resolution is as follows:

1...10	1 $\mu\text{m}$ -increments
10...20	2 $\mu\text{m}$ -increments
20...30	5 $\mu\text{m}$ -increments
30...50	10 $\mu\text{m}$ -increments

The cutting movement stops in the upper reversal point.

In case the instrument is equipped with a foot pedal, this process can also be controlled via the foot pedal.

## CONTINUOUS STROKE

Press button (fig. 5.11) until the operating mode continuous stroke (fig. 5.6) is shown on the display (fig. 5.7).

To start a continuous cutting cycle, press the button (fig. 5.12) once. To stop the continuous stroke, press the button (fig. 5.12) once more. However, if a cutting cycle has been started, it will continue through and stop in the next upper reversal point.

In case the instrument is equipped with a foot pedal, this process can also be controlled via the foot pedal.

Optional equipment: foot pedal

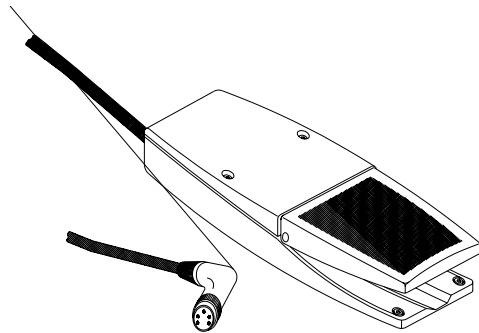

Fig. 6

## 2-6-3 SETTING CUTTING SPEED

The desired cutting speed is set continuously on the control knob (fig. 4.4) and shown in the middle of the third line on the display (fig. 5.7) with values from 0 - 99. To save time, the return travel speed is enhanced in relation to the cutting speed, especially for slow cutting speeds.

In addition, the maximum range of the cutting speed can be chosen smaller for fine sectioning than for trim sectioning. Switching over from trim sectioning to fine sectioning via knob (fig. 4.3) results in a reduction of the motorized cutting speed according to the corresponding preselection.

To preselect the speed reduction, press the buttons (fig. 5.3 and 5.8). The symbols for the speed >>>> are then shown in the third line on the display.

>>>>>>>>        = max. speed  
>                    = min. speed

To select the desired speed, press the scroll button (fig. 5.2).

To store the selected speed, press button (fig. 5.3).

**CAUTION!** Switching over from fine to trim sectioning results in the corresponding speed increase.

## 2-6-4 START AND STOP OF CUTTING DRIVE

The cutting drive can be turned on and off by means of the button (fig. 5.12). In case the instrument is equipped with a foot pedal, this process can be released via the foot pedal.

For this, the functions <cutting drive brake> and <emergency stop> must not be activated.

The course function of the cutting drive results from the selected cutting window, the selected operating mode and the set cutting speed.

## 2-6-5 CUTTING DRIVE BRAKE

The microtome is equipped with a cutting drive brake. This way, unintended movements of the specimen holder and knife carrier are avoided. This reduces the danger of being injured while adjusting specimen clamp and knife carrier.

**CAUTION!** When the instrument is turned off, the cutting drive brake cannot be activated.

First press button (fig. 5.12) to stop the motorized cutting movement. Then activate the function <cutting drive brake> by means of the button (fig. 5.10). The red LED in the button (fig. 5.10) lights up. Now, the motorized cutting drive cannot be started by mistake! To release the cutting drive brake, press button (fig. 5.10) once more.

**CAUTION!** For your personal safety, the <cutting drive brake> should be turned on when working on the specimen holder or knife carrier. For this press button (fig. 5.10).

## 2-6-6 EMERGENCY STOP

To quickly eliminate danger, the microtome has an <emergency stop>.

**CAUTION!** In case danger arises from cutting drive, push the <emergency stop>!

The emergency stop device is placed on the right upper side of the microtome.

Press this red button to stop immediately the motorized cutting drive. The red LED STOP (fig. 5.4) on the operating panel lights up, if the <emergency stop> is activated. Continue sectioning, pull out the red button. The cutting drive can be started again.

In case the instrument is equipped with a foot pedal, a second emergency stop device is integrated into the foot pedal. Vigorously step on the foot pedal to immediately stop the motorized cutting drive. This emergency stop device is activated as long as the foot pedal is being stepped on. During this time, the red LED STOP (fig. 5.4) on the operating panel lights up. Continue sectioning, release the foot pedal. The cutting drive can be started again.

## 2-7 INDICATION OF CUTTING PROCESSES

In the lower line of the display (fig. 5.7) information on the sectioning status can be seen. Press the <scroll button> (fig. 5.2), to show the various functions one after the other on the display. The following information on the present sectioning position of the instrument can alternatively be seen in the lower line of the display (fig. 5.7):

- number of sections
- sum of section thicknesses
- remaining travel to the front end position

For this, press button (fig. 5.2) until the required information lights up on the display (fig. 5.7). If no information is required in this line, press button (fig. 5.2) until this line of the display (fig. 5.7) is blank.

### 2-7-1 SECTION COUNTER

The section counter adds up the number of sections produced. After each downward movement of the specimen holder, the number on the section counter increases by 1. The counter can be reset to zero by means of the button (fig. 5.3).

### 2-7-2 SUM OF SECTION THICKNESSES

This value shows the sum in microns of the sections already cut. Trimming values as well as sectioning values are added up.

This value can also be reset to zero by means of the button (fig. 5.3).

### 2-7-3 REMAINING TRAVEL TO FRONT END POSITION

This value shows the distance in microns, which is left for sectioning.

If the specimen holder is in the rear end position, the display shows 28 000 µm. This number decreases the closer the specimen comes towards the front. If no further feed is possible anymore, the lower line of the display switches over automatically to the remaining travel indication, independently which information about the sectioning position was chosen before.

## 2-8 TURNING OFF THE FUNCTION <RETRACTION>

If desired, the function <retraction> can be turned off. This can be achieved by pressing the buttons (fig. 5.3 and 5.13) on condition that the lower line of the display (fig. 5.7) is blank.

The letter R (last line on the right side on the display) does not light up anymore.

The yellow LED RETRACTION, however, might still be on and goes off only after having passed from the return travel again to the cutting movement.

To turn on again the function <retraction>, press button (fig. 5.3) together with button (fig. 5.13), while the lower line on the display is blank.

## 2-9 SELECTING THE INDICATED LANGUAGE

The sectioning information on the display can be shown alternatively in three languages. English, German and French are available.

The instrument must be turned off. To select one of these languages, press buttons (fig. 5.2 and 5.3) simultaneously. Then turn on the power switch of the instrument with still pressed buttons (fig. 5.2 and 5.3). As the first suggestion LANGUAGE DEUTSCH lights up on the display (fig. 5.7). To select another language, press button (fig. 5.2) once or twice until the desired language is shown. To confirm the desired language, press the button (fig. 5.3) and turn off the instrument on the power switch. Wait a few seconds and then turn on the instrument again. The display (fig. 5.7) now shows the terms in the desired language.

If the originally desired language was skipped over by mistake, turn off the instrument and repeat above described process.

If the button (fig. 5.2) is pressed more than twice passing the language selection process, the user has entered the service-routine-program. This program can only be operated by trained service technicians. To quit this program, turn off the power switch of the instrument.

**2-10 SPECIMEN CLAMPING**

To clamp specimens, different specimen clamping systems are available.

**2-10-1 UNIVERSAL CASSETTE CLAMP**

The universal cassette clamp (fig. 7a/b) represents a quick change system.

Non-orienting version:

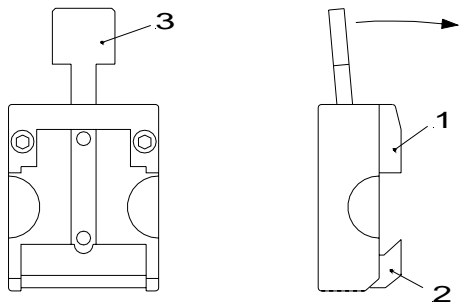

Fig. 7a

Orienting version:

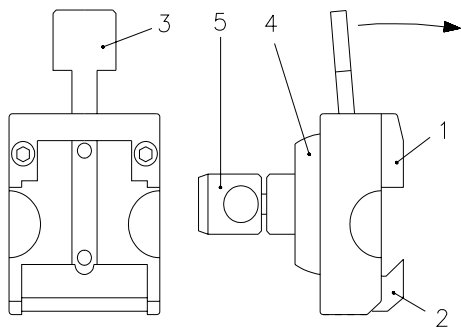

Fig. 7b

To insert or remove the cassette from between the fixed (fig. 7a/b.1) and movable (fig. 7a/b.2) jaws, pull the lever (fig. 7a/b.3) to the front.

**CAUTION!** To achieve an optimal clamping keep the locating surface of the cassette free of paraffin.

**2-10-2 STANDARD SPECIMEN CLAMP**

The standard specimen clamp (fig. 8) is used for rectangular and square paraffin and plastic blocks.

Non-orienting version:

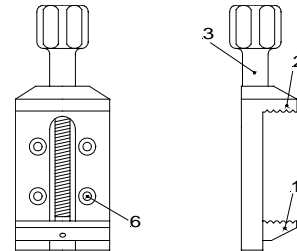

Fig. 8a

Orienting version:

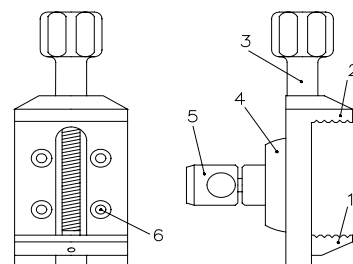

Fig. 8

Insert the specimen against the fixed jaw (fig. 8a/b.2) first. Then turn the knob (fig. 8a/b.3) to tighten the jaw (fig. 8a/b.1). Fig. 8b.4 and 8b.5 show the orienting adapter (see 2-11-2, adapter, orienting, with zero-orientation), fig. 8a/b.6 indicates the four holes for the fastening screws.

**NOTE!** For the stability of the specimen, do not let it project over the clamping jaws too much.

The standard specimen clamp is supplied with two movable jaws, which are different in weight. The lightweight jaw is used in addition with inserts for round specimens.

The heavier jaw is intended to be used together with the standard specimen clamp with no other holding elements.

To exchange the clamping jaw, unscrew the clamping screw (fig. 8a/b.3) to remove the jaw and replace it with the other one.

**2-10-3 INSERT FOR ROUND SPECIMENS, V-INSERT AND V-DISTANCE PIECE**

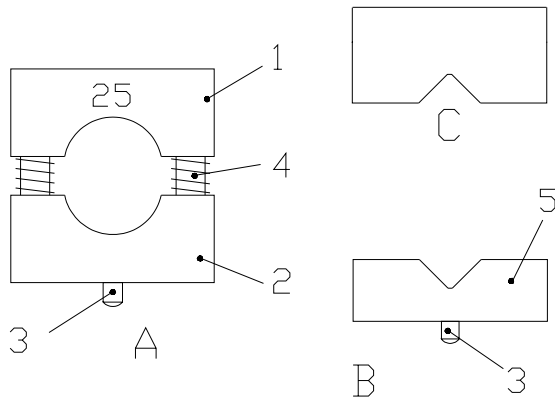

Fig. 9

To cut round specimens, the insert for round specimens (fig. 9 A) with defined diameters of 6, 15 and 25 mm (special sizes on request), the V-insert (fig. 9 B) or the V-distance piece (fig. 9 C) can be clamped into the standard specimen clamp. The pin (fig. 9.3), which fits into the lower clamping jaws (fig. 8a/b.1), positions the insert precisely. The two springs (fig. 9.4) make it easy to remove the specimen from the inserts (fig. 9.1 and 9.2).

To insert the V-distance piece (9 C) against the fixed jaw (fig. 8a/b.2) of the standard specimen clamp, first unscrew the knob from the spindle and pull the spindle out of the clamp. After having inserted the V-distance piece, put in the spindle and turn the knob (fig. 8a/b.3) on the spindle.

**2-10-4 FOIL CLAMP**

The foil clamp (fig. 10) is a clamping system for foils or thin specimens. To insert the specimen, loosen the three clamping screws (fig. 10.5) slightly and push the movable jaw (fig. 10.2) sideways against the two springs (fig. 10.3). The specimen is kept in place by the springs. For a new alignment its position can be changed. Turn the three clamping screws (fig. 10.5) to clamp the specimen tightly.

When using a non-orienting adapter, the foil clamp is installed directly on the adapter.

When using an orienting adapter with the instrument, first insert the enclosed graduated ring into the orienting adapter by means of the pin. With the graduated ring the orientation in X-/Y-direction is annulled. However, it is possible to turn in Z-axis 60° in either direction. Then mount the foil clamp.

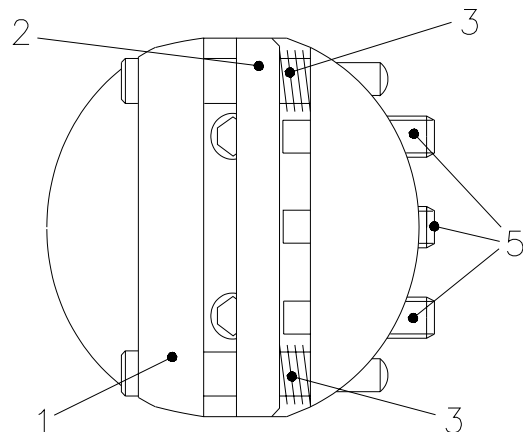

Fig. 10

Depending on the various specimens, it might be helpful to use in addition MICROM's sandwich supporting material (cat. no. 176010) on the right and left side between specimen and clamping jaw.

### 2-10-5 SEGMENT ARC AND UNIVERSAL SPECIMEN HOLDER

The segment arc and universal specimen holder are highly suitable for the clamping of small specimens embedded in plastic (fig. 11).

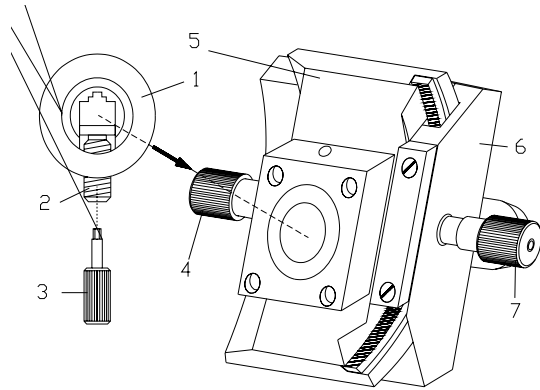

Fig. 11

The specimen is inserted in the holder (fig. 11.1) and clamped by means of the screw (fig. 11.2) with the hex head wrench (fig. 11.3). Then the holder together with the specimen is put into the segment carrier (fig. 11.5), where the holder can be turned 360°. Thus, the specimen can be aligned as required. Then, the holder is clamped by means of the screw (fig. 11.4) in the selected position. The carrier (fig. 11.5) can be moved on the base (fig. 11.6). In this way, the surface of the specimen can be oriented parallel to the knife. The knurled screw (fig. 11.7) is used to tighten the carrier (fig. 11.5) on the base (fig. 11.6).

## 2-11 ADAPTERS FOR SPECIMEN CLAMPING

### 2-11-1 NON-ORIENTING ADAPTATION

This adapter replaces the specimen holder and serves for the non-orienting fastening of the specimen clamps directly on the feed cylinder.

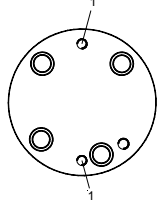

Fig. 12a

### 2-11-2 ADAPTER, ORIENTING, SPECIMEN HOLDER WITH ZERO-ORIENTATION

Using the orienting adapter (fig. 12b) fasten the specimen clamps on the feed cylinder. This allows the specimen to be aligned in relation to the knife.

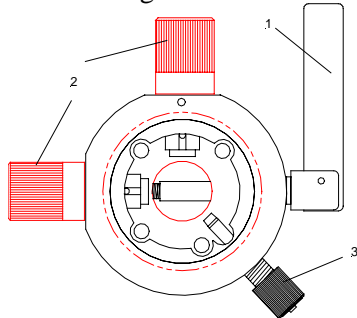

Fig. 12b

To bring the specimen into the desired position, turn the eccentric lever (fig. 12b.1) to the front. This will loosen the specimen clamp and a rotation of 360° on the cylinder axis (Z-axis) is possible. With the two adjusting screws (fig. 12b.2) the specimen clamp can be oriented by 8° in each direction on the X-axis and Y-axis.

Before starting cutting, press the eccentric lever (fig. 12b.1) upwards to fix the orientation of the specimen.

**NOTE!** When the adjusting knobs (fig. 12b.2) for specimen orientation are used, a slight lock-in position can be noticed during each rotation. The entire adjusting range includes two rotations in either direction. The middle lock-in position marks the zero position.

**NOTE!** To avoid undesirable movement while adjusting the specimen, press the eccentric lever (fig. 12b.1) upwards slightly. This will lightly hold the specimen clamp.

**CAUTION!** The spring bolt (fig. 12b.3) must always be tightened to keep the adjusting screws under constant tension.

### 2-11-3 CHANGING AND/OR CLAMPING SPECIMEN CLAMPS

The available specimen clamps are all clamped or removed in the same way.

#### Non-orienting version:

To insert a specimen clamp, fasten the corresponding specimen clamp via two screws on the non-orienting adapter (fig. 12a.1).

#### Orienting version:

To change a specimen clamp, press the eccentric lever (fig. 12b.1) downwards and pull it sideways in the direction of the arrow. Slightly unscrew the two adjusting screws (fig. 12b.2) as well as the spring bolt (fig. 12b.3).

Now the specimen clamp can be pulled out and can be replaced with another specimen clamping system.

Insert the new specimen clamp into the specimen holder so that the clamping lever can be put through the hole of the adapter (fig. 7b.5) from the right side all the way through. Tighten spring bolt (fig. 12b.3). Then align the specimen clamp by means of the orienting screws (fig. 12b.2). Then press the clamping lever (fig. 12b.1) upwards (see 2-11-4, readjusting specimen clamps).

### 2-11-4 READJUSTING SPECIMEN CLAMPS WITH ORIENTING ADAPTER

Frequent use of the clamping lever (fig. 12b.1) can lead to the fact that the specimen clamps cannot be clamped optimally anymore. If the necessary readjustments are not carried out, it might even be possible that the specimen clamp cannot be clamped anymore by means of the clamping lever (fig. 12b.1).

The clamping lever (fig. 12b.1) should be in an almost upright position. To determine the clamping position of the clamping lever, adjust the inner screw (fig. 13.1) on the rear side of the orienting adapter by means of an Allan key (size 3 mm).

Turn the Allan key in a clockwise direction if no clamping was achieved at all or if the clamping position of the clamping lever is too high.

If the clamping position of the clamping lever is too low, turn the Allan key in a counter-clockwise direction.

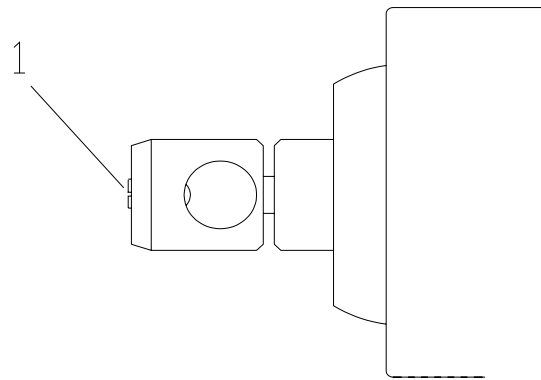

Fig. 13

Then insert the specimen clamp and check clamping position. If necessary, repeat above-described process.

## 2-12 KNIFE CARRIERS



### **Hazard of hand injuries:**

Due to moving parts in connection also with the microtome knife, a danger area arises, which might lead to hand injuries in case of non-compliance with the safety features of the microtome and when disregarding the instruction manual.

The knife carriers of the microtome are easy to use, can be moved sideways and are equipped with knife guards for user safety while adjusting knife and specimen.

The instruments can optionally be equipped with the disposable blade carrier ERF, which is solidly integrated on the microtome, or with a dovetail guide that is placed on the base plate.

This dovetail guide is designed universally so that the different knife carriers can be clamped and moved to the front and the back.

### **2-12-1 Solidly integrated DISPOSABLE BLADE CARRIER ERF**

#### **a) Inserting the blade**

The disposable blade carrier ERF is designed to take all commercially available high and low profile blades. Insert the blade into the slot behind the clamping plate (fig. 14.1). When using high profile blades, remove the spacer strip.

Turn the clamping lever (fig. 14.2) to the front. Swing the knife guard (fig. 14.3) to the front. Loosen the clamping lever (fig. 14.2) and, if necessary, slightly press the lower part of the clamping plate as well. A small gap between rail and clamping plate can be seen. Insert the blade on the rail and push it from the side to the middle. Afterwards, return the clamping lever (fig. 14.2) upright, thus locking the blade in position. Swing the knife guard (fig. 14.3) upwards.

For the full use of the blade, the entire upper part of the carrier (fig. 14.4) can be moved. For this loosen the lever (fig. 14.5).

This way, the entire cutting length of the blade can be used.

#### **b) Clearance angle**

The blade is fixed in its clearance angle to 10°.

#### **c) Protection against injury**

The knife guard (fig. 14.3) on the clamping plate can be moved upwards over the blade for the protection against injury.

#### **d) Moving the disposable blade carrier**

The disposable blade carrier ERF can be moved horizontally on the base plate by 10 mm. For this, loosen the four fillister head screws below the base plate and then fasten them again.

# Rotary Microtome HM 350 S / HM 350 SV

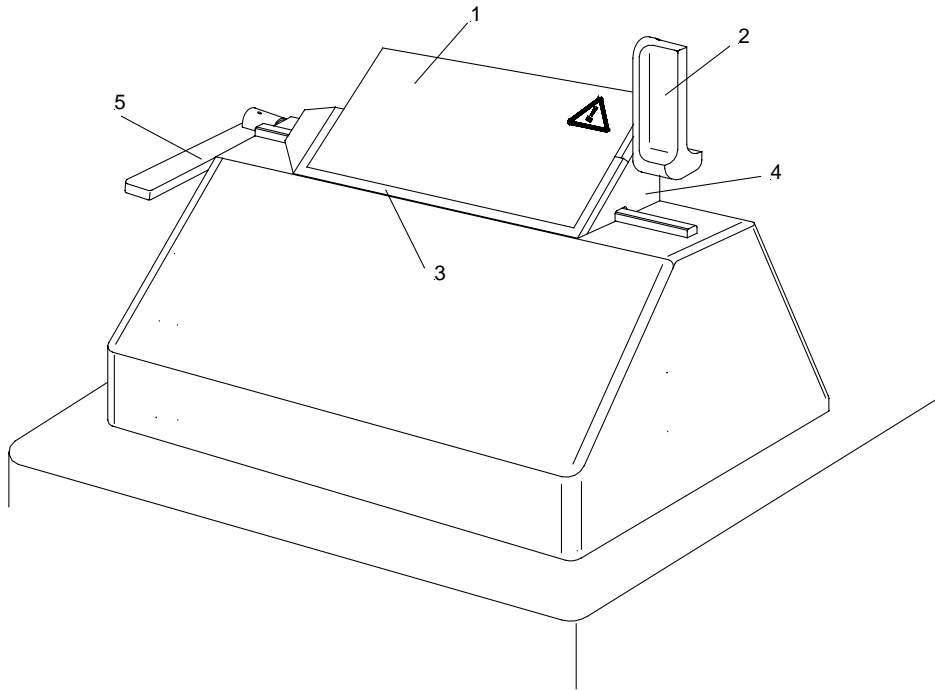

Fig. 14

## 2-12-2 DISPOSABLE BLADE CARRIER E

### a) Inserting the blade

The disposable blade carrier E is designed to take all commercially available high and low profile blades. Insert the blade into the slot behind the clamping plate (fig. 15.5). When using high profile blades, first loosen the two screws (fig. 15.9) and remove the spacer strip (fig. 15.3).

Turn the clamping lever (fig. 15.7) to the front. Swing the bracket with scale (fig. 15.4) to the front. Loosen the clamping lever (fig. 15.7) and, if necessary, slightly press the lower part of the clamping plate as well. A small gap between rail (fig. 15.3) and clamping plate (fig. 15.5) can be seen. Insert the blade on the rail (fig. 15.3) and push it from the side to the middle. Afterwards, return the clamping lever (fig. 15.7) upright, thus locking the blade in position.

The bracket (fig. 15.4) is provided with a scale. After loosening the clamping lever (fig. 15.7) and after having moved the bracket (fig. 15.4) upwards, move the blade together with clamping plate (fig. 15.5) according to the scale by means of the knife guard to the left or right side. This way, the entire cutting length of the blade can be used. Then press the clamping lever (fig. 15.7) upwards.

### b) Adjusting clearance angle

The clearance angle between cutting edge and specimen can be shifted and adjusted to the requirements of the tissue to be sectioned. Loosen the clamping lever (fig. 15.8) on the right side of the knife carrier and move the upper part of the knife carrier (fig. 15.2) on the base (fig. 15.1). The adjusted clearance angle can be read on the scale. Then turn the clamping lever (fig. 15.8) upwards to lock in the new clearance angle.

**NOTE!** By experience, usable cuts are only achieved at a clearance angle of 10° or more.

If the clamping lever (fig. 15.8) is loosened, the upper part of the knife carrier can be moved 1 cm to the left or right side. This way, the cutting edge can optimally be used.

### c) Moving the knife carrier on the dovetail guide

Loosen the clamping lever (fig. 15.6) on the left side of the knife carrier, to move the carrier forwards or backwards on the dovetail guide. This allows a rough adjustment of the knife to the specimen.

### d) Protection against injury

A bracket (fig. 15.4) on the clamping plate can be moved upwards over the blade for the protection against injury.

# Rotary Microtome HM 350 S / HM 350 SV

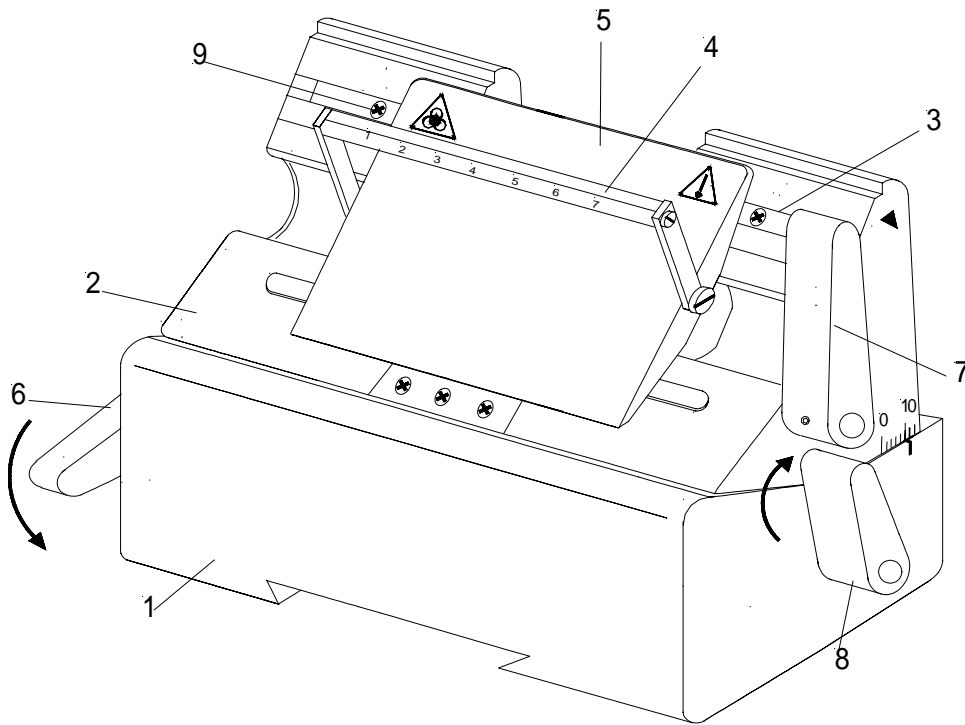

Fig. 15

## 2-12-3 DISPOSABLE BLADE CARRIER ER

### a) Inserting the blade

The disposable blade carrier ER is designed to take all commercially available high and low profile blades. Insert the blade into the slot behind the clamping plate (fig. 16.1). When using high profile blades, remove the spacer strip.

Turn the clamping lever (fig. 16.2) to the front. Swing the knife guard (fig. 16.4) downwards. Loosen the clamping lever (fig. 16.2) and, if necessary, slightly press the lower part of the clamping plate as well. A small gap between rail and clamping plate can be seen. Insert the blade on the rail and push it from the side to the middle. Afterwards, return the clamping lever (fig. 16.2) upright, thus locking the blade in position.

For the full use of the blade, the entire upper part of the carrier (fig. 16.4) can be moved. For this loosen the lever (fig. 16.5).

This way, the entire cutting length of the blade can be used.

### b) Adjusting clearance angle

The clearance angle between cutting edge and specimen can be shifted and adjusted to the requirements of the tissue to be sectioned.

Loosen the clamping lever (fig. 16.6) on the right side of the knife carrier and move the upper part of the knife carrier (fig. 16.7) on the base (fig. 16.8). The adjusted clearance angle can be read on the scale. Then turn the clamping lever (fig. 16.6) upwards to lock in the new clearance angle.

If the clamping lever (fig. 16.6) is loosened, the upper part of the knife carrier can be moved 1 cm to the left or right side. This way, the cutting edge can optimally be used.

<b>NOTE!</b> By experience, usable cuts are only achieved at a clearance angle of 10° or more.
--

### c) Moving the knife carrier on the dovetail guide

To move or fix the knife carrier on the dovetail guide, loosen the lever (fig. 16.9), which is placed on the left side on the base plate of the microtome. This allows a rough adjustment of the knife to the specimen.

### d) Protection against injury

The knife carrier is equipped with a knife guard (fig. 16.3), which should be placed over the blade. This reduces the danger of injury considerably!

# Rotary Microtome HM 350 S / HM 350 SV

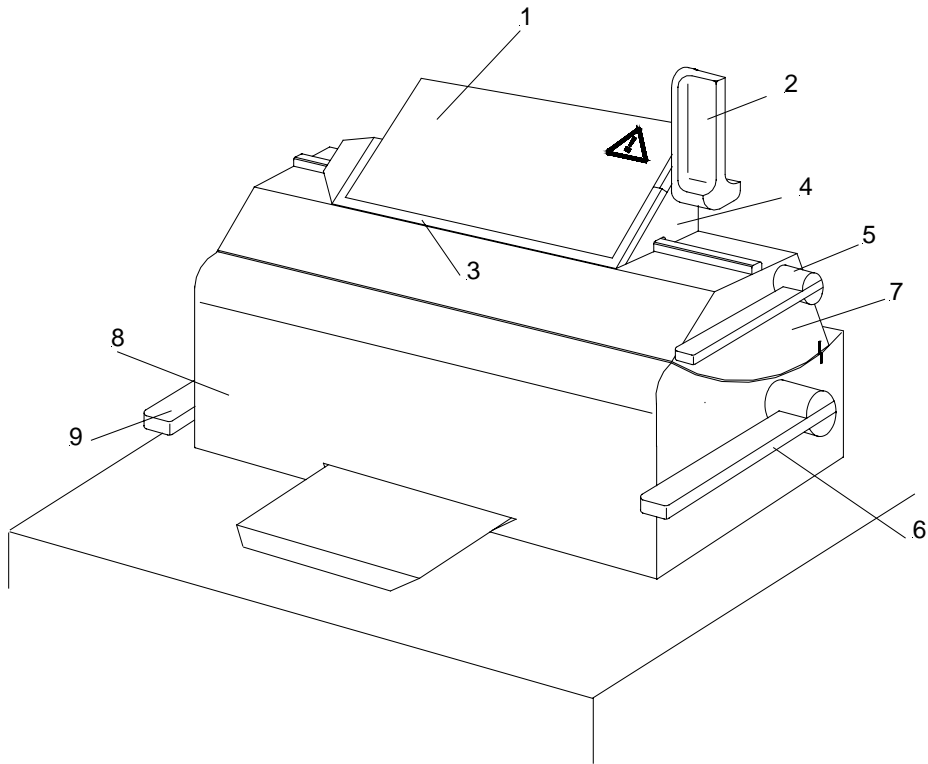

Fig. 16

## 2-12-4 STANDARD KNIFE CARRIER N

### a) Inserting the knife

To insert the knife, unscrew the two clamping screws (fig. 17.9) slightly until the knife can be pushed in from the side. The height of the knife is adjusted by the two knurled nuts (fig. 17.6) and the bar (fig. 17.7). If a cutting area of the knife is no longer usable, the knife can be moved approx. 2-3 cm to the left or right side by loosening the clamping screws (fig. 17.9).

### b) Adjusting clearance angle

The clearance angle between cutting edge and specimen can be shifted and adjusted to the requirements of the tissue to be sectioned. Loosen the clamping lever (fig. 17.4) on the right side of the knife carrier and move the upper part of the knife carrier (fig. 17.2) on the knife carrier base (fig. 17.1). The adjusted clearance angle can be read on the scale. Then turn the clamping lever (fig. 17.4) upwards to lock in the new clearance angle.

<b>NOTE!</b> By experience, usable cuts are only achieved at a clearance angle of 10° or more.
--

If the clamping lever (fig. 17.4) is loosened, the upper part of the knife carrier can be moved 1 cm to the left or right side. This way, the cutting edge can optimally be used.

### c) Moving the knife carrier on the dovetail guide

Loosen the clamping lever (fig. 17.5) on the left side of the knife carrier to move the carrier forwards or backwards on the dovetail guide. This allows a rough adjustment of the knife to the specimen.

### d) Protection against injury

The knife carrier is equipped with two knife guards (fig. 17.8) that can be moved sideways. They should be pushed together to the middle while the knife and specimen are adjusted. In this way, the danger of injury from the knife can considerably be diminished.

# Rotary Microtome HM 350 S / HM 350 SV

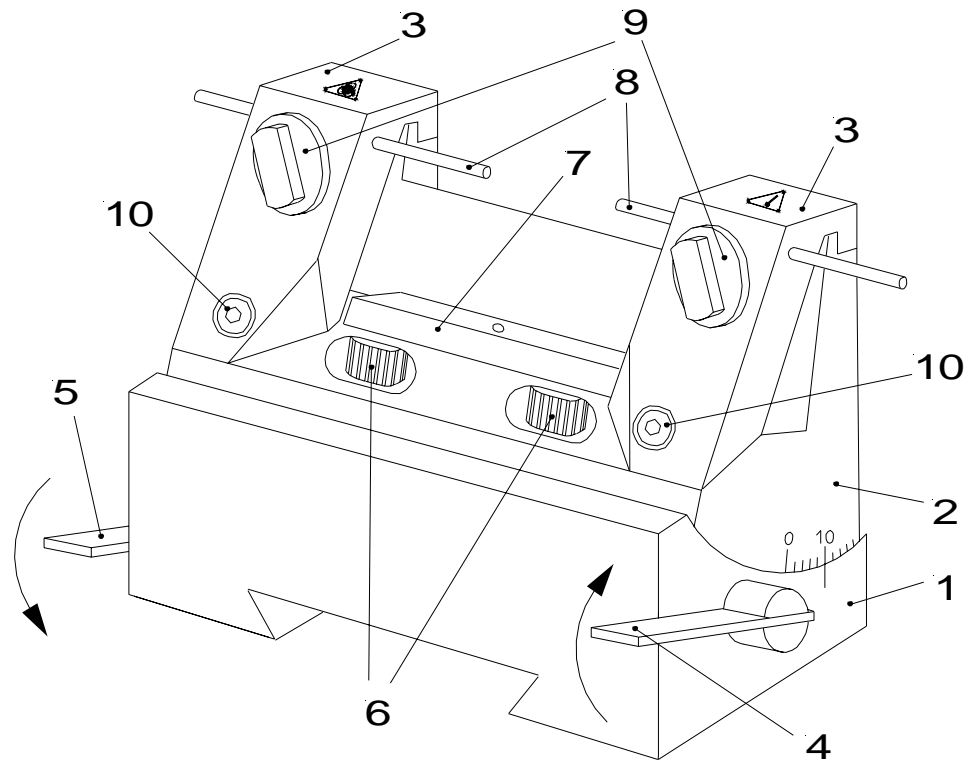

Fig. 17

### 2-12-3 KNIFE CARRIER C

#### a) Inserting the knife

To insert the knife, the clamping screws (fig. 18.10) must be unscrewed slightly so the knife can be pushed in from the side. The height of the knife is adjusted with the two knurled nuts (fig. 18.6) and the bar (fig. 18.7). If the cutting zone of the knife cannot be used anymore, it can be moved over its entire length to the left and right side by loosening the clamping screws. This allows an optimal use of the entire knife edge.

**CAUTION!** When clamping the knife, please tighten the two clamping screws (fig. 18.10) simultaneously.

#### b) Adjusting clearance angle

The clearance angle between cutting edge and specimen can be shifted and adjusted to the requirements of the tissue to be sectioned. Loosen the clamping lever (fig. 18.4) on the right side of the knife carrier and move the upper part of the knife carrier (fig. 18.2) on the base (fig. 18.1). The adjusted clearance angle can be read on the side scale. Then turn the clamping lever (fig. 18.4) upwards to lock in the new clearance angle.

**NOTE!** By experience, usable cuts are only achieved at a clearance angle of 10° or more.

If the clamping lever (fig. 18.4) is loosened, the upper part of the knife carrier can be moved 1 cm to the left or right side. This way, the cutting edge can optimally be used.

#### c) Moving the knife carrier on the dovetail guide

Loosen the clamping lever (fig. 18.5) on the left side of the knife carrier to move the carrier forwards and backwards on the dovetail guide. This allows a rough adjustment of knife and specimen.

#### d) Protection against injury

The knife carrier is equipped with two knife guards (fig. 18.9) which can be moved sideways. These knife guards should be pushed together in the middle while adjusting knife or specimen. This reduces the danger of injury considerably.

#### e) Central clamping plate

The knife is clamped and stabilized in the cutting zone by the central clamping plate (fig. 18.8.1, 18.8.2) - exactly where the highest cutting forces are applied.

**NOTE!** Two types of clamping plates are available for the knives:

clamping plate c for c-knives,  
clamping plate d for d-knives.

Rotary Microtome HM 350 S / HM 350 SV

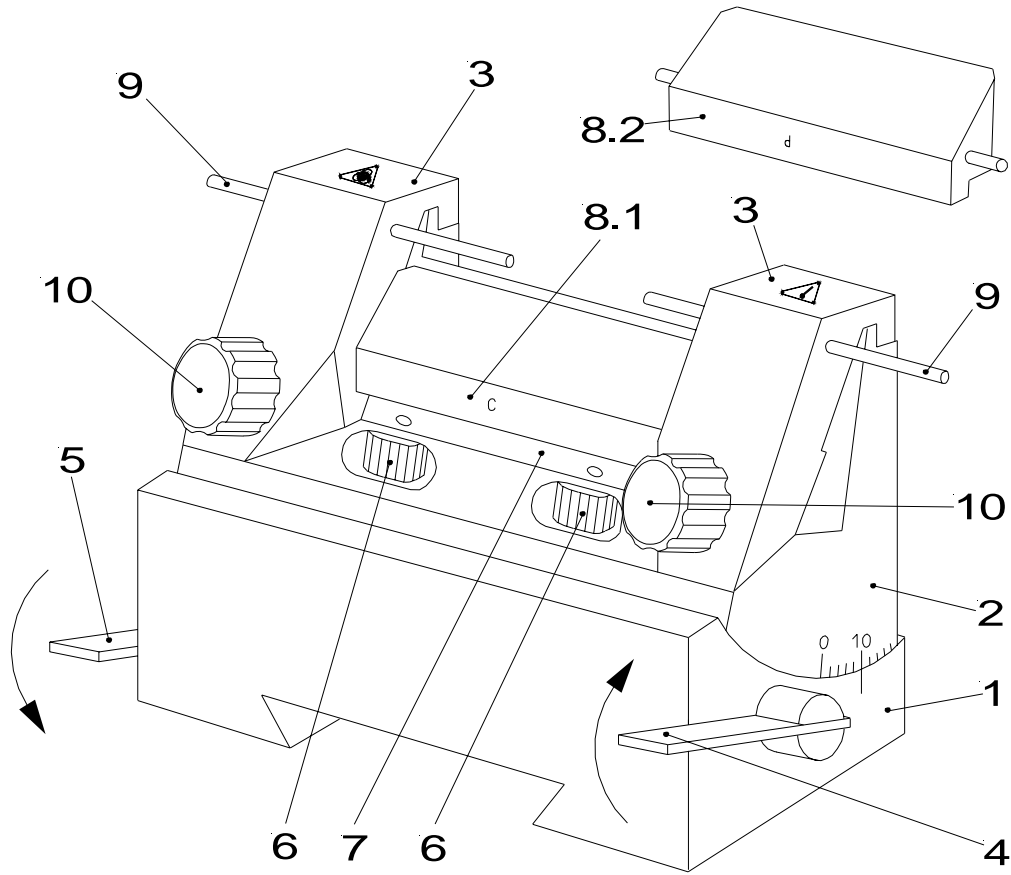

Fig. 18

Fig. 19 shows schematically the angles on the cutting edge profiles of c- and d-knives.

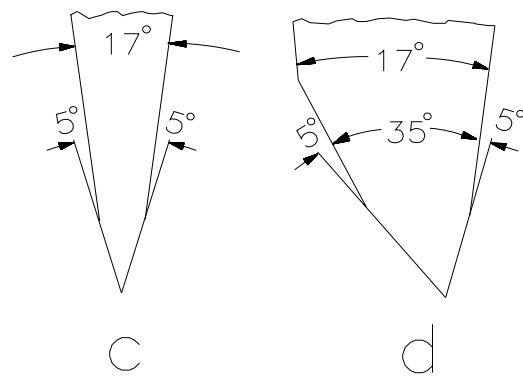

Fig. 19

## 2-12-6 KNIFE CARRIER S

### a) Inserting the knife

The knife carrier S is designed to take triangular glass knives, diamond and sapphire knives. These knives are put into the knife insert (fig. 20.8) and clamped with the clamping screw (fig. 20.9). The black arrows in fig. 20 show the clamping direction of the various clamping devices.

### b) Adjusting clearance angle

The clearance angle adjustment of the knife can be set by moving the insert (fig. 20.8) on the upper part (fig. 20.5). Turn the clamping lever (fig. 20.10) downwards to lock in the selected clearance angle.

### c) Moving the knife sideways

Move the knife carrier together with the upper part (fig. 20.5) sideways.

Thus, the desired position concerning the specimen can be adjusted. Loosen the knurled screw (fig. 20.7) slightly. Turn one of the two set screws (fig. 20.6) to achieve the desired side movement of the upper part (fig. 20.5) with regard to the carrier (fig. 20.3). Tighten the knurled screw (fig. 20.7) slightly after this positioning.

**CAUTION!** If the knurled screw (fig. 20.7) is tightened, do not adjust the set screws (fig. 20.6)

### d) Turning the carrier

Loosen the clamping screw (fig. 20.4) to move the carrier to the left or right side on the socket up to approx. 30° according to the bowed orientation scale. Afterwards, tighten the clamping screw (fig. 20.4) again.

### e) Moving the knife carrier on the dovetail guide

Swing the clamping lever (fig. 20.2) to the back to release the knife carrier. The knife carrier can then be moved forwards or backwards.

# Rotary Microtome HM 350 S / HM 350 SV

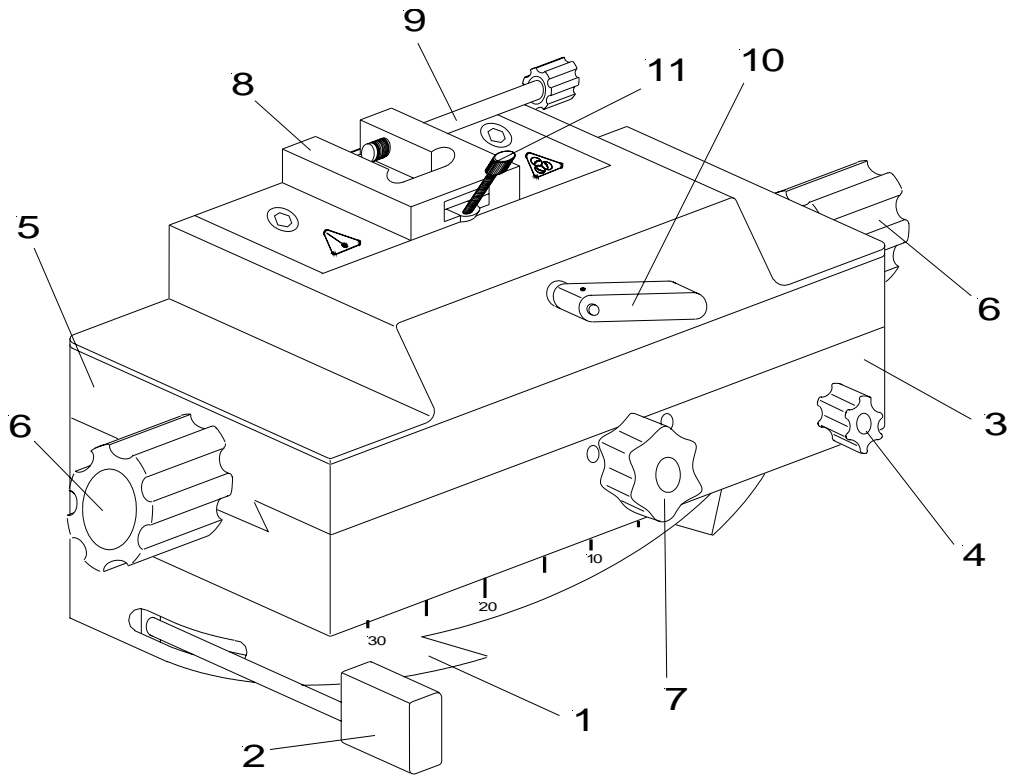

Fig. 20

**2-12-7 READJUSTING KNIFE CARRIERS E, ER, N AND C (REMOVABLE VERSIONS)**

Frequent use of the clamping levers can lead to the fact that the knife carriers cannot be clamped optimally anymore. If the necessary readjustments are not carried out, it might even be possible that the knife carriers cannot be clamped anymore.

If possible, the clamping lever should be in a 45°-position towards the front (fig. 21).

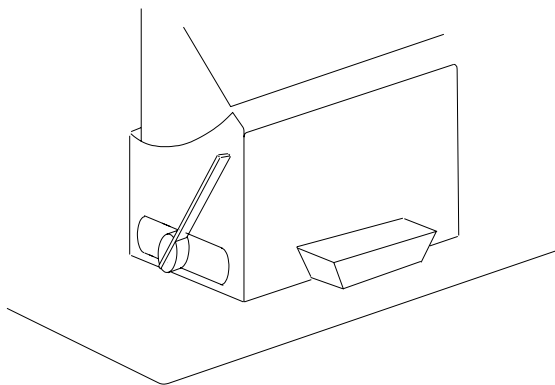

Fig. 21

If the clamping lever is in an unfavourable clamping position, i.e. not in a 45°-position, remove knife carrier. Loosen the set screw (fig. 22.1) on the bottom of the knife carrier. Insert a pin into one of the holes (fig. 22.2) that can be seen in the brass screw and turn the brass screw.

If the clamping position of the lever should be moved towards the front, turn the brass screw (fig. 22.2) in a clockwise direction. If the clamping position of the lever should be moved towards the back, turn the brass screw (fig. 22.2) in a counter-clockwise direction. Before putting on the knife carrier again, tighten set screw (fig. 22.1).

Then put the knife carrier on the dovetail guide and check the clamping position of the clamping lever. If necessary, repeat above-mentioned process.

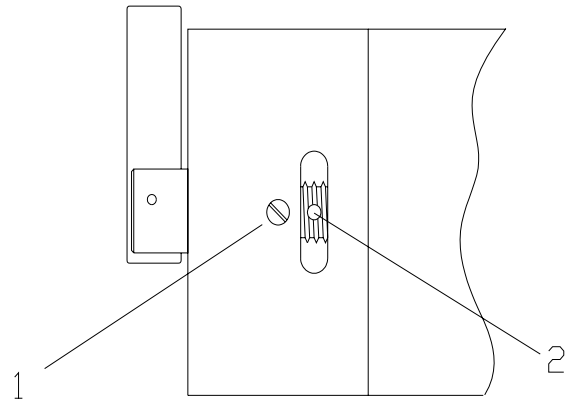

Fig. 22

**2-12-6 READJUSTING KNIFE CARRIER S (REMOVABLE VERSION)**

Readjusting the clamping lever (fig. 20.2) of the knife carrier S can also become necessary.

If the clamping lever is in an unfavourable position, i.e. not in a 45°-position, remove the knife carrier. Loosen or tighten the set screw on the bottom of the knife carrier to change the clamping position of the lever.

If the clamping position of the lever should be moved towards the front, turn the set screw in a clockwise direction. If the clamping position of the lever should be moved towards the back, turn the set screw counter-clockwise.

Then slide the knife carrier on the dovetail guide and check the clamping position of the lever. If necessary, repeat above-mentioned process.

## 2-13 STORAGE UNIT

The storage unit, which can be cooled, can be installed on the left side of the instrument instead of the operating panel. It can also be used freestanding as a separate unit. For this, insert the attached support on the rear bottom of the storage unit.

The four tubes (fig. 23.1), which are placed in the rear part of the storage unit, can be used for storing brushes, tweezers and other working instruments. The tubes can be removed for cleaning.

Before using the insert (fig. 23.2) for cooling cassettes, put it into the deep freezer.

This way, specimens can be kept cool for a certain time.

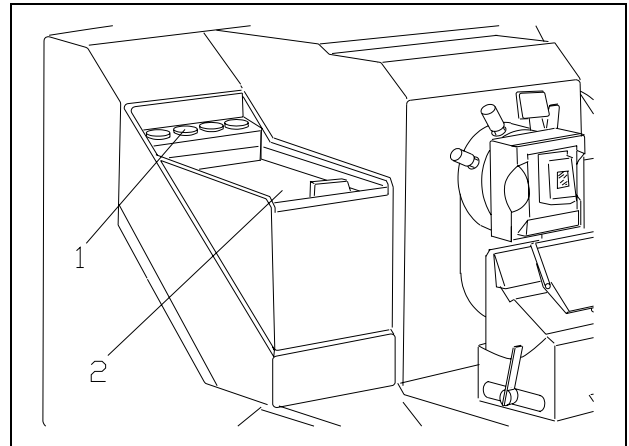

Fig. 23

## 2-14 MEMORY FUNCTION

The memory function is used to quickly find again the same position for the first cuts.

This function can only be used on condition that blocks, which have been embedded in the same molds, are cut. The blocks must have almost the same height.

To set the so-called "first-cut-position", move the specimen clamping via coarse feed function forwards until the specimen is almost situated at the knife edge.

To store this position, first press the reset button (fig. 5.3). Then also press the button A (fig. 5.9) while the reset button (fig. 5.3) is still being pressed.

Then continue routine sectioning (trimming, first cuts, fine sectioning). After having finished sectioning of the block, press button (fig. 5.9) so that the specimen clamping moves backwards. Then unclamp the specimen.

To have more space between knife edge and specimen when changing the specimen, a safety distance (from 0 - 7 mm) can be selected besides the selection for the first-cut-position.

For this, turn off the instrument. Then press button A (fig. 5.9) and turn on the power switch of the instrument with still pressed button A (fig. 5.9).

The user has now entered a menu for selecting the safety distance.

Press the scroll button (fig. 5.2) until the desired value is selected. To acknowledge the safety distance, press the reset button (fig. 5.3).

When the first-cut-position as well as the safety distance have been stored, please proceed as follows:

Clamp the specimen and press the button A (fig. 5.9) once. First, the specimen clamping moves to the upper reversal point. Then the specimen clamping moves towards the knife carrier to the first cut position. Afterwards, continue with routine sectioning.

After having finished sectioning of the block, press button A (fig. 5.9) once more. Now the specimen clamping moves backwards to the first-cut-position plus the selected safety distance.

After having inserted a new block and having pressed the button A (fig. 5.9), the specimen clamping moves forwards to the first-cut-position.

**CAUTION!** The stored cutting position can only be used effectively when blocks with the same height are cut. Neither adjustments on the knife carrier must be made nor must the knife carrier be moved on the dovetail guide.

**DANGER!** When moving the knife carrier on the dovetail guide, a new first-cut-position must be selected as otherwise the danger of a collision with injuries might arise.

When turning on the instrument later again, the first-cut-position must be defined and stored again for safety reasons.

## 2-15 EQUIPMENT VERSIONS

**The rotary microtome HM 350 S can be supplied with the following accessories:**

1 adapter, non-orienting

**or**

1 adapter with zero-orientation

1 solidly integrated disposable blade carrier ERF

**or**

1 dovetail guide without knife carrier

(Knife carrier must be ordered separately)

1 foot pedal

**The rotary microtome HM 350 SV can be supplied with the following accessories:**

1 adapter, non-orienting

**or**

1 adapter with zero-orientation

1 solidly integrated disposable blade carrier ERF

**or**

1 dovetail guide without knife carrier

(Knife carrier must be ordered separately)

1 foot pedal

**All instrument versions include the following standard equipment:**

1 Hex head wrench 6 mm

1 Interlock plug

1 Cover

1 Para Gard, 100 ml

1 Instruction manual

**2-16 ADDITIONAL EQUIPMENT  
(OPTIONAL)**

**2-16-1 KNIFE CARRIERS**

**Cat. no.**

Standard knife carrier N	705010
Standard knife carrier N for Ralph insert	705400
Standard knife carrier SN	705060
Insert for Ralph knife for standard knife carrier N	565310
Disposable blade carrier E	705050
Disposable blade carrier ER	705100
Disposable blade carrier ERF (integrated)	705110
Knife carrier C	705040
Knife carrier SL	705350
Knife carrier S	705070
Insert for Ralph knife for knife carrier S	565320

**2-16-2 SPECIMEN CLAMPS**

Standard specimen clamp	715010
Universal cassette clamp	715020
Foil clamp	715030
Sandwich supporting material	176010

## Rotary Microtome HM 350 S / HM 350 SV

Insert for round specimens, ø 6 mm	715070
Insert for round specimens, ø 15 mm	715080
Insert for round specimens, ø 19 mm	715280
Insert for round specimens, ø 25 mm	715090
V-Insert	715100
V-distance piece	715320
Segment arc	715050
Universal specimen holder	715060
Backlighting system	630130

### 2-16-3 MICROTOME KNIVES

Conventional knives type c	
12 cm	152010
16 cm	152020
18,5 cm	152270
22 cm	152030
Conventional knives type d	
12 cm	152060
16 cm	152070
22 cm	152080
Tungsten carbide knife, 16 cm, d	152120
Knife cases	
12 cm	152220
16 cm	152230
18,5 cm	152280
22 cm	152240
Disposable blades for paraffin	
S 35, 50 pieces in dispenser	152170
R 35, 50 pieces in dispenser	152370
Superlap blades, 10 pieces	152190

## Rotary Microtome HM 350 S / HM 350 SV

### 2-16-4 ADDITIONAL ACCESSORIES

Fast freezing unit K 300	
100 V, 50 - 60 Hz	770080
115 V, 60 Hz	770070
230 V, 50 Hz	770030
240 V, 50 Hz	770090
Section transfer system STS	
100 V, 50 - 60 Hz	771030
115 V, 60 Hz	771020
230 V, 50 Hz	771010
240 V, 50 Hz	771040
Storage unit	520450
Lubricating oil, 100 ml	350110
Lubricating oil, 250 ml	350120
Paraffin repellent, PARA GARD, 100 ml	350170

## **PART 3 THEORY OF OPERATION**

### **3-1 CUTTING MOVEMENT AND RETRACTION**

During trimming or for the first cuts, the manual rotary movement of the turning knobs results in the vertical movement of the specimen clamp. After having finished the first cuts, fine sectioning can be started. For this, the motorized cutting drive is used.

Sectioning is carried out by knives or blades, which must be adjusted and fixed on the knife carrier.

With the downward movement of the specimen, sectioning is carried out (cutting movement).

After having passed the lower reversal point, the upward return travel of the specimen is carried out. During this return travel, the specimen is drawn back automatically to protect knife and specimen. If required, the function <retraction> can be turned off.

The selected section thickness is delivered at the upper reversal point of the return travel.

The number of the sections made can be shown on the section counter on the display. After each downward movement of the specimen holder, the number on the section counter increases by 1. The sum of the sections carried out can also be seen on the display. For this, trimming values and sectioning values are added up. Section counter and sum of section thicknesses can be reset to zero at any time by means of the RESET-button.

Moreover, the remaining travel to the front end position can also be shown on the display. The remaining travel, which is still available for sectioning, is shown in microns. If the specimen holder is in the back end position, the display shows 28 000 µm. This number decreases, the further the specimen holder is moved towards the front. (See 2-7, indication of cutting processes).

### **3-2 SPECIMEN COARSE FEED AND TRIMMING FUNCTION**

After changing the specimen or moving the knife or knife carrier, it is necessary to adjust the specimen to the knife edge again. This can easily be done by means of the specimen coarse feed and the defined trimming values. After the specimen and the knife are adjusted, further gradual feed for trimming can be carried out by pressing the button for trimming, which is available as pulse or permanent function. If the <pulse function> is chosen, the specimen holder moves forwards by the pre-selected trimming value whenever pressing the button for trimming. If the <permanent function> is chosen, the feed is carried out in the upper reversal point at each handwheel rotation.

### **3-3 OPERATING PANEL AND FOOT PEDAL**

The operating controls of the panel are well arranged for safe and easy use. The operating panel is optionally solidly integrated on the instrument or removable so that it can be used as a separate unit. In addition, the cutting movement can be started and stopped by means of the foot pedal, if the instrument is equipped with a foot pedal.

### **3-4 SPECIMEN CLAMPING SYSTEM AND SPECIMEN ORIENTATION**

According to the form and size of the specimens, different specimen clamping systems are available to carry the specimen.

In connection with the non-orienting adapter, a direct adaptation on the instrument is possible.

It is very easy to align the specimen to the knife, using the orienting adapter with zero orientation.

### **3-5 KNIFE CARRIERS**

The knife carriers are easy to use. They allow the microtome knives to be clamped and adjusted as needed. Depending on application, special knife carriers are available.

### **3-6 MICROTOME WITH FREEZING UNIT**

The freezing unit K 300 allows frozen sectioning with the specimen temperature as low as  $-45^{\circ}\text{C}$ .

## PART 4 WORKING WITH THE MICROTOME

### 4-1 PREPARATION AND ORIENTATION

Before sectioning, the specimens must be prepared appropriately and embedded in suitable media. The universal cassette as well as different forms for round or rectangular specimens can be used for the embedding.

With the non-orienting adapter, the specimen clamp can directly be fixed on the instrument (see 2-11-1, adapter, non-orienting).

With the orienting adapter with zero orientation and cylinder head, the specimen can easily be oriented to the knife (see 2-11-2, adapter, orienting with zero orientation).

### 4-2 COARSE FEED AND TRIMMING FUNCTION

The knife carrier can be moved and the coarse feed or the trimming function can be used to adjust approximately the space between specimen and knife edge.

Turning the turning knobs in a clockwise direction results in the first contact between knife and specimen. Continue this to start trimming the specimen thus achieving the desired level. Any waste should be wiped away in an upward direction with a brush.

### 4-3 SECTIONING INSTRUCTIONS



#### **Hazard of hand injuries:**

Due to moving parts in connection also with the microtome knife, a danger area arises, which might lead to hand injuries in case of non-compliance with the safety features of the microtome and when disregarding the instruction manual.

To cut usable sections, the following points are of utmost importance:

#### 4-3-1 CONDITION OF THE KNIFE EDGE

Only use a sharp knife! If the knife edge is blunt, move the knife horizontally either to the right or left side to continue working with the sharp area of the cutting edge, or have the knife resharpened.

#### 4-3-2 CLEAN KNIFE SURFACES

For optimal sectioning, the front and back of the knife must be cleaned of paraffin waste.

## 4-4 HOW TO AVOID MALFUNCTIONS

### 4-4-1 PREPARATION OF THE SPECIMEN

When preparing specimens, be sure that a suitable embedding medium, fixation, dehydration and infiltration time are chosen.

### 4-4-2 TEMPERATURE OF THE SPECIMEN

Sectioning is carried out at ambient temperature (excluding frozen sections). If the temperature is too high, the paraffin softens. Therefore, avoid heating paraffin specimens by direct exposure to sunlight or other sources of heat.

### 4-4-3 TIGHTENING THE CLAMPING SCREWS

Tighten all clamping screws and clamping levers on the knife carrier as well as specimen holder and specimen orientation.

### 4-4-4 SELECTION OF THE KNIFE

Carefully select the required knife material and profile.

### 4-4-5 ADJUSTMENT OF THE KNIFE

Select a clearance angle adjustment of 5 - 15° according to the facet angle. When using the integrated disposable blade carrier ERF, the clearance angle is set to 10°.

Take care to adjust the proper clearance angle of the knife: 5 - 7° for glass knives. For diamond knives ask the knife manufacturer.

Take care to adjust knife height.

### 4-4-6 CUTTING SPEED

Take care to select proper cutting speed.

General Rule: The harder the material, the slower the cutting speed!!

### 4-4-7 TRIMMING

Take care in bringing knife and specimen together.

**PART 5 MAINTENANCE**

**Annual routine maintenance**

To secure section quality and functioning of the microtome, it is recommended that a routine maintenance be performed by a trained service technician once a year.

**Service contract**

MICROM offers a service contract which guarantees that your instrument is always in perfect condition. For more information, please contact the nearest MICROM sales office.

**Exchange of fuses**

The two mains fuses (fig. 24.3) are installed on the rear side of the instrument beside the power switch (fig. 24.1).

To exchange the two fuses, turn off the power switch of the instrument and unplug the instrument. Open the fuse holder (fig. 24.2) from the left side by means of a flat screw driver. Pull the fuses off the fuse holder and replace the fuses with new ones.

**Rating of fuses:**

For power requirements: 220-240 V:

- 2 fuses T 1,6 AH (cat. no. 326670)

For power requirements: 100-120 V:

- 2 fuses T 3,2 AH (cat. no. 326660)

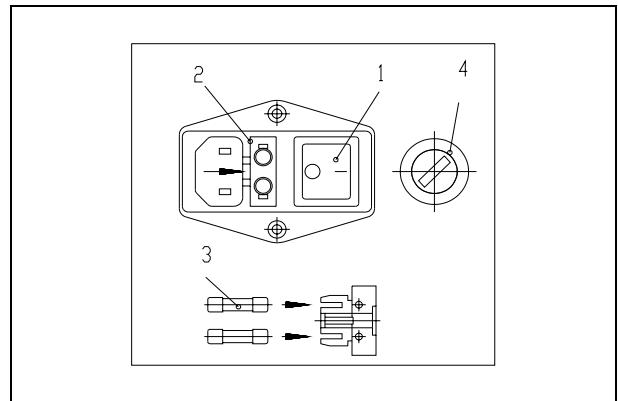

Fig. 24

**Exchange of fuse for the motor supply**

The fuse for the motor supply (fig. 24.4) is placed on the rear side of the instrument on the right side of the mains plug unit and secures the supply voltage of the cutting drive.

To exchange the two fuses, turn off the power switch of the instrument and unplug the instrument.

Press the fuse holder cap by means of a screwdriver and turn it to the right side.

Remove the fuse and replace it with a new one. Insert the cap with the fuse into the fuse holder and lock the bajonet catch.

**Rating of fuse:**

- 1 fuse T 2,5 AH (cat. no. 326500)

## PART 6 CLEANING AND CARE

### 6-1 CLEANING

#### Cleaning intervals

Cleaning of the microtome depends on how frequently the microtome is used. The more it is used, the more it will need to be cleaned.

#### Cleaning agents

Mild household cleaners can be used to clean the microtome. Do not use aggressive cleaners or solvents, as the paint and plastic parts can be affected.

**NOTE!** Before starting sectioning, instrument, knife carrier and section waste tray should be treated with a commercially available paraffin repellent. (See 2-16-5, additional accessories).

**CAUTION!** When getting in contact with cleaning agents or paraffin repellents, e.g. Para Gard, the surface of the cover ribbon behind the specimen clamping might be affected. For this reason, please note that the cover ribbon does not get in contact with these agents when cleaning the housing, knife carrier or the base plate.

#### Care

Remove the knife from the knife carrier. Clean it and keep it in a knife case.

**CAUTION!** Never put the knife with the cutting edge upward on the table.

For instruments with removable knife carriers, loosen the clamping lever on the left side of the knife carrier and pull the knife carrier off to the front.

Clean the operating controls and the surfaces of the knife carrier, especially the groove of the dovetail guide (if equipped) and the space where the knife carrier is installed.

Clean the dovetail guide (if equipped), turning knobs, specimen clamping system, specimen orientation as well as the base plate and housing.

## 6-2 DISPOSAL OF THE INSTRUMENT AFTER FINAL SHUTDOWN

After the final shutdown of the instrument, we recommend to contact a local recycling company for the disposal according to the national applicable regulations.



**To be applied in the countries of the European Union and other European countries with a separate collecting system within the waste management.**

The marking of the product and/or the respective literature indicates that, after its final shutdown, it must not be disposed of together with ordinary domestic waste.

- Please dispose of your instrument separately from other waste to not harm our environment and/or human health by uncontrolled waste disposal.
- Recycle your instrument to support the sustainable recycling of material resources.
- **Industrial users** should contact their suppliers and observe the conditions of the contract. This product must not be disposed of together with other commercial waste.
- **Please contact your supplier!!**