

Sliding Microtome

HM 430

Instruction Manual

CERTIFICATION

MICROM GmbH certifies that this instrument has been tested and checked carefully. Its technical data was verified before shipment to be in accordance with the published specifications.

The instrument complies with applicable international safety regulations.

WARRANTY

This MICROM product is warranted against defects in material and workmanship for a period of 1 year. Parts which prove to be defective during the warranty period will be repaired or replaced free of charge by MICROM International GmbH. No other warranty is expressed or implied. Unauthorized modification or repair by third party persons will void the warranty.

The warranty will expire in case of improper or wrong use of the instrument and in case the warning and precautionary messages are not observed. MICROM International GmbH is not liable for any occurring damage.

Errors and omissions excepted. Subject to amendment and improvement without further notice.

This instruction manual will be supplied together with each instrument. Further copies can be ordered at the nearest MICROM sales office by giving the serial number of the instrument, the number of the instruction manual and the date of issue.

This instruction manual is available in the following languages:

German:	387755
English:	387756
French:	387757
Spanish:	387758

INTENDED USE

Dear Customer,

Before operating the instrument, please read these instructions carefully to familiarize yourself with its proper operation and functions.

The MICROM sliding microtome HM 430 is a highly efficient sliding microtome for paraffin sectioning in routine.

Only skilled or specially trained personnel must operate the microtome, i.e. clamping the specimen, trimming, sectioning and taking off the sections from the instrument. The listed and marked safety measures as well as the regulations of your respective lab must be strictly observed.

MICROM Ser. No.

Please check the MICROM ser. no. on the type plate of your instrument and enter this number here.

Instruction Manual no. 387756

Issue: October 10, 2006

<p>MICROM International GmbH Robert-Bosch-Strasse 49 D-69190 Walldorf Telefon: (06227) 836-0 Telefax: (06227) 836-111</p>

Intended use

Table of contents

EC Certificate of Conformity

Safety Precautions

Part 1 Introduction

- 1-1 Description of the Sliding Microtome HM 430
- 1-2 Technical Data HM 430

Part 2 Operating Instructions

- 2-1 Setting up the microtome
- 2-2 Cutting movement
- 2-3 Locking the sledge
- 2-4 Specimen feed
 - 2-4-1 Setting section thickness
 - 2-4-2 Coarse feed
 - 2-4-3 Fine feed, manual
 - 2-4-4 Fine feed, automatic
 - 2-4-5 Moving the automatic feed position
- 2-5 Specimen clamping
 - 2-5-1 Standard specimen clamp
 - 2-5-2 Standard specimen clamp
 - 2-5-3 Universal cassette clamp
- 2-6 Changing the the specimen clamp
- 2-7 Knife carrier
 - 2-7-1 Blade carrier for disposable blades
- 2-8 Standard equipment
- 2-9 Additional equipment (optional)
 - 2-9-1 Disposable blade holder
 - 2-9-2 Specimen clamps
 - 2-9-3 Height adjustment plates
 - 2-9-4 Microtome knives
 - 2-9-5 Additional accessories

Part 3 Theory of operation

- 3-1 Cutting movement
- 3-2 Specimen coarse feed
- 3-3 Specimen clamping and specimen orientation
- 3-4 Knife carrier
- 3-5 Microtome with fast freezing unit

Part 4 Working with the microtome

4-1 Preparation and orientation

4-2 Coarse feed

4-3 Sectioning instructions

4-3-1 Condition of the knife edge

4-3-2 Clean knife surfaces

4-4 How to avoid malfunctions

4-4-1 Preparation of the specimen

4-4-2 Specimen temperature

4-4-3 Tightening the clamping screws

4-4-4 Selection of the knife

4-4-5 Adjustment of the knife

4-4-6 Cutting speed

4-4-7 Trimming

Part 5 Maintenance

Part 6 Cleaning and care

Part 7 Conditions for the transportation of the instrument

7-1 Taking back the instrument for repair or routine maintenance

7-2 Disposal of the instrument after final shutdown

EC Certificate of Conformity

Name and address of the manufacturer: MICROM International GmbH
Robert-Bosch-Straße 49
D-69190 Walldorf

Product designation: Sliding Microtome
Type reference: HM 430

Notification to Competent Authorities:

These medical device have been registered with the German authority as "Microtomes" under the EDMA-classification code: 23-06-02

The designated product complies with the laid down regulation:

**DIRECTIVE 98/79/EC OF THE EUROPEAN PARLIAMENT AND OF THE COUNCIL
of 27 October 1998
on in vitro diagnostic medical devices**

The designated product complies with the EC regulations by strictly observing the following norms:

DIN EN ISO 14971:2001-03

Medical devices - Application of risk management to medical devices (ISO 14971:2000).

DIN EN ISO 9001:2000

Quality management systems - Requirements (ISO 9001:2000)



Hans Heid
Managing Director

Walldorf, 11 May 2004

SAFETY PRECAUTIONS

WARNING SIGNALS AND SYMBOLS

The installation and routine use of the Sliding Microtome HM 430 is easy and safe if the instructions in this manual are being observed.



Note:

Special instructions regarding operation of the instrument.



Warning:

Special precautionary measures to prevent damage to equipment. For a long lifetime of the equipment, please observe these instructions carefully.



Caution – general danger spot:

The instruction manual must strictly be observed whenever this symbol is visible on the instrument.



Hazard of hand injuries:

Due to moving parts in connection also with the microtome knife, a danger area arises, which might lead to hand injuries in case of non-compliance with the safety features of the microtome and when disregarding the instruction manual.

Biohazard:

Warning of biological danger.



Radioactivity:

Warning of radioactive danger.



Separate taking back of electrical and electronic instruments in the countries of the European Union:

This is to be applied in the countries of the European Union and other European countries with a separate collecting system within the waste management.

This product, being an electro and/or electronic instrument, must be treated separately within the waste management process (WEEE).



SAFETY PRECAUTIONS**ATTENTION !**

The operator's safety is affected, when the instrument is not operated in accordance with the instruction manual.

Please observe the following general precautions during operation of this instrument. Failure to comply with these precautions violates safety standards and the intended use of the instrument. MICROM International GmbH is not liable for misuse of the instruments and failure to comply with basic safety requirements.

CARE IN USING MICROTOME KNIFE

To diminish the danger of being injured by the knife or blade, use the knife guard when adjusting specimen and knife. If possible, the specimen should be clamped in before the knife is inserted into the knife holder. Before changing the knife holder, always remove blade or knife! Unused knives should always be kept in a knife case. Never place the knife with the cutting edge upwards. Never try to catch a dropping knife!! Never check the sharpness of the cutting edge with your fingers. The cutting edge is extremely sharp!

DANGER IN EXPLOSIVE ENVIRONMENT

The instrument must not be operated in the presence of flammable gases. Moreover, the instrument must not be exposed to conditions whereby dangerous gas concentrations can occur.

HAZARD OF RADIOACTIVE RADIATION

When working with radioactive specimens observe all applicable radiation safety procedures. When working with radioactive contaminated material, appropriate safety and disinfection measures must be carried out. According to the rules and regulations concerning the handling of radioactive contaminated material of the respective laboratory, safety clothing (e.g. particle mask, gloves, protective shoe covers) must be worn. Radioactive contaminated waste must be disposed of according to the respective regulations.

HAZARD OF INFECTION



Specimens used during the intended operation of the instrument might potentially be infectious. For this reason, it is recommended to observe the general laboratory regulations concerning protection against danger of infection.

Information on decontamination media, their use, dilution and effective range of application can be read in the Laboratory Biosafety Manual : 1984 of the World Health Organization.

When working with infectious specimens observe all applicable safety procedures. When working with infectious material, appropriate safety and disinfection measures must be carried out. According to the rules and regulations concerning the handling of infectious material of the respective laboratory, safety clothing (e.g. particle mask, gloves, protective shoe covers) must be worn. Infectious waste must be disposed of according to the respective regulations.

HAZARD OF MALFUNCTION

To avoid the hazard of malfunction of an instrument, it must only be operated in a controlled electromagnetic environment. This means that transmitters such as mobile phones must not be operated in their close vicinity.

In case of malfunctions and/or service work, please turn off the instrument and contact your local dealer.

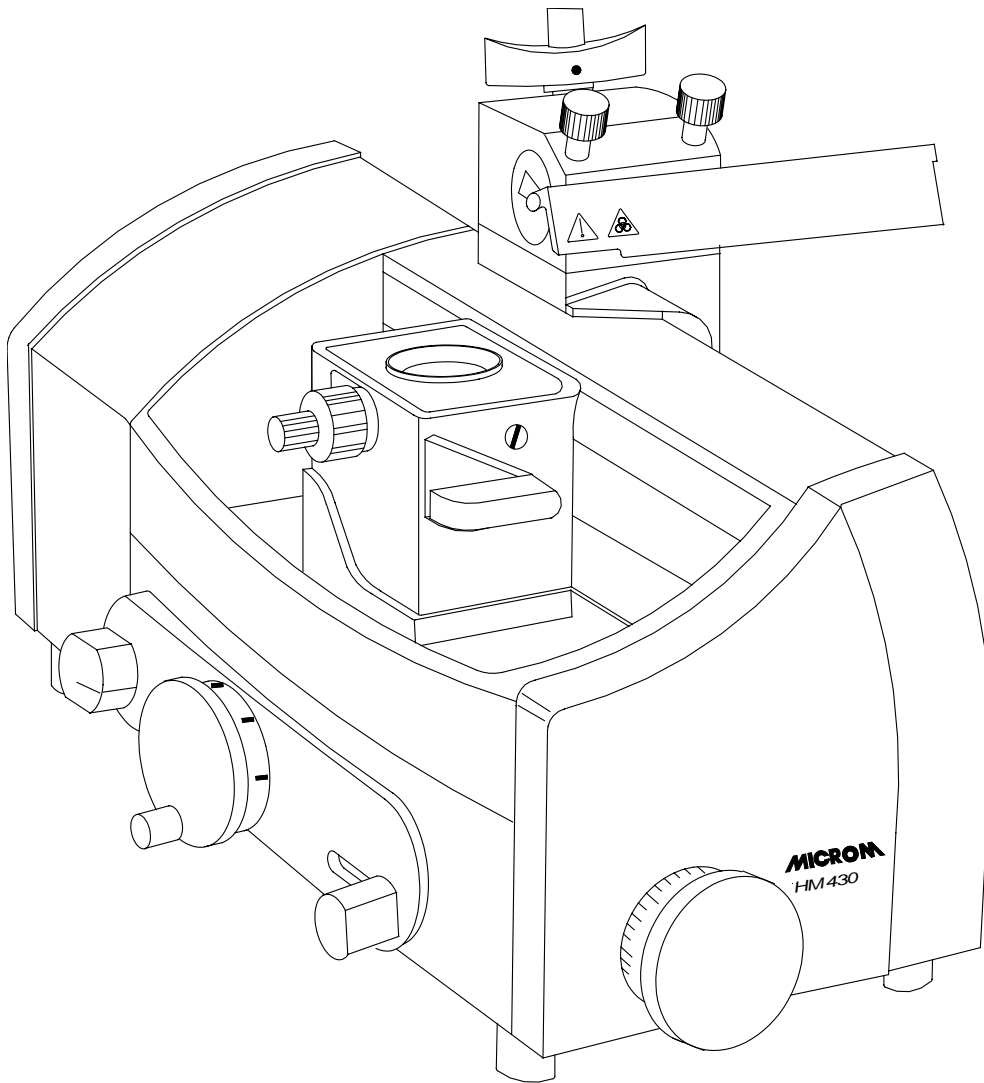

Fig. 1

PART 1 INTRODUCTION

1-1 DESCRIPTION OF THE SLIDING MICROTOME HM 430

The sliding microtome HM 430 from MICROM International GmbH is a highly efficient instrument for sectioning paraffin in routine and research. The main applications are in human and veterinary medicine. Large and hard specimens from pharmaceuticals industry or from quality assurance labs can also be sectioned.

The cross roller bearings on sledge and block allow non-tiring working and a smooth sliding movement with optimal stability.

The HM 430 will cut sections from 1 µm to 60 µm. The specimen clamping can be moved up and downwards via the coarse feed wheel with crank handle on the left side of the instrument. This way, specimen and knife edge distance can be adjusted quickly.

The knife carrier is designed so the knives can be easily clamped in place and adjusted.

The coaxial specimen orientation allows orientation with one hand.

1-2

TECHNICAL DATA HM 430

Microtome:	Section thickness range: 0,5 - 60 µm Resolution:..... 0,5 µm for 0 ... 5 µm 1 µm for 5...10 µm 2 µm for 10...20 µm 5 µm for 20...60 µm
	Vertical feed rangemax. 40 mm Horizontal knife strokemax. 190 mm
Cutting drive: manual sliding movement
Coarse feed:manual via coarse feed wheel
Feed:automatic via sliding movement or manual via feed lever
Specimen size:up to max. 80 x 60 mm
Specimen orientation:	x - and y - axes: universal 8°
Transportation- & storage conditions:	
Storage temperature range: -20°C up to +50°C
Operating conditions:+5°C up to +35°C (at a max. rel. humidity of 60%)for indoor use only Floor loading requirements: 150 kg/m ²
Pollution degree:2
Overvoltage category:II
Dimensions:	wide: 360 mm, deep: 490 mm, high: 320 mm
Weight:	23 kg

PART 2 OPERATING INSTRUCTIONS

2-1 SETTING UP THE MICROTOME



Note:

The kind of the used examination materials and all special conditions for their processing, pre-treatment and, if necessary, storage as well as instrument controls for correct and safe operation is in the responsibility of the operator.

The operator is also responsible for special equipment and materials and/or reagents for the operation of the instrument.

- Unpack the microtome and remove the wrapping.
- To carry the instrument, lift it on the front and rear side from the lower side.



Warning:

Do not carry the instrument on the handle of the knife sledge!

- Place the instrument on an even surface in a way that the knife guidance is moved towards the user and away from him.
- The coarse feed wheel should show to the left side and the knife carrier handle to the right side.



Note:

Sectioning can be influenced by nearby instruments which generate vibrations. For this reason, the microtome should be placed on a stable and vibration free table.



Note:

The standard equipment includes four rubber feet which are smaller than the ones that were installed in our factory. Should the working height be too high when setting up the microtome, unscrew the original feet and replace them with the lower ones.

2-2 CUTTING MOVEMENT

- To start the cutting movement of the microtome, move the sledge horizontally.
- The knife (or blade) which is clamped into the knife carrier is drawn horizontally over the specimen towards the user. This way, sections are produced.
- In the front reversal point of the sliding movement, i.e. when the sledge is moved again backwards, the preselected section thickness is delivered either manually via a lever or automatically by moving over the advance position.
- This way, the specimen is moved in vertical direction towards the knife with the selected section thickness and a new section can be made.

2-3 LOCKING THE SLEDGE

For the protection against injury by unintended movements of the knife sledge, the microtome is equipped with a lock of the sledge in any position.



Caution:

The sledge should be locked for the user's personal safety, e.g. when new specimens are clamped into position, knives are exchanged, the instrument is cleaned or other adjustment processes are carried out.

- The lock is released via a lever on the rear side of the sledge and is easily accessible from the right side behind the handle.

Locking the sledge:

- Swivel the locking lever from the upper position (fig. 2.1) into the lower position (fig. 2.2).
- Then the red marked lever surface becomes visible to show the clamped state.

Loosening the sledge:

- Swivel the lever from the lower position (fig. 2.2) into the upper position (fig. 2.1) until the red mark cannot be seen anymore.
- The knife sledge can be moved again.

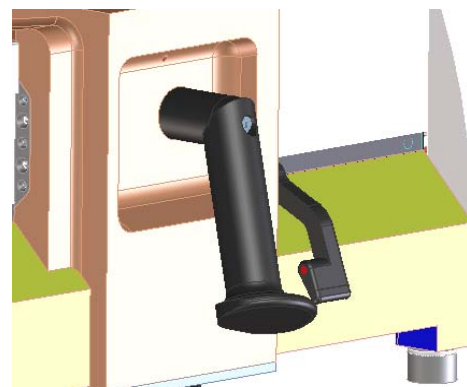
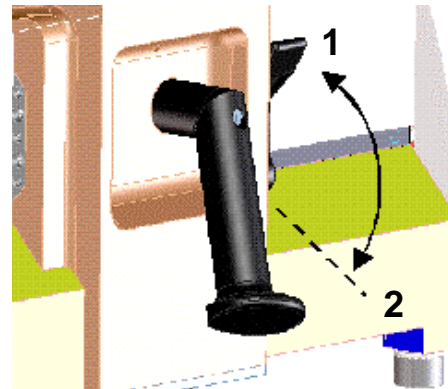

Fig. 2

2-4 SPECIMEN FEED

2-4-1 SETTING SECTION THICKNESS

The required section thickness is set by turning the scaled wheel on the front side of the instrument to left or right side. The setting is locking and the currently selected value can be read on the highest point of the scale opposite the index marking (fig. 3.1).

The graduation of the section thicknesses is divided into four ranges:

range	graduation
from 0,5 μm to 5 μm	0,5 μm
from 5 μm to 10 μm	1 μm
from 10 μm to 20 μm	2 μm
from 20 μm to 60 μm	5 μm

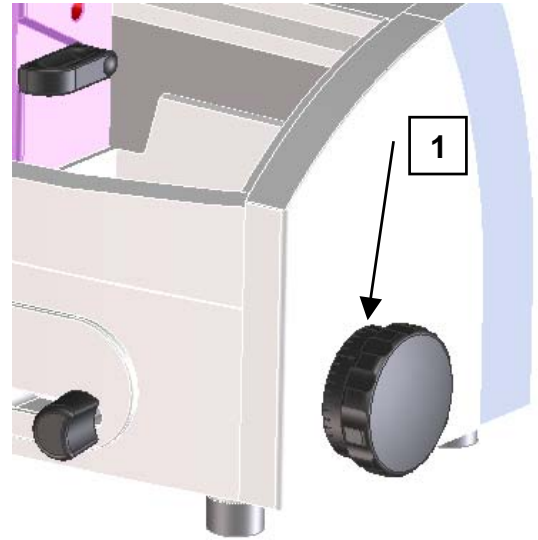

Fig. 3

2-4-2 COARSE FEED

For the fast up and downward travel between specimen and knife edge as well as for trimming, the microtome has a coarse feed with vertical direction.

- The specimen clamping can be moved 40 mm vertically up or downwards via the coarse feed wheel (fig. 4).
- Turn the wheel in a clockwise direction, the specimen clamping moves upwards towards the knife.
- Turn the wheel in a counter-clockwise direction, the specimen moves downwards away from the knife.



Warning:

If the specimen clamping is moved upwards until a red line (fig. 4a) can be seen, the end of the feed range is nearly achieved. Approx. 3 mm of feed range is still available.

Do not cross over this upper end position by applying more force. Non-observance leads to damage on the instrument!!!

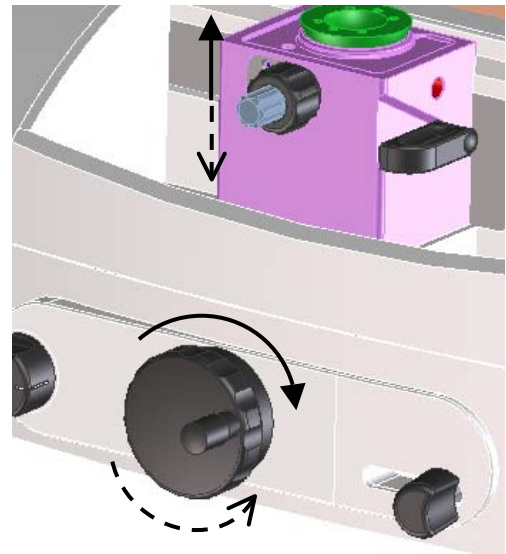

Fig. 4

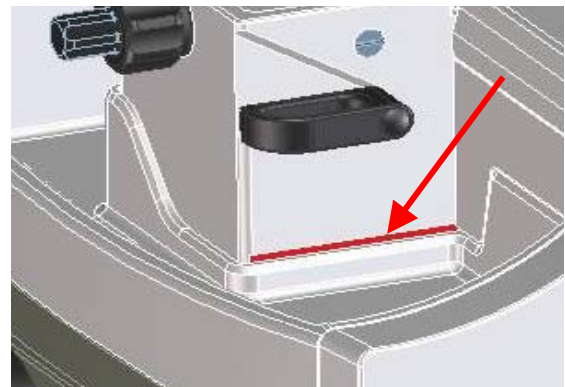
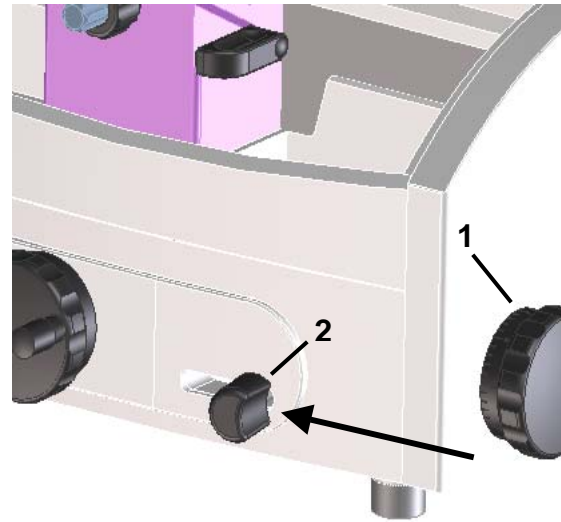

Fig. 4a

2-4-3 FINE FEED, MANUAL

After having adjusted knife and specimen as well as having trimmed the specimen, sectioning can be started.

- The feed of the section thickness which was preselected on the scaled wheel (fig. 5.1) is carried out either automatically by moving the knife sledge over integrated, selectable feed point or by manually activating the feed device.
- The manual feed is carried out by press the feed lever (fig. 5.2)
- For this, the knife sledge is moved behind the specimen and the feed lever is activated once in the direction of arrow.
- Afterwards pull the knife sledge towards the front to generate a section.
- Press the feed lever several times, the set section thickness can be multiplied accordingly.



Warning:

If a red line (fig. 5a) can be seen during sectioning, the end of the feed range is nearly achieved. Approx. 3 mm of feed range is still available. Afterwards, the end of the feed range can be noticed by a higher force application on the feed lever.

Do not carry out feed by applying more force. However, move the specimen clamping again into a deeper position via the coarse feed wheel as soon as possible.

Non-observance leads to damage on the instrument!!!

Fig.



Fig. 5a

2-4-4 FINE FEED, AUTOMATIC

- The feed of the section thickness which was preselected on the scaled wheel (fig. 5.1) is carried out either automatically by moving the knife sledge over integrated, selectable feed point or by manually activating the feed device.
- The automatic feed is carried out by moving the knife sledge into a selectable position behind the specimen. This feed process can be noticed by a slight resistance when moving the knife sledge.
- The automatic feed can easily be turned on and off.
- For this, turn the turning knob (fig. 6.1) behind the coarse feed wheel forwards or backwards to the respective stop.
- When the index mark on the turning knob shows towards the front and thus visible for the operator (position **A**utomatic), the automatic feed is turned on.
- When the index mark shows on the knob shows towards the rear, the automatic feed is turned off (position **M**anual).

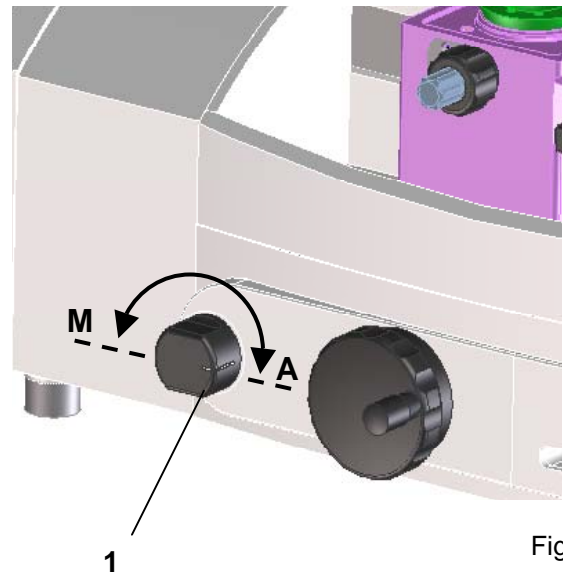

Fig. 6



Note:

For optimal sections, always move the sledge together with the knife to the rear side over the entire specimen and then move it forwards.



Warning:

Turning on and off the automatic position is not possible when the knife sledge is in the rear position.



Warning:

If a red line (fig. 6a) is seen during sectioning, the end of the feed range is nearly achieved. Approx. 3 mm of feed range is still available.

Do not apply more force for carrying out the feed. However, move the specimen clamping again into a deeper position via the coarse feed wheel as soon as possible.

Non-observance leads to damage on the instrument!!!

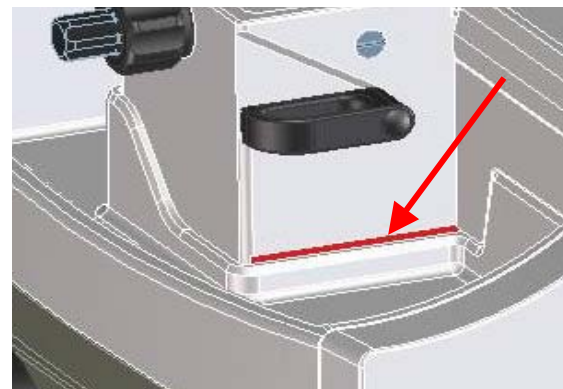

Fig. 6a

2-4-5 MOVING THE AUTOMATIC FEED POSITION

The automatic feed is carried out by moving the knife sledge into a selectable position behind the specimen.

The knife sledge position on which the feed of the preselected section thickness is carried out, can be chosen within a wide range to accommodate various specimen sizes. Therefore, it is possible to set the automatic advance position close behind the specimen to avoid useless sledge travel distances.

- For this move the knife sledge into the position where the automatic feed is to be carried out.
- Secure the knife sledge via the locking lever into position.
- Loosen the clamping lever on the lower side of the knife sledge and move the entire lever mechanism forwards and backwards until a slight resistance can be noticed.
- Tighten the clamping lever again.
- Loosen the sledge lock and move over the specimen.
- When returning again over the specimen, a feed is carried out in new selected position.

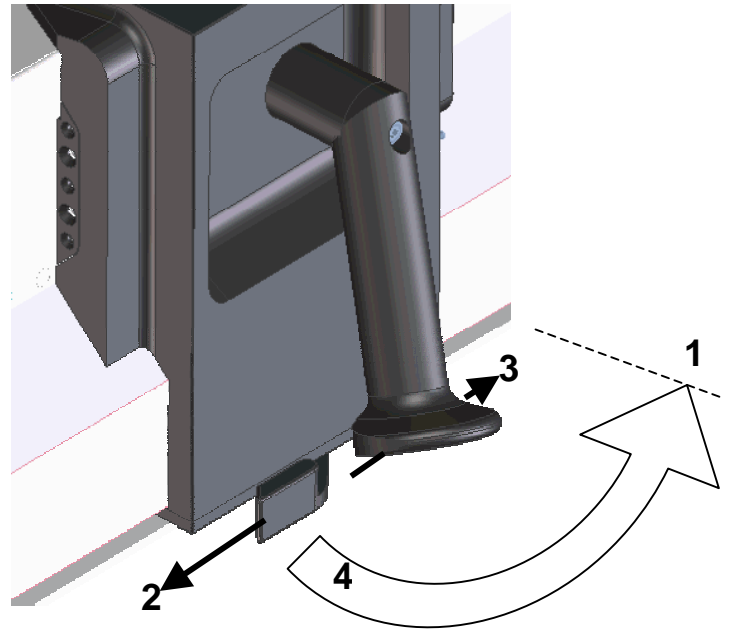

Fig. 7

2-5 SPECIMEN CLAMPING

To clamp specimens, different specimen clamping systems are available. With the orienting adapter it is simple to align the specimen properly in relation to the knife.

2-5-1 STANDARD SPECIMEN CLAMP (Cat. no. 715480)

The standard specimen clamp is used for rectangular and square paraffin blocks.

- Insert the specimen on the front fixed jaw (fig. 8.2) and tighten it via the clamping screw (fig. 8.3) with the movable jaw (fig. 8.1).



Warning:

For the stability of the specimen, do not let it project over the clamping jaws too much!

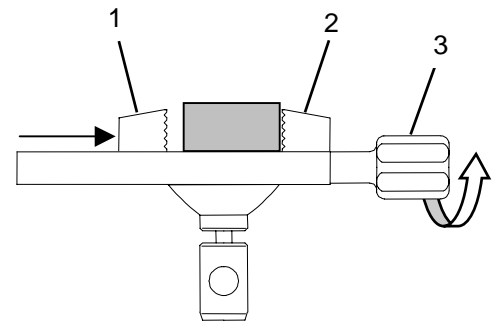

Fig. 8

2-5-2 STANDARD SPECIMEN CLAMP

- This specimen clamp is used in the same way as the above-described standard specimen clamp (see cat. no. 715480).
- The clamping screw and thus the clamping direction of this clamp is arranged transversely in relation to the sectioning direction.
- Specimens with a size up to 45 x 60 mm can be inserted.



Warning:

For the stability of the specimen, do not let it project over the clamping jaws too much!

2-5-3 UNIVERSAL CASSETTE CLAMP (Cat. no. 715500)

The universal cassette clamp represents a quick change system for standardized embedding cassettes.

- To insert or remove cassettes, press the lever (fig. 9.1) upwards.

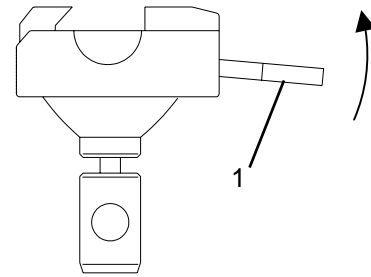

Fig. 9

2-6 CHANGING SPECIMEN CLAMPS

Due to the quick change system of the specimen clampings, specimen clamps can be easily and rapidly changed without needing any tools.

- Loosen the clamping of the specimen clamp (fig. 10.1).
- Set the specimen clamp horizontally by means of the set screws of the orientation device.
- To replace the specimen clamp turn the eccentric lever downwards (fig. 10.1) to the stop and pull it off (fig. 10.2).
- Now the specimen clamp can be removed and replaced with another one.



Note:

Before inserting another clamp, please note the position of the hole in the adapter! It must be aligned in longitudinal direction of the instrument so that the eccentric lever can be pushed in again.

- Again push the eccentric lever into the specimen block.
- Then press the eccentric lever upwards to fix the specimen clamp in position.

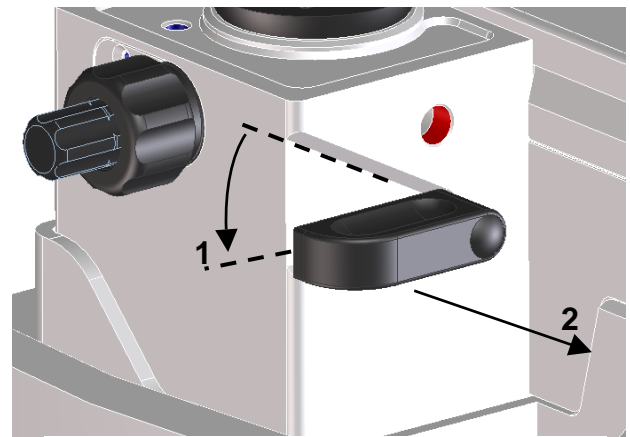

Fig. 10

2-7 KNIFE CARRIER



Hazard of hand injuries:

Due to moving parts in connection also with the microtome knife, a danger area arises, which might lead to hand injuries in case of non-compliance with the safety features of the microtome and when disregarding the instruction manual.

The knife carrier of the microtome is easy to use and equipped with a knife guard for user safety while adjusting knife and specimen.



Caution:

While working on the knife carrier, it should be locked with the locking device of the sledge (see part 2-4).

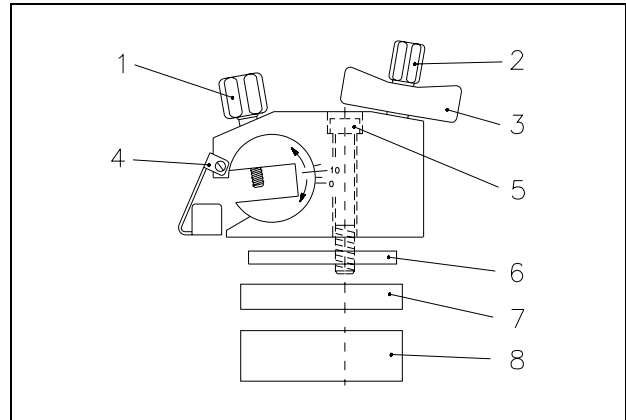

Fig. 11

Inserting the knife

- To insert the knife, slightly unscrew the two clamping screws (fig. 11.1) until the knife can be pushed in from the side.
- Then tighten the two clamping screws to fix the knife in its position.

Clearance angle adjustment

The clearance angle between cutting edge and specimen can be adjusted very easily to the respective requirements of the tissue to be sectioned without loosening the clamping of the knife.

- For this, use the two coaxial screws (fig. 11.2 and 11.3) on the upper side of the knife carrier.
- Loosen the clamping screw (fig. 11.3) in a counter-clockwise direction and adjust the clearance angle by means of the set screw (fig. 11.2).
- The adjusted clearance angle can be read on the scale which is on the right side of the knife carrier.
- Then tighten the screw (fig. 11.3) in a clockwise direction to fix the clearance angle.



Note:

By experience, usable cuts are only achieved at a clearance angle of 10° or more.

Protection against injury

- The knife carrier is equipped with a knife guard (fig. 11.4) which should be used while knife or specimen are adjusted.



Caution:

Please note that knives with a length of more than 16 cm (e.g. 22 cm) and/or if it is clamped too much on one side, projects over the knife guard resulting in possible hazards of being injury although the knife guard is used.

Moving the knife sideways

- If the cutting edge of the knife is blunt, loosen the clamping screws (fig. 11.1) and move the knife to the left or right side.
- This process can also be used to protect the knife, as for trimming and fine sectioning different parts of the knife can be used.

Diagonal position of the knife

- After having loosened the central fastening screw of the knife carrier (fig. 11.5) via the attached hex head wrench (size 6), the knife can be adjusted diagonally according to the tissue to be sectioned. This is called "angle cut".
- However, please note that due to the diagonal positioning the usable width of the specimen decreases!

Height adjustment plates (optional)

In case the height adjustment of the specimen block is not sufficient for cutting high specimens, a height adjustment plate can be mounted between knife carrier and sledge.

Height adjustment plates are available with 5 mm, 10 mm and 20 mm.

Knife profile

Knives with profile c and d are available. The opposite figure (fig. 12.) shows schematically the angles on the cutting edge profiles of c- and d-knives.

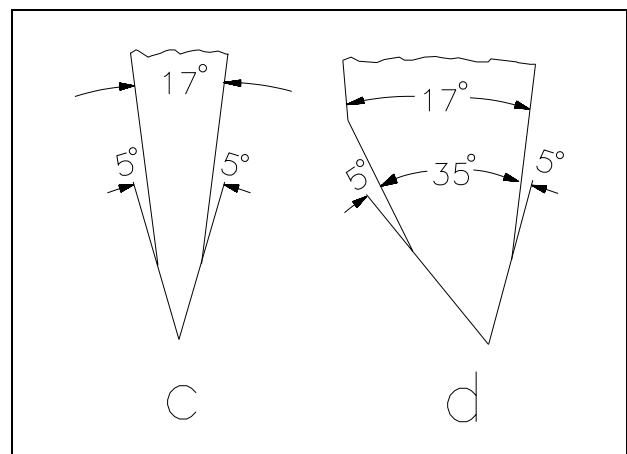

Fig. 12

2-7-1 BLADE HOLDER FOR DISPOSABLE BLADES

Two different types of disposable blades are available: low profile blades (height: 8 mm) and high profile blades (height: 14 mm). When using disposable blades, a blade holder together with a disposable blade is clamped into the knife carrier.

Klinge einlegen

- Insert the blade holder into the knife carrier from the left side and tighten the two clamping screws on the knife carrier.
- The clamping lever on the blade holder can be positioned in two ways: 0 = loosened, 1 = clamped (fig. 13).
- To insert the blade, turn the clamping lever to 0.
- Please note that locating and clamping surfaces are clean!!
- To clamp the blade, turn the clamping lever to 1.

Clearance angle adjustment.

- The clearance angle between blade and specimen must be adjusted in the same way as the clearance angle between knife and specimen is adjusted.

Protection against injury

- The knife carrier of the instrument is equipped with a knife guard which can be moved sideways.
- This knife guard should be used while knife and specimen are adjusted.
- This reduces the danger of injury considerably!

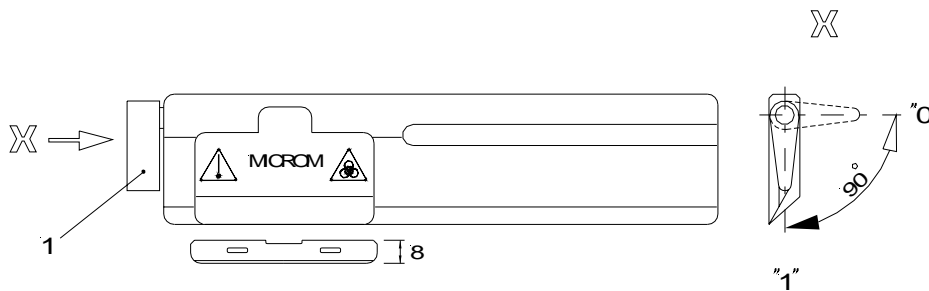

Fig. 13

2-8 STANDARD EQUIPMENT

The microtome HM 430 is supplied with the following accessories:

- 1 hex head wrench 5 mm
- 1 hex head wrench 6 mm
- 1 cover
- 4 rubber feet with lower height
- 1 instruction manual

2-9 ADDITIONAL EQUIPMENT (OPTIONAL)**2-9-1 DISPOSABLE BLADE HOLDER****Cat. no.**

- Blade holder with eccentric fast clamping
- for low profile blades
- for high profile blades

705200
705340

- Case for disposable blade holder
- Cat. no. 705200 and 705340

152160

- Blade holder with Allen key
- for one low profile blade
- for two low profile blades

705430
705440

2-9-2 SPECIMEN CLAMPS

- Universal cassette clamp

715500

- Standard specimen clamp, 45 x 80 mm

715480

2-9-3 HEIGHT ADJUSTMENT PLATES

5 mm	448070
10 mm	440400
20 mm	440410

2-9-4 MICROTOME KNIVES

Steel knives, type c

16 cm	152020
18,5 cm	152270
22 cm	152030
25 cm	152040
30 cm	152050

Steel knives, type d

16 cm	152070
22 cm	152080
25 cm	152090
30 cm	152100

Tungsten carbide knife 16 cm, d 152120

Knife case

16 cm	152230
18,5 cm	152280
22 cm	152240
25 cm	152250
30 cm	152260

Disposable blades for paraffin
EdgeRite low profile blade, 50 pcs. in dispenser 152500

2-9-5 ADDITIONAL ACCESSORIES

Fast freezing unit K 400 (standard specimen clamp is necessary)	770040
Para Gard (paraffin repellent), 100 ml	350170

PART 3 THEORY OF OPERATION

3-1 CUTTING MOVEMENT

The sliding microtome HM 430 has high-precision, zero-backlash linear roller bearings (cross roller bearings) for the bearing of the knife sledge and the block.

These cross roller bearings allow a zero-backlash feed of the knife sledge.

The knife sledge cannot be removed from the user, however, it is restricted guided and always remains on the instrument.

The cutting movement of the microtome is generated by horizontally moving the sledge in the cross roller bearings. Here the knife, which is clamped into the knife carrier, is horizontally drawn over the specimen towards the user and away from him. This way, sections are produced. After having moved the knife sledge backwards into the rear end position, a preselected section thickness is carried out either manually via a lever or automatically due to moving the sledge over an automatic advance position.

The specimen is delivered towards the knife with the preselected section thickness in vertical direction and a new section is produced.

3-2 SPECIMEN COARSE FEED

After changing the specimen or moving the knife or knife carrier, it is necessary to adjust the specimen to the knife edge again. This can easily be done by means of the specimen coarse feed wheel on the left side of the instrument.

3-3 SPECIMEN CLAMPING SYSTEM AND SPECIMEN ORIENTATION

According to the form and size of the specimens, different specimen clamping systems are available to carry the specimen. It is very easy to align the specimen to the knife, using the orienting adapter.

3-4 KNIFE CARRIER

The knife carrier is easy to use and allows the microtome knives to be clamped and adjusted as needed. Depending on application, knives or disposable blades can be used.

3-5 MICROTOME WITH FAST FREEZING UNIT

The fast freezing unit K 400 allows frozen sectioning with the specimen temperature as low as -45°C.

PART 4 WORKING WITH THE MICROTOME

4-1 PREPARATION AND ORIENTATION

Before sectioning, the specimens must be prepared appropriately and embedded in suitable media. Cassettes as well as different forms for round and rectangular specimens can be used for embedding.

With the orienting adapter, the specimen can easily be oriented to the knife.

4-2 COARSE FEED

To adjust approximately the space between specimen and cutting edge, use the coarse feed or the trimming function. Continue this to start trimming the specimen, thus achieving the level of interest. Any waste should be wiped away in a forward direction with a brush.

4-3 SECTIONING INSTRUCTIONS



Hazard of hand injuries:

Due to moving parts in connection also with the microtome knife, a danger area arises, which might lead to hand injuries in case of non-compliance with the safety features of the microtome and when disregarding the instruction manual.

To cut usable sections, the following points are of utmost importance:

4-3-1 CONDITION OF THE KNIFE EDGE

Use a sharp knife only! If the knife edge is blunt, move the knife horizontally either to the right or left side to continue working with the sharp area of the cutting edge, or have the knife resharpened.

4-3-2 CLEAN KNIFE SURFACES

For optimal sectioning, front and back of the knife must be clean. Especially, paraffin waste must be removed thoroughly!!

4-4 HOW TO AVOID MALFUNCTIONS

4-4-1 PREPARATION OF THE SPECIMEN

When preparing specimens, be sure that a suitable embedding medium, fixation, dehydration and infiltration time are chosen.

4-4-2 SPECIMEN TEMPERATURE

Sectioning is carried out at ambient temperature (excluding frozen sections). If the temperature is too high, the paraffin softens. Therefore, avoid heating paraffin specimens by direct exposure to sunlight or other near sources of heat.

4-4-3 TIGHTENING THE CLAMPING SCREWS

Tighten all clamping screws and clamping levers on the knife carrier, specimen holder and specimen orientation.

4-4-4 SELECTION OF THE KNIFE

Carefully select the required knife material and profile.

4-4-5 ADJUSTMENT OF THE KNIFE

Take care to adjust the proper clearance angle of the knife.

Select a clearance angle adjustment of 10° or more according to the facet angle.

4-4-6 CUTTING SPEED

Take care to select proper cutting speed.

General Rule: The harder the material, the slower the cutting speed!!

4-4-7 TRIMMING

Take care in bringing the knife and specimen together.

PART 5 MAINTENANCE

Annual routine maintenance

To secure section quality and functioning of the microtome, it is recommended that a **routine maintenance** be performed by a trained service technician **once a year**.

Service contract

MICROM offers a service contract which guarantees that your instrument is always in perfect condition. For more information, please contact the nearest MICROM sales office.

PART 6 CLEANING AND CARE

Cleaning intervals

Cleaning, care and decontamination of the microtome depends on how frequently the microtome is used. For optimal sectioning, the instrument must be free of section waste, especially the guides and clamping mechanism.

Cleaning agents

Mild household cleaners can be used to clean the microtome. Do not use aggressive cleaners or solvents, as the paint and plastic parts can be affected.



Note:

Before starting cutting, instrument, knife carrier and section waste trays should be treated with a commercially available paraffin repellent, e.g. Para Gard.



Caution:

Never dump the instrument in any liquid. For cleaning purposes, use a slightly moistened cleaning cloth only!

Care

- Remove the knife from the knife carrier.
- Clean it with a dry cloth to avoid the formation of rust and keep it in a knife case.



Caution:

Never put the knife with the cutting edge upwards on the table!

- Clean the operating controls and the surfaces of the knife carrier, especially the space where the knife is installed.
- The maintenance-free cross roller bearings are covered and protected against dust and section waste and need not to be lubricated or cleaned by the customer.
- Clean the specimen clamping system, specimen orientation, housing and vertical carrier.

PART 7 CONDITIONS FOR THE TRANSPORTATION OF THE INSTRUMENT

7-1 TAKING BACK THE INSTRUMENT FOR REPAIR OR ROUTINE MAINTENANCE

Repair or maintenance work are normally carried out at the site of installation. If this is not possible for some special reasons, the instrument can be returned to MICROM. The contact address can be found at the beginning of this instruction manual.

- To guarantee trouble-free function of the instrument after transportation, please note the below-mentioned measures for the transportation preparation.
- In addition, the conditions for storage and transportation as mentioned in part 1-2 must be observed during the entire transportation.

Biohazard:



Please also note the precautionary measures described in our safety precautions concerning biological hazards!

Measures for closing down:

- Remove knife or blade and store it in a safe way.
- Secure the sledge via the lock of the sledge as described in part 2-4.



Note:

The locking of the sledge functions as a brake. In case the instrument is kept in an inclined way, the braking power might not be sufficient enough to avoid that the sledge moves.

- To lift the instrument, take it on each fore-parts. During transportation, do not carry the instrument on the handle. Danger of injury!

**For transportation outside closed buildings,
please observe the following measures:**

- Remove knife or blade and store it in a safe way.
- Secure the sledge via the lock of the sledge as described in part 2-4.



Note:

The locking of the sledge is functions as a brake. In case the instrument is kept in an inclined way, the braking power might not be sufficient enough to avoid that the sledge moves.

- To lift the instrument, take it on each fore-parts. During transportation, do not carry the instrument on the handle. Danger of injury!
- Pack the instrument into the original packing as it offers best pre-conditions for transportation without damage.



Note:

If the original packing is no longer available, please contact your local MICROM representation.

7-2 DISPOSAL OF THE INSTRUMENT AFTER FINAL SHUTDOWN

After the final shutdown of the instrument, we recommend to contact a local recycling company for the disposal according to the national applicable regulations.



To be applied in the countries of the European Union and other European countries with a separate collecting system within the waste management.

The marking of the product and/or the respective literature indicates that, after its final shutdown, it must not be disposed of together with ordinary domestic waste.

- Please dispose of your instrument separately from other waste to not harm our environment and/or human health by uncontrolled waste disposal.
- Recycle your instrument to support the sustainable recycling of material resources.
- **Industrial users** should contact their suppliers and observe the conditions of the contract. This product must not be disposed of together with other commercial waste.
- **Please contact your supplier!!**