

Sliding Microtome

HM 450

Instruction Manual

CERTIFICATION

MICROM GmbH certifies that this instrument has been tested and checked carefully. Its technical data was verified before shipment to be in accordance with the published specifications.

The instrument complies with applicable international safety regulations.

WARRANTY

This MICROM product is warranted against defects in material and workmanship for a period of 1 year. Parts which prove to be defective during the warranty period will be repaired or replaced free of charge by MICROM International GmbH. No other warranty is expressed or implied. Unauthorized modification or repair by third party persons will void the warranty.

The warranty will expire in case of improper or wrong use of the instrument and in case the warning and precautionary messages are not observed. MICROM International GmbH is not liable for any occurring damage.

Errors and omissions excepted. Subject to amendment and improvement without further notice.

This instruction manual will be supplied together with each instrument. Further copies can be ordered at the nearest MICROM sales office by giving the serial number of the instrument, the number of the instruction manual and the date of issue.

This instruction manual is available in the following languages:

	Cat. no.
German:	387759
English:	387760
French:	387761
Spanish:	387762

INTENDED USE

Dear Customer,

Before operating the instrument, please read these instructions carefully to familiarize yourself with its proper operation and functions.

The MICROM sliding microtome HM 450 is a highly efficient sliding microtome for paraffin sectioning in routine.

Only skilled or specially trained personnel must operate the microtome, i.e. clamping the specimen, trimming, sectioning and taking off the sections from the instrument. The listed and marked safety measures as well as the regulations of your respective lab must be strictly observed.

MICROM Ser. No.

Please check the MICROM ser. no. on the type plate of your instrument and enter this number here.

Instruction Manual no. 387760

Issue: September 28, 2005

<p>MICROM International GmbH Robert-Bosch-Strasse 49</p> <p>D-69190 Walldorf</p> <p>Telefon: (06227) 836-0 Telefax: (06227) 836-111</p>

Intended use

Table of contents

EC Certificate of Conformity

Safety Precautions

Part 1	Introduction
1-1	Description Sliding Microtome HM 450
1-2	Technical Data HM 450
Part 2	Operating Instructions
2-1	Setting up the microtome
2-2	Initial turn-on
2-3	Cutting movement and retraction
2-4	Locking the sledge
2-5	Setting section thickness and trimming thickness
2-6	Specimen feed
2-6-1	Coarse feed
2-6-2	Trimming and first cuts
2-6-3	Fine feed, manual
2-6-4	Fine feed, automatic
2-6-5	Retract function for compensating the thermal extension
2-7	Operating panel
2-8	Keyboard
2-8-1	Scroll button
2-8-2	Reset button
2-8-3	Memory button
2-8-4	Menu button
2-8-4-1	Automatic/Manual
2-8-4-2	Retraction on/off
2-8-4-3	Speed for coarse feed
2-8-4-4	Language selection
2-8-4-5	Selecting the display mode
2-8-4-6	Time and date
2-8-4-7	Service menu
2-9	Specimen clamping
2-9-1	Standard specimen clamp
2-9-2	Standard specimen clamp
2-9-3	Universal cassette clamp
2-10	Changing the specimen clamp
2-11	Knife carrier
2-11-1	Blade holder for disposable blades

- 2-12 Standard equipment
- 2-13 Additional equipment (optional)
 - 2-13-1 Disposable blade holder
 - 2-13-2 Specimen clamps
 - 2-13-3 Height adjustment plates
 - 2-13-4 Microtome knives
 - 2-13-5 Additional accessories

- Part 3 Theory of operation
 - 3-1 Cutting movement
 - 3-2 Specimen coarse feed and trimming function
 - 3-3 Specimen clamping and specimen orientation
 - 3-4 Knife carrier
 - 3-5 Microtome with fast freezing unit

- Part 4 Working with the microtome
 - 4-1 Preparation and orientation
 - 4-2 Coarse feed and trimming function
 - 4-3 Sectioning instructions
 - 4-3-1 Condition of the knife edge
 - 4-3-2 Clean knife surfaces
 - 4-4 How to avoid malfunctions
 - 4-4-1 Preparation of the specimen
 - 4-4-2 Specimen temperature
 - 4-4-3 Tightening the clamping screws
 - 4-4-4 Selection of the knife
 - 4-4-5 Adjustment of the knife
 - 4-4-6 Cutting speed
 - 4-4-7 Trimming

- Part 5 Maintenance

- Part 6 Cleaning and care

- Part 7 Conditions for the transportation of the instrument
 - 7-1 Taking back the instrument for repair or routine maintenance
 - 7-2 Disposal of the instrument after final shutdown

EC Certificate of Conformity

Name and address of the manufacturer: MICROM International GmbH
Robert-Bosch-Straße 49
D-69190 Walldorf

Product designation: Sliding Microtome
Type reference: HM 450

Notification to Competent Authorities:

These medical device have been registered with the German authority as "Microtomes" under the EDMA-classification code: 23-06-02

The designated product complies with the laid down regulation:

**DIRECTIVE 98/79/EC OF THE EUROPEAN PARLIAMENT AND OF THE COUNCIL
of 27 October 1998
on in vitro diagnostic medical devices**

The designated product complies with the EC regulations by strictly observing the following norms:

DIN EN ISO 14971:2001-03

Medical devices - Application of risk management to medical devices (ISO 14971:2000).

DIN EN 61010-1:2002-08

Safety requirements for electrical equipment for measurement, control and laboratory use - Part 1: General requirements (IEC 61010-1:2001).

DIN EN 61010-2-101:2003-09

Safety requirements for electrical equipment for measurement, control and laboratory use - Part 2-101: Particular requirements for In-Vitro-Diagnostic-(IVD)-Medical instruments.

DIN EN 61326:2002-03

Electrical equipment for measurement, control and laboratory use - EMC requirements (IEC 61326-1:1997 + A1:1998 + A2:2000); German version EN 61326:1997 + A1:1998 + A2:2001

DIN EN ISO 9001:2000

Quality management systems - Requirements (ISO 9001:2000)



Hans Heid
Managing Director

Walldorf, 10 February 2004

SAFETY PRECAUTIONS

WARNING SIGNALS AND SYMBOLS

The installation and routine use of the Sliding Microtome HM 450 is easy and safe if the instructions in this manual are being observed.



Note:

Special instructions regarding operation of the instrument.



Warning:

Special precautionary measures to prevent damage to equipment. For a long lifetime of the equipment, please observe these instructions carefully.



Caution – general danger spot:

The instruction manual must strictly be observed whenever this symbol is visible on the instrument.



Hazard of hand injuries:

Due to moving parts in connection also with the microtome knife, a danger area arises, which might lead to hand injuries in case of non-compliance with the safety features of the microtome and when disregarding the instruction manual.

Biohazard:

Warning of biological danger.



Radioactivity:

Warning of radioactive danger.



Separate taking back of electrical and electronic instruments in the countries of the European Union:



This is to be applied in the countries of the European Union and other European countries with a separate collecting system within the waste management.

This product, being an electro and/or electronic instrument, must be treated separately within the waste management process (WEEE).

SAFETY PRECAUTIONS

ATTENTION !

The operator's safety is affected, when the instrument is not operated in accordance with the instruction manual.

Please observe the following general precautions during operation of this instrument. Failure to comply with these precautions violates safety standards and the intended use of the instrument. MICROM International GmbH is not liable for misuse of the instruments and failure to comply with basic safety requirements.

INSTRUMENT GROUNDING

To avoid injury from electrical current, the instrument must be connected with the protective earth. The instrument is equipped with a three wire ground plug. The power outlet must be connected to the protective earth and must meet the International Electrotechnical Commission (IEC) regulations.

CAUTION: MAINS VOLTAGE

Never remove instrument covers during operation. Component replacements as well as adjustments must only be made by trained service personnel. Only use original spare parts for replacement work. Unplug the unit before removing or opening the covers.

DANGER IN EXPLOSIVE ENVIRONMENT

The instrument must not be operated in the presence of flammable gases. Moreover, the instrument must not be exposed to conditions whereby dangerous gas concentrations can occur.

HAZARD OF RADIOACTIVE RADIATION



When working with radioactive specimens observe all applicable radiation safety procedures. When working with radioactive contaminated material, appropriate safety and disinfection measures must be carried out. According to the rules and regulations concerning the handling of radioactive contaminated material of the respective laboratory, safety clothing (e.g. particle mask, gloves, protective shoe covers) must be worn. Radioactive contaminated waste must be disposed of according to the respective regulations.

HAZARD OF INFECTION



Specimens used during the intended operation of the instrument might potentially be infectious. For this reason, it is recommended to observe the general laboratory regulations concerning protection against danger of infection.

Information on decontamination media, their use, dilution and effective range of application can be read in the Laboratory Biosafety Manual : 1984 of the World Health Organization.

When working with infectious specimens observe all applicable safety procedures. When working with infectious material, appropriate safety and disinfection measures must be carried out. According to the rules and regulations concerning the handling of infectious material of the respective laboratory, safety clothing (e.g. particle mask, gloves, protective shoe covers) must be worn. Infectious waste must be disposed of according to the respective regulations.

CARE IN USING MICROTOME KNIFE



To diminish the danger of being injured by the knife or blade, use the knife guard when adjusting specimen and knife. If possible, the specimen should be clamped in before the knife is inserted into the knife holder. Before changing the knife holder, always remove blade or knife! Unused knives should always be kept in a knife case. Never place the knife with the cutting edge upwards. Never try to catch a dropping knife!! Never check the sharpness of the cutting edge with your fingers. The cutting edge is extremely sharp!

HAZARD OF MALFUNCTION

To avoid the hazard of malfunction of an instrument, it must only be operated in a controlled electromagnetic environment. This means that transmitters such as mobile phones must not be operated in their close vicinity.

In case of malfunctions and/or service work, please turn off the instrument and contact your local dealer.

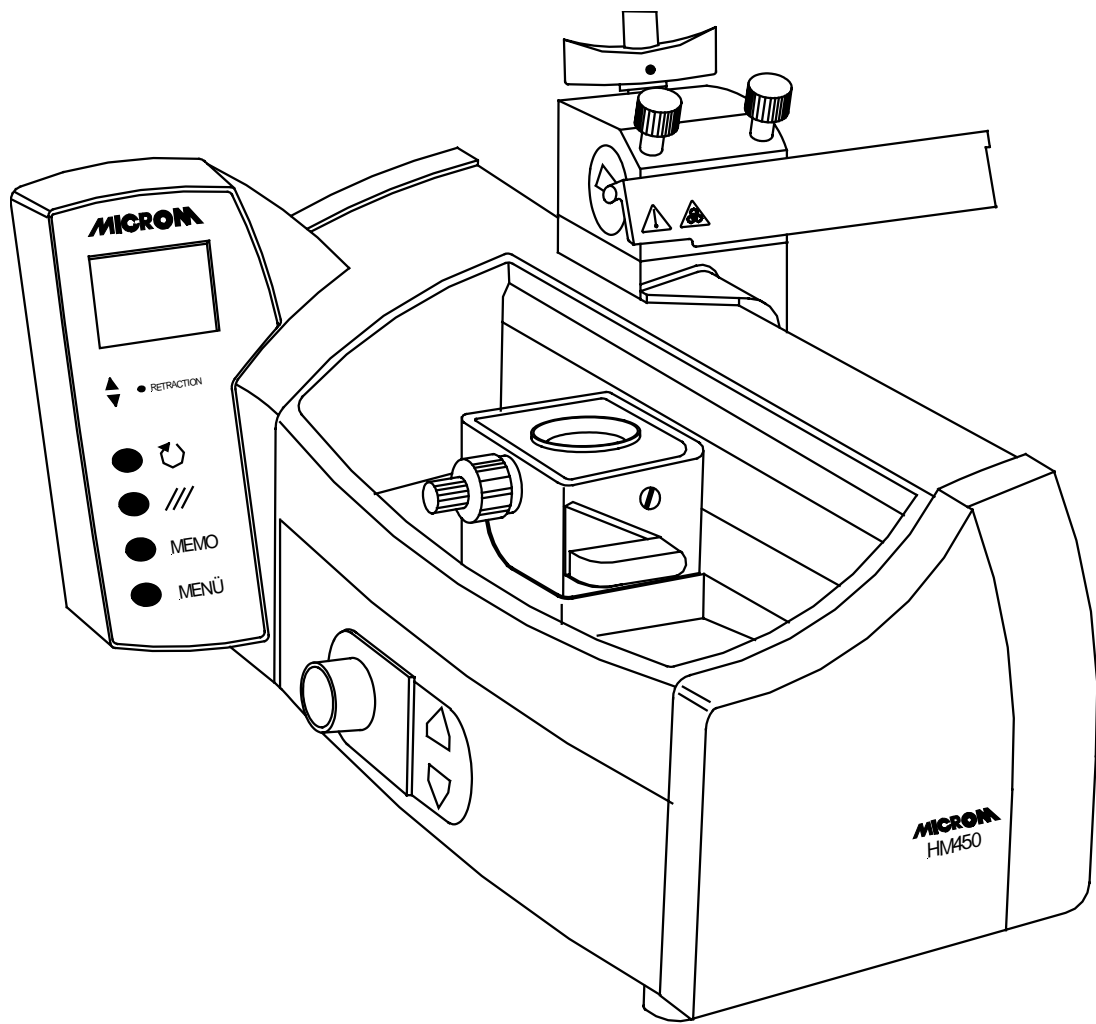

Fig. 1

PART 1 INTRODUCTION

1-1 DESCRIPTION OF THE SLIDING MICROTOME HM 450

The sliding microtome HM 450 from MICROM International GmbH is a highly efficient instrument with specimen retraction during return travel. It can be used for sectioning paraffin in the routine lab. The main applications are in human and veterinary medicine. Moreover, the sliding microtome can be used for the specimen preparation in the medical and industrial research. Large and hard specimens from pharmaceuticals industry or from quality assurance labs can also be sectioned.

The cross roller bearings on sledge and block allow non-tiring working and a smooth sliding movement with optimal stability.

The HM 450 will cut sections from 0 µm to 100 µm. The specimen clamping can be moved up and downwards via the two arrow-shaped coarse feed buttons on the left side of the instrument. This way, specimen and knife edge distance can be adjusted quickly.

The knife carrier is designed so the knives can be easily clamped in place and adjusted.

The coaxial specimen orientation allows orientation with one hand.

1-2

TECHNICAL DATA HM 450

Microtome:	Section thickness range: 0 - 100 µm Resolution:..... 1 µm for 0...10 µm 2 µm for 10...20 µm 5 µm for 20...60 µm 10 µm for 60...100 µm Retract function for compensating thermal extension: 2 µm Trimming section thickness: 10... 500 µm Resolution:..... 10 µm for 10...100 µm 20 µm for ...200 µm 50 µm for 200...500 µm Specimen retraction during return travel 40 µm Vertical feed range 40 mm Horizontal knife stroke 190 mm
Cutting drive: manual sliding movement
Coarse feed:electrical via stepping motor
Feed:automatic via sliding movement or manual via feed button
Specimen size:up to max. 80 x 60 mm
Specimen orientation:	x - and y - axes: univiersal 8°
Transporation- & storage conditions:	
Storage temperature range: -20°C up to +50°C
Operating conditions: +5°C up to +35°C (at a max. rel. humidity of 60%) altitude up to 2000 m M.S.L.for indoor use only Floor loading requirements: 150 kg/m ²
Power requirements: 100 V...240 V/0,5 A/50...60 Hz/+/-10%
Internal protections:	
Secondary circuits:F1 on the power supply unit F 2,5 AH F1 on CPU board T1.0 AH F2 on CPU board T2,0 AH
Primary circuits: 2 x T 0,63 AH
Pollution degree:2
Overvoltage category:II
Sound pressure: 39 dB(A) measured with 1 m distance to the instrument
Dimensions: wide: 370 mm, deep: 460 mm, high: 320 mm
Weight:23 kg

PART 2 OPERATING INSTRUCTIONS

2-1 SETTING UP THE MICROTOME

- Unpack the microtome and remove the wrapping.
- To carry the instrument, lift it on the front and rear side from the lower side.



Warning:

Do not carry the instrument on the handle of the knife sledge!

- Place the instrument on an even surface in a way that the knife guidance is moved towards the user and away from him.
- The coarse feed arrow buttons and the display should show to the left side and the knife carrier handle to the right side.
- Choose the installation site so that the mains switch for separating the instrument from the power supply is accessible at any time.



Note:

Sectioning can be influenced by nearby instruments which generate vibrations. For this reason, the microtome should

be placed on a stable and vibration free table.



Note:

The standard equipment includes four rubber feet which are smaller than the ones that were installed in our factory.

Should the working height be too high when setting up the microtome, unscrew the original feet and replace them with the lower ones.

2-2 INITIAL TURN-ON



Note:

The kind of the used examination materials and all special conditions for their processing, pre-treatment and, if necessary, storage as well as instrument controls for correct and safe operation is in the responsibility of the operator.

The operator is also responsible for special equipment and materials and/or reagents for the operation of the instrument.



Warning:

Before turning on the instrument for the first time, please check if the power requirements indicated on the type plate (fig. 2) correspond to the power supply voltage being used!

- Connect the power cord to the power socket (fig. 3.2) on the rear side of the instrument.
- Turn on the power switch (fig. 3.1).
- Whenever the instrument is turned on, the specimen clamping moves to the lower end position for initialization.
- Here the MICROM logo together with the instrument type is shown.
- Afterwards, FEED and TRIM are shown in the normal display mode.

The insert for the two fuses is placed beside the power switch. (See part 5, Replacing the fuses).

The terms shown on the display are available in German, English and French. If desired, the user can change the language himself.

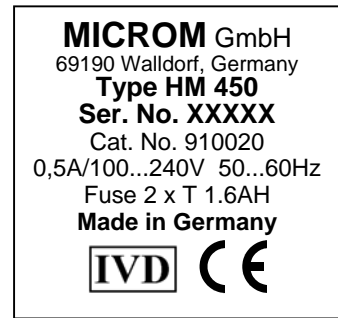

Fig. 2

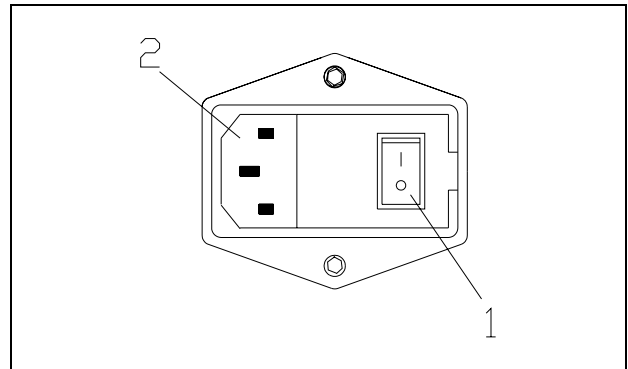

Fig. 3

2-3 CUTTING MOVEMENT AND RETRACTION

- To start the cutting movement of the microtome, move the sledge horizontally.
- The knife (or blade) which is clamped into the knife carrier is drawn horizontally over the specimen towards the user. This way, sections are produced.
- In the front reversal point of the sliding movement, i.e. when the sledge is moved again backwards, the specimen is retracted for the protection of knife and specimen.
- If the function <retraction> is active, this is shown by the message **R:ON** in the normal display mode.
- If desired, the function <retraction> can be turned off.

2-4 LOCKING THE SLEDGE

For the protection against injury by unintended movements of the knife sledge, the microtome is equipped with a lock of the sledge in any position.



Caution:

The sledge should be locked for the user's personal safety, e.g. when new specimens are clamped into position, knives are exchanged, the instrument is cleaned or other adjustment processes are carried out.

- The lock is released via a lever on the rear side of the sledge and is easily accessible from the right side behind the handle.

Locking the sledge:

- Swivel the locking lever from the upper position (fig. 4.1) into the lower position (fig. 4.2).
- For this, the red marked lever surface becomes visible to show the clamped state.

Loosening the sledge:

- Swivel the lever from the lower position (fig. 4.2) into the upper position (fig. 4.1) until the red mark cannot be seen anymore.
- The knife sledge can be moved again.

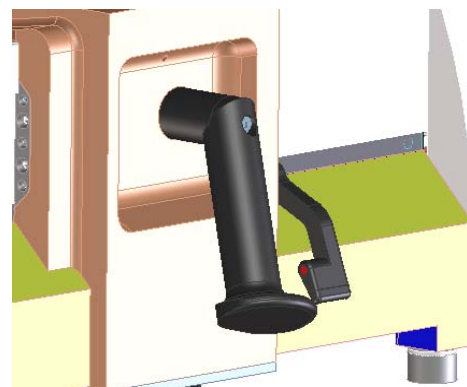
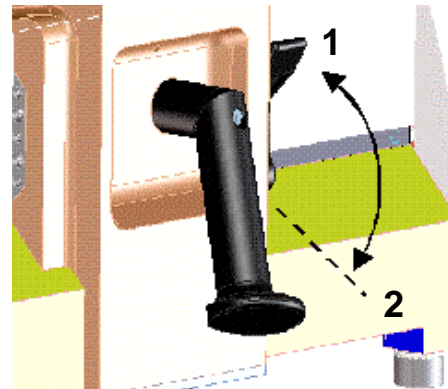

Fig. 4

2-5 SETTING SECTION THICKNESS AND TRIMMING THICKNESS

The required section thickness and trimming thickness is set via the operating knob on the left side of the instrument.

To choose between section thickness and trimming thickness, press the operating knob (fig. 5.1) or the button on the handle. The respective chosen value is now shown with a frame on the display.

When the instrument is turned on again, the values which were chosen when the instrument was turned off, are shown again.

When turning the operating knob, slight resistances can be felt.

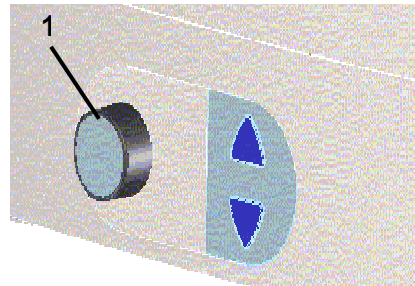

Fig. 5

FEED = selected section thickness
TRIM = selected trimming thickness

The graduation of the section thicknesses is divided into 4 ranges:

range	graduation
from 0 μm to 10 μm	1 μm
from 10 μm to 20 μm	2 μm
from 20 μm to 60 μm	5 μm
from 60 μm to 100 μm	10 μm

The graduation of the trimming thicknesses is divided into 3 ranges:

range	graduation
from 10 μm to 100 μm	10 μm
from 100 μm to 200 μm	20 μm
from 200 μm to 500 μm	50 μm

2-6 SPECIMEN FEED

2-6-1 COARSE FEED AND SPEED FOR COARSE FEED

For the fast up and downward travel between specimen and knife edge, the microtome has a coarse feed with vertical direction.

- The specimen clamping can be moved 40 mm vertically up or downwards via the two coarse feed buttons (fig. 6.1).
- The specimen is moved upwards as long as the arrow-up-button is being pressed.
- To move the specimen downwards, press the arrow-down-button.
- If this button is pressed shorter than one second, the specimen is moved downwards as long as this button is being pressed.
- If this button is pressed for more than one second, the specimen is moved downwards even after releasing the button until lower end position is reached.
- This mode is shown on the operating panel by illuminating the red arrow-down.
- The movement is either automatically stopped when reaching the lower end position or by pressing again one of the two arrow buttons.

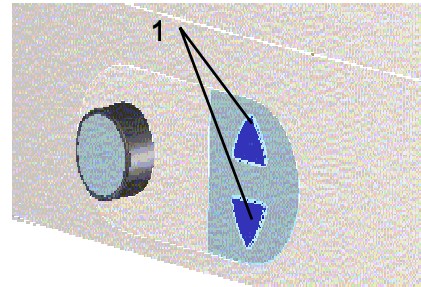

Fig. 6

Warning:



It is not recommended to carry out an exact coarse feed on knife level while the retraction indication lights up. There is the risk to destroy the specimen during the first cuts!

Three different speeds for the coarse feed are available: 400, 700 and 1000 $\mu\text{m/s}$. The three settings are shown on the display by the following symbols:

* = 400 $\mu\text{m/s}$,

** = 700 $\mu\text{m/s}$

*** = 1000 $\mu\text{m/s}$.

2-6-2 TRIMMING AND FIRST CUTS

After the specimen and the knife are adjusted, further gradual feed for trimming can be carried out using the function "trimming". For different sectioning series, deeper layers of the specimen can be reached with the function "trimming".



Warning:

It is not recommended to carry out an exact coarse feed on knife level while the retraction indication lights up. There is the risk to destroy the specimen during the first cuts!

The function "trimming" can be activated by pressing the operating knob or by pressing the button on the handle.

If the instrument is in the manual feed mode, the normal display mode shows MAN.

The trimming thickness, which is actually on the display, is delivered in each rear reversal point of the sliding movement as long as the arrow-up-button is briefly pressed.

If the instrument is in the automatic feed mode, AUT is shown in the lower line of the display.

The actual thickness, which was selected on the operating knob, is delivered in each rear reversal point of the sliding movement.

2-6-3 FINE FEED, MANUAL

After having adjusted knife and specimen as well as having trimmed the specimen, sectioning can be started.

The fine feed can be carried out either manually or automatically. The desired feed mode can be selected via the submenu "Automatic/Manual".

When the manual feed mode is activated, MAN is shown in the lower line of the display.

The manual fine feed is carried out by briefly pressing the arrow-up-button.

To generate sections, move the sledge towards the front.

2-6-4 FINE FEED, AUTOMATIC

When the automatic feed mode is activated, AUT is shown in the lower line of the display.

The feed of the pre-selected section thickness is always automatically carried out in the rear reversal point of the sliding movement, regardless of the position at which the sledge is moved forwards again.



Note:

For optimal sections, always move the sledge together with the knife to the rear side over the entire specimen and

then move it forwards.

2-6-5 RETRACT FUNCTION FOR COMPENSATING THE THERMAL EXTENSION

Normally the ambient air slowly warms up the paraffin specimen which was cooled down before. Due to the rising temperature, the paraffin expands and the achieved sections will be slightly thicker than the pre-selected value.

Especially after longer breaks between the sections, a thermal expansion becomes obvious resulting in a thicker first cut at the same section thickness setting. This thermal expansion of the specimen can be compensated by using the retract function.

- Before starting cutting again, briefly press the arrow-down-button of the coarse feed once.
- The specimen will be moved by 2 µm downwards away from the knife.
- Now normal sectioning processes can be started.

2-7 OPERATING PANEL

The ergonomically shaped operating panel has a large, illuminated graphical display (fig. 7.1) showing clearly the respective operating states and settings.

The two arrow-shaped LEDs (fig. 7.2) blink, when the specimen is just in its upper or lower end position.

Another LED (fig. 7.3) shows that the specimen clamping is just in its retraction while the knife sledge is drawn backwards. (Only if retraction is turned on!)



Warning:

It is not recommended to carry out an exact coarse feed on knife level while the retraction indication lights up. There is the risk to destroy the specimen during the first cuts!

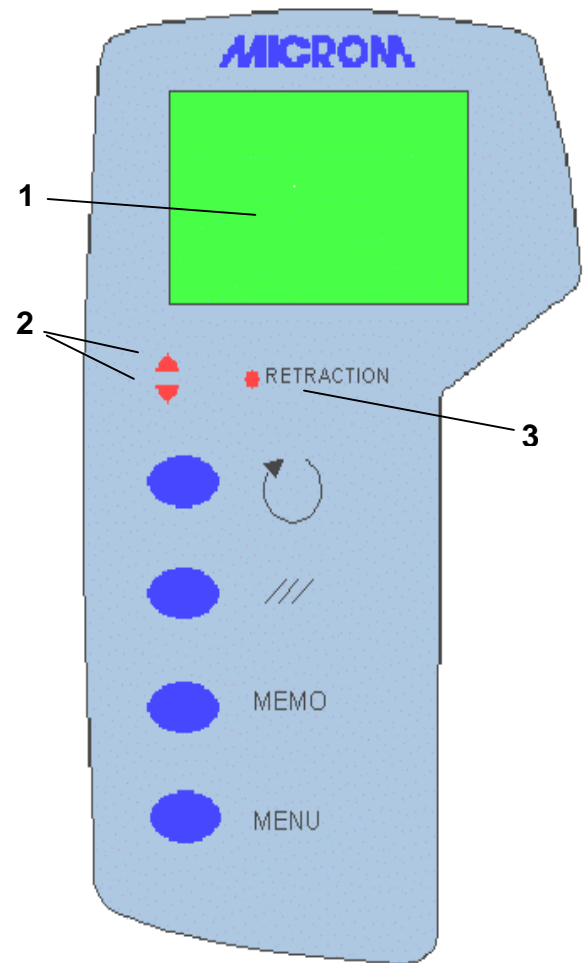

Fig. 7

2-8 KEYBOARD

Below-mentioned the four buttons of the operating panel and their meaning signification on the operating panel are described.

2-8-1 SCROLL BUTTON

Via this button (fig. 8) different information (fig. 9) can be called in the second line on the display:

- current time and date
- number of sections since the last reset
- section thickness sum in μm since the last reset
- available remaining travel in μm
- blank line

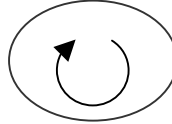

Fig. 8

Time 16:48	28.10.02
COUNTER	235
SUM	23510
REM.TRAV.	14490

Fig. 9

2-8-2 RESET BUTTON

Via this button (fig. 10) the section counter or the section sum can be reset to zero.

- Select the desired number via the scroll button so that it is shown on the display.
- Then press the reset button.
- The number on the display is reset.

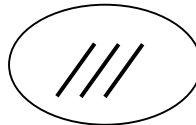

Fig. 10

2-8-3 MEMORY BUTTON

The memory function (fig. 11) is used to rapidly find again a stored first cut position. Pre-condition for this is that blocks are cut which have been embedded in the same mold and always have approximately the same height.



Fig. 11

- To set the first cut position, press the MEMO button longer until "POSITION STORED" is shown on the display.
- Finish sectioning, remove the specimen and clamp in a new one.
- Briefly press the MEMO button to reach the first cut position again rapidly.
- An arrow symbol on the display shows the direction of the movement.
- After having reached the stored first cut position, the coarse feed turns off.
- Fast trimming without time-consuming, gradual feed on the knife is now possible!



Warning:

The stored first cut position can be used effectively when blocks with the same height are cut. Neither adjustments on the knife carrier must be made nor must the knife carrier be moved on the dovetail guide.



Caution:

When changing the knife angle, a new first cut position must be selected as otherwise the danger of a collision with injuries might arise.



Warning:

When turning on the instrument later again, the first cut position must be defined and stored again for safety reasons.

2-8-4 MENU BUTTON

Via the menu button (fig. 12) you have access to further settings which are described below.

- Normally these settings are made when starting to work and do not have to be altered while sectioning.
- In the respective submenus, options can be changed by turning the selection knob to the left side or to the right side and can be confirmed by pressing this knob (ENTER).



Fig. 12

2-8-4-1 Automatic/Manual

Herewith the automatic feed is turned on or off. The options are shown as in the opposite list (fig. 14).



Note:

If the automatic feed is turned on (AUT), a feed of the selected section thickness is delivered when the knife sledge is moved from the return travel into cutting direction.

- Press the menu button. The submenu is shown on the display.
- Select "Process mode" (fig. 13) via the selection knob and confirm it by pressing the knob.
- If the automatic feed is turned off (MAN), briefly press the arrow-up-button to release a manual feed of the selected section thickness.
- The selected mode is permanently shown by AUT or MAN in the normal display mode.



Fig. 13

Automatic/Manual	
Automatic turned on	AUT
Automatic turned off	MAN

Fig. 14

2-8-4-2 RETRACTION ON/OFF

The instrument is equipped with an electronic retraction which can be turned off.

During the return travel of the knife, the specimen is drawn back (away from the knife). This way, the knife does not touch the specimen surface during its return travel.

When the knife movement is reversed for the return travel, the retraction is released without having to pass a certain point. To activate the retraction, just alter the direction.

The retraction process can be heard during each direction alteration by a short click of the stepping motor. It can also be seen via the retraction LED.

- Press the menu button. The submenu (fig. 15) is shown on the display.
- Select "Retraction" via the selection knob and confirm it by pressing this knob.



Fig. 15

RETRACTION	
Retraction turned on	R:ON
Retraction turned off	R:OF

Fig. 16

2-8-4-3 SPEED FOR COARSE FEED

In this menu, the speed for the coarse feed can be selected in three different settings.

- Turn the selection knob to alter the number of the indicated stars (fig. 17). They correspond to the different speeds according to the opposite list (fig. 18).
- Press the selection knob to confirm the indicated setting.



Fig. 17

SPEED FOR COARSE FEED		
Coarse feed speed	400 $\mu\text{m/s}$	*
Coarse feed speed	700 $\mu\text{m/s}$	**
Coarse feed speed	1000 $\mu\text{m/s}$	***

Fig. 18

2-8-4-4 LANGUAGE SELECTION

Here the respective language of the display messages can be selected (fig. 19).

The following languages are available:

- German
- English
- French
- Turn the selection knob and select the desired language.
- Press the selection knob to confirm the desired setting.



Fig. 19

2-8-4-5 SELECTING THE DISPLAY MODE

Here the display mode NORMAL and BIG can be selected (fig. 20).

- The normal display mode (fig. 21) shows the selected feed and trim thicknesses with additional status indications.
- The big display mode (fig. 22) only shows the active section thickness with a large number together with a symbol for the feed or trim thickness range.
- Press the menu button. The submenu is shown on the display.
- Select "Display mode" via the selection knob and confirm it by pressing this knob.
- Return with another press on the menu button.



Fig. 20

NORMAL

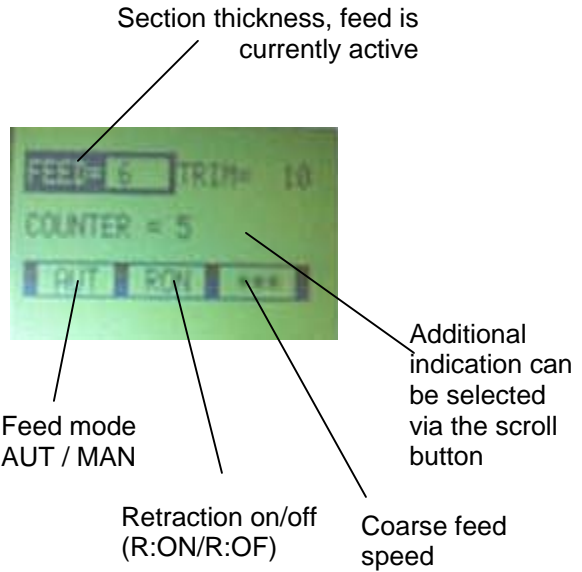
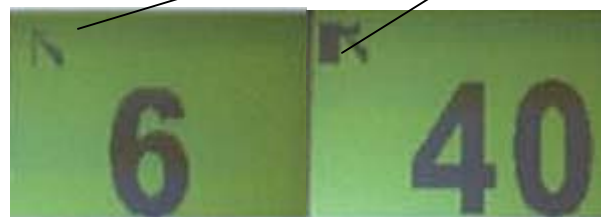

Fig. 21

BIG

Thickness range symbol for fine and trim thickness



Indication of section thicknesses in large numbers

Fig. 22

2-8-4-6 TIME AND DATE

With this menu the current time as well as the current date (fig. 23) can be set.

- Press the menu button. The submenu is shown on the display.
- Select "Time & Date" via the selection knob and confirm the setting by pressing this knob.

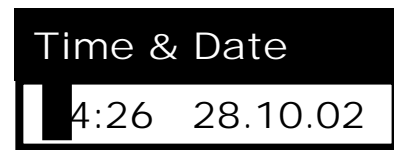

Fig. 23



Note:

In the normal display mode, the current time can be shown constantly via the scroll button.

2-8-4-7 SERVICE MENU

This submenu must only be used by technical personnel which has been trained by MICROM, as it contains diagnostics for error cases.



Caution:

It is not recommended for non-technically trained personnel to use this submenu.

2-9 SPECIMEN CLAMPING

To clamp specimens, different specimen clamping systems are available. With the orienting adapter it is simple to align the specimen properly in relation to the knife.

2-9-1 STANDARD SPECIMEN CLAMP (Cat. no. 715480)

The standard specimen clamp is used for rectangular and square paraffin blocks.

- Insert the specimen on the front fixed jaw (fig. 24.2) and tighten it via the clamping screw (fig. 24.3) with the movable jaw (fig. 24.1).



Warning:

For the stability of the specimen, do not let it project over the clamping jaws too much!

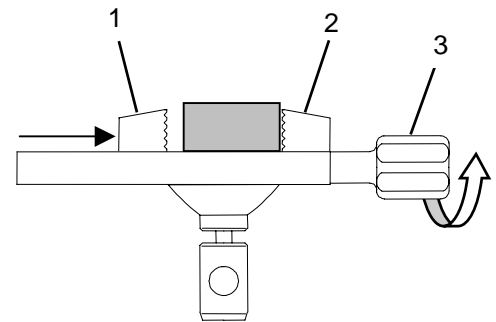

Fig. 24

2-9-2 STANDARD SPECIMEN CLAMP

- This specimen clamp is used in the same way as the above-described standard specimen clamp (see cat. no. 715480).
- The clamping screw and thus the clamping direction of this clamp is arranged transversely in relation to the sectioning direction.
- Specimens with a size up to 45 x 60 mm can be inserted.



Warning:

For the stability of the specimen, do not let it project over the clamping jaws too much!

2-9-3 UNIVERSAL CASSETTE CLAMP (Cat. no. 715500)

The universal cassette clamp represents a quick change system for standardized embedding cassettes.

- To insert or remove cassettes, press the lever (fig. 25.1) upwards.



Warning:

When inserting the universal cassette clamp, please note that the lever (fig. 25.1) is always in parallel alignment with the movement direction of the knife sledge. If the clamp is inserted diagonally in relation to the cutting direction, the feed drive might block!

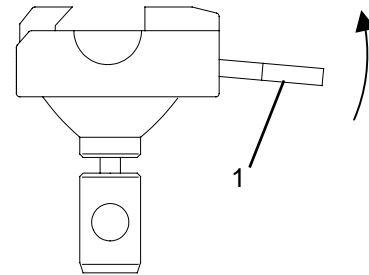

Fig. 25

2-10 CHANGING SPECIMEN CLAMPS

Due to the quick change system of the specimen clampings, specimen clamps can be easily and rapidly changed without needing any tools.

- Loosen the clamping of the specimen clamp (fig. 26.1).
- Set the specimen clamp horizontally by means of the set screws of the orientation device.
- To replace the specimen clamp turn the eccentric lever downwards (fig. 26.1) to the stop and pull it off (fig. 26.2).
- Now the specimen clamp can be removed and replaced with another one.



Note:

Before inserting another clamp, please note the position of the hole in the adapter! It must be aligned in longitudinal direction of the instrument so that the eccentric lever can be pushed in again.

- Again push the eccentric lever into the specimen block.
- Then press the eccentric lever upwards to fix the specimen clamp in position.

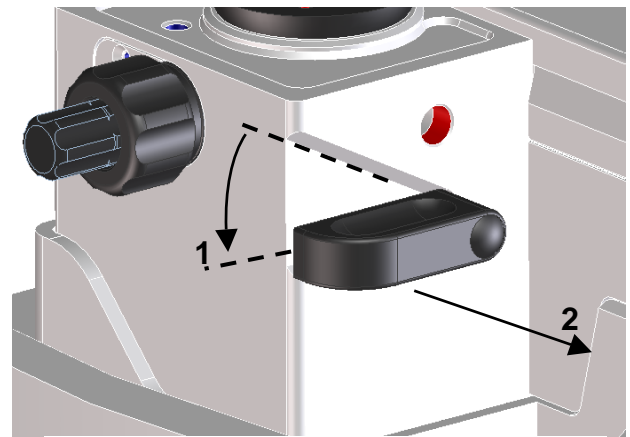

Fig. 26

2-11 KNIFE CARRIER



Hazard of hand injuries:

Due to moving parts in connection also with the microtome knife, a danger area arises, which might lead to hand injuries in case of non-compliance with the safety features of the microtome and when disregarding the instruction manual.

The knife carrier of the microtome is easy to use and equipped with a knife guard for user safety while adjusting knife and specimen.



Caution:

While working on the knife carrier, it should be locked with the sledge locking (see part 2-4).

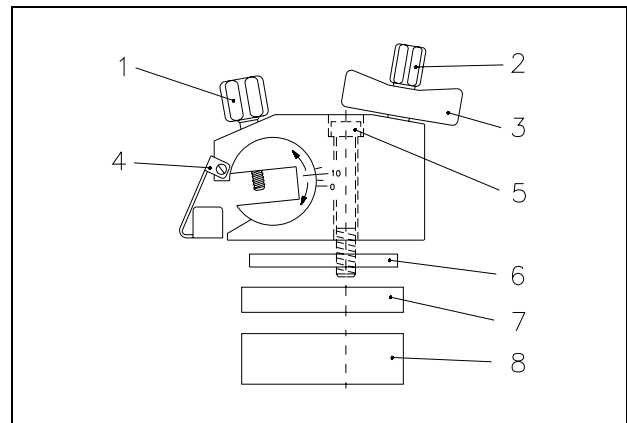

Fig. 27

Inserting the knife

- To insert the knife, slightly unscrew the two clamping screws (fig. 27.1) until the knife can be pushed in from the side.
- Then tighten the two clamping screws to fix the knife in its position.

Clearance angle adjustment

The clearance angle between cutting edge and specimen can be adjusted very easily to the respective requirements of the tissue to be sectioned without loosening the clamping of the knife.

- For this, use the two coaxial screws (fig. 27.2 and 27.3) on the upper side of the knife carrier.
- Loosen the clamping screw (fig. 27.3) in a counter-clockwise direction and adjust the clearance angle by means of the set screw (fig. 27.2).
- The adjusted clearance angle can be read on the scale which is on the right side of the knife carrier.
- Then tighten the screw (fig. 27.3) in clockwise direction to fix the clearance angle.



Note:

By experience, usable cuts are only achieved at a clearance angle of 10° or more.

Protection against injury

- The knife carrier is equipped with a knife guard (fig. 27.4) which should be used while knife or specimen are adjusted.



Caution:

Please note that knives with a length of more than 16 cm (e.g. 22 cm) and/or if it is clamped too much on one side, projects over the knife guard resulting in possible hazards of being injury although the knife guard is used.

Moving the knife sideways

- If the cutting edge of the knife is blunt, loosen the clamping screws (fig. 27.1) and move the knife to the left or right side.
- This process can also be used to protect the knife, as for trimming and fine sectioning different parts of the knife can be used.

Diagonal position of the knife

- After having loosened the central fastening screw of the knife carrier (5) via the attached hex head wrench (size 6), the knife can be adjusted diagonally according to the tissue to be sectioned. This is called "angle cut".
- However, please note that due to the diagonal positioning the usable width of the specimen decreases!

Height adjustment plates (optional)

In case the height adjustment of the specimen block is not sufficient for cutting high specimens, a height adjustment plate can be mounted between knife carrier and sledge.

Height adjustment plates are available with 5 mm, 10 mm and 20 mm.

Knife profile

Knives with profile c and d are available. The opposite figure (fig. 28) shows schematically the angles on the cutting edge profiles of c- and d-knives.

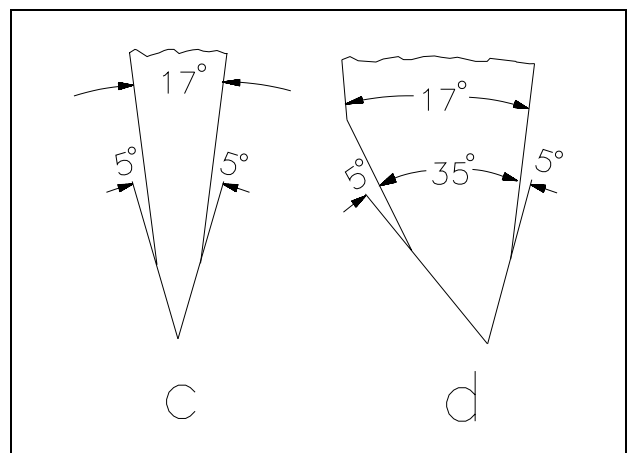

Fig. 28

2-11-1 BLADE HOLDER FOR DISPOSABLE BLADES

Two different types of disposable blades are available: low profile blades (height: 8 mm) and high profile blades (height: 14 mm). When using disposable blades, a blade holder together with a disposable blade is clamped into the knife carrier.

Inserting the blade

- Insert the blade holder into the knife carrier from the left side and tighten the two clamping screws on the knife carrier.
- The clamping lever on the blade holder can be positioned in two ways: 0 = loosened, 1 = clamped.
- To insert the blade, turn the clamping lever to 0.
- Please note that locating and clamping surfaces are clean!!
- To clamp the blade, turn the clamping lever to 1.

Clearance angle adjustment.

- The clearance angle between blade and specimen must be adjusted in the same way as the clearance angle between knife and specimen is adjusted.

Protection against injury

- The knife carrier of the instrument is equipped with a knife guard which can be moved sideways.
- This knife guard should be used while knife and specimen are adjusted.
- This reduces the danger of injury considerably!

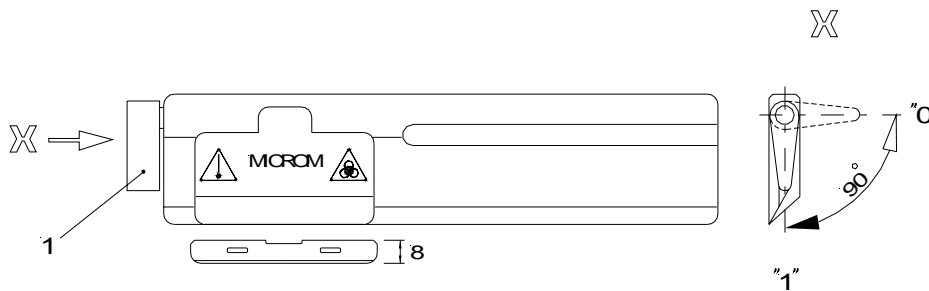

Fig. 29

2-12 STANDARD EQUIPMENT

The microtome HM 450 is supplied with the following accessories:

- 1 hex head wrench 5 mm
- 1 hex head wrench 6 mm
- 1 cover
- 4 rubber feet with lower height
- 1 instruction manual

2-13 ADDITIONAL EQUIPMENT (OPTIONAL)**2-13-1 DISPOSABLE BLADE HOLDER****Cat. no.**

- Blade holder with eccentric fast clamping
- for low profile blades
- for high profile blades

705200
705340

- Case for disposable blade holder
- Cat. no. 705200 and 705340

152160

- Blade holder with Allen key
- for one low profile blade
- for two low profile blades

705430
705440

2-13-2 SPECIMEN CLAMPS

- Universal cassette clamp

715500

- Standard specimen clamp, 45 x 80 mm

715480

2-13-3 HEIGHT ADJUSTMENT PLATES

5 mm	448070
10 mm	440400
20 mm	440410

2-13-4 MICROTOME KNIVES

Steel knives, type c

12 cm	152010
16 cm	152020
18,5 cm	152270
22 cm	152030
25 cm	152040
30 cm	152050

Steel knives, type d

12 cm	152060
16 cm	152070
22 cm	152080
25 cm	152090
30 cm	152100

Tungsten carbide knife 16 cm, d 152120

Knife case

12 cm	152220
16 cm	152230
18,5 cm	152280
22 cm	152240
25 cm	152250
30 cm	152260

Disposable blades for paraffin

EdgeRite low profile blade, 50 pcs. in dispenser 152500

2-13-5 ADDITIONAL ACCESSORIES

Fast freezing unit K 400 (standard specimen clamp is necessary) 770040

Para Gard (paraffin repellent), 100 ml 350170

PART 3 THEORY OF OPERATION

3-1 CUTTING MOVEMENT

The electronic sliding microtome HM 450 has a high-precise, zero-backlash linear roller bearing (cross roller bearing) for the bearing of the knife sledge and the block

These cross roller bearings allow a zero-backlash feed of the knife sledge.

The knife sledge cannot be removed from the user, however, it is restricted guided and always remains on the instrument.

The cutting movement of the microtome is generated by horizontally moving the sledge in the cross roller bearings. Here the knife, which is clamped into the knife carrier, is horizontally drawn over the specimen towards the user and away from him. This way, sections are produced. After having moved the knife sledge backwards into the rear end position, a pre-selected section thickness is carried out either manually by pressing a button or automatically due to the alteration of the direction of the knife sledge. The specimen is delivered towards the knife with the pre-selected section thickness in vertical direction and a new section is produced.

3-2 SPECIMEN COARSE FEED AND TRIMMING FUNCTION

After changing the specimen or moving the knife or knife carrier, it is necessary to adjust the specimen to the knife edge again. This can easily be done by means of the specimen coarse feed and the defined trimming values.

After the specimen and the knife are adjusted, further gradual feed for trimming can be carried out.

3-3 SPECIMEN CLAMPING SYSTEM AND SPECIMEN ORIENTATION

According to the form and size of the specimens, different specimen clamping systems are available to carry the specimen. It is very easy to align the specimen to the knife, using the orienting adapter.

3-4 KNIFE CARRIER

The knife carrier is easy to use and allows the microtome knives to be clamped and adjusted as needed. Depending on application, knives or disposable blades can be used.

3-5 MICROTOME WITH FAST FREEZING UNIT

The fast freezing unit K 400 allows frozen sectioning with the specimen temperature as low as -45°C.

PART 4 WORKING WITH THE MICROTOME

4-1 PREPARATION AND ORIENTATION

Before sectioning, the specimens must be prepared appropriately and embedded in suitable media. Cassettes as well as different forms for round and rectangular specimens can be used for embedding.

With the orienting adapter, the specimen can easily be oriented to the knife.

4-2 COARSE FEED AND TRIMMING FUNCTION

To adjust approximately the space between specimen and cutting edge, use the coarse feed or the trimming function. Continue this to start trimming the specimen, thus achieving the level of interest. Any waste should be wiped away in a forward direction with a brush.

4-3 SECTIONING INSTRUCTIONS



Hazard of hand injuries:

Due to moving parts in connection also with the microtome knife, a danger area arises, which might lead to hand injuries in case of non-compliance with the safety features of the microtome and when disregarding the instruction manual.

To cut usable sections, the following points are of utmost importance:

4-3-1 CONDITION OF THE KNIFE EDGE

Only use a sharp knife! If the knife edge is blunt, move the knife horizontally either to the right or left side to continue working with the sharp area of the cutting edge, or have the knife resharpened.

4-3-2 CLEAN KNIFE SURFACES

For optimal sectioning, front and back of the knife must be clean. Especially, paraffin waste must be removed thoroughly!!

4-4 HOW TO AVOID MALFUNCTIONS



Note:

In case of malfunctions and/or service work, please turn off the instrument and contact your local dealer.

4-4-1 PREPARATION OF THE SPECIMEN

When preparing specimens, be sure that a suitable embedding medium, fixation, dehydration and infiltration time are chosen.

4-4-2 TEMPERATURE OF THE SPECIMEN

Sectioning is carried out at ambient temperature (excluding frozen sections). If the temperature is too high, the paraffin softens. Therefore, avoid heating paraffin specimens by direct exposure to sunlight or other near sources of heat.

4-4-3 TIGHTENING THE CLAMPING SCREWS

Tighten all clamping screws and clamping levers on the knife carrier, specimen holder and specimen orientation.

4-4-4 SELECTION OF THE KNIFE

Carefully select the required knife material and profile.

4-4-5 ADJUSTMENT OF THE KNIFE

Take care to adjust the proper clearance angle of the knife.

Select a clearance angle adjustment of 10° or more according to the facet angle.

4-4-6 CUTTING SPEED

Take care to select proper cutting speed.

General Rule: The harder the material, the slower the cutting speed!!

4-4-7 TRIMMING

Take care in bringing the knife and specimen together.

PART 5 MAINTENANCE

Annual routine maintenance

To secure section quality and functioning of the microtome, it is recommended that a **routine maintenance** be performed by a trained service technician **once a year**.

Service contract

MICROM offers a service contract which guarantees that your instrument is always in perfect condition. For more information, please contact the nearest MICROM sales office.

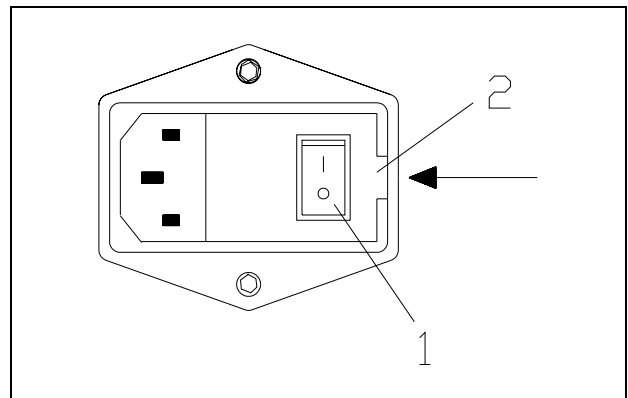

Fig. 30

EXCHANGE OF FUSES

The two mains fuses are installed on the back of the instrument beside the power switch (fig. 30.1).

- To exchange the two fuses, turn off the power switch of the instrument and unplug the instrument.
- Open the small cover (fig. 30.2) of the fuse holders from the right side (see arrow) by means of a flat screw driver.
- Pull out the fuse holders, each of which is marked with an arrow and exchange the fuses against new ones.

Rating of fuses:

For power requirements 100 - 240 V:

2 x T 1.6 AH

PART 6 CLEANING AND CARE

Cleaning intervals

Cleaning, care and decontamination of the microtome depends on how frequently the microtome is used. For optimal sectioning, the instrument must be free of section waste, especially the guides and clamping mechanism.

Cleaning agents

Mild household cleaners can be used to clean the microtome. Do not use aggressive cleaners or solvents, as the paint and plastic parts can be affected.



Note:

Before starting cutting, instrument, knife carrier and section waste trays should be treated with a commercially available paraffin repellent, e.g. Para Gard.

Care

- Remove the knife from the knife carrier.
- Clean it with a dry cloth to avoid the formation of rust and keep it in a knife case.



Caution:

Never put the knife with the cutting edge upwards on the table!

- Clean the operating controls and the surfaces of the knife carrier, especially the space where the knife is installed.
- The maintenance-free cross roller bearings are covered and protected against dust and section waste and need not to be lubricated or cleaned by the customer.
- Clean the specimen clamping system, specimen orientation, housing and vertical carrier.

PART 7 CONDITIONS FOR THE TRANSPORTATION OF THE INSTRUMENT

7-1 TAKING BACK THE INSTRUMENT FOR REPAIR OR ROUTINE MAINTENANCE

Repair or maintenance work are normally carried out at the site of installation. If this is not possible for some special reasons, the instrument can be returned to MICROM. The contact address can be found at the beginning of this instruction manual.

- To guarantee trouble-free function of the instrument after transportation, please note the below-mentioned measures for the transportation preparation.
- In addition, the conditions for storage and transportation as mentioned in part 1-2 must be observed during the entire transportation.

Biohazard:



Please also note the precautionary measures described in our safety precautions concerning biological hazards!

Measures for closing down:

- Turn off the instrument.
- Unplug the unit.
- Remove knife or blade and store it in a safe way.
- Secure the sledge via the lock of the sledge as described in part 2-4.



Note:

The locking of the sledge functions as a brake. In case the instrument is kept in an inclined way, the braking power might not be sufficient enough to avoid that the sledge moves.

- To lift the instrument, take it on each fore-parts. During transportation, do not carry the instrument on the handle. Danger of injury!

For transportation outside closed buildings, please observe the following additional measures:

- Turn off the instrument.
- Unplug the unit.
- Remove knife or blade and store it in a safe way.
- Secure the sledge via the transportation safety sheet: Place the sheet onto the specimen holder. Move the sledge into a position so that the holes correspond with each other and tighten the screws.



Note:

The locking of the sledge is functions as a brake. In case the instrument is kept in an inclined way, the braking power might not be sufficient enough to avoid that the sledge moves.

- To lift the instrument, take it on each fore-parts. During transportation, do not carry the instrument on the handle. Danger of injury!
- Pack the instrument into the original packing as it offers best pre-conditions for transportation without damage.



Note:

If the original packing is no longer available, please contact your local MICROM representation.

7-2 DISPOSAL OF THE INSTRUMENT AFTER FINAL SHUTDOWN

After the final shutdown of the instrument, we recommend to contact a local recycling company for the disposal according to the national applicable regulations.



To be applied in the countries of the European Union and other European countries with a separate collecting system within the waste management.

The marking of the product and/or the respective literature indicates that, after its final shutdown, it must not be disposed of together with ordinary domestic waste.

- Please dispose of your instrument separately from other waste to not harm our environment and/or human health by uncontrolled waste disposal.
- Recycle your instrument to support the sustainable recycling of material resources.
- **Industrial users** should contact their suppliers and observe the conditions of the contract. This product must not be disposed of together with other commercial waste.
- **Please contact your supplier!!**