

**MICROTOME CRYOSTAT**

**HM 520**

**INSTRUCTION MANUAL**



**CERTIFICATION**

MICROM International GmbH certifies that this instrument has been tested and checked carefully. Its technical data was verified before shipment to be in accordance with the published specifications.

The instrument complies with applicable international safety regulations.

**WARRANTY**

This MICROM product is warranted against defects in material and workmanship for a period of 1 year. Parts which prove to be defective during the warranty period will be repaired or replaced free of charge by MICROM International GmbH. No other warranty is expressed or implied. Unauthorized modification or repair by third party persons will void the warranty.

The warranty will expire in case of improper or wrong use of the instrument and in case the warning and precautionary messages are not observed. MICROM International GmbH is not liable for any occurring damage.

Errors and omissions excepted. Subject to amendment and improvement without further notice.

This instruction manual will be supplied together with each instrument. Further copies can be ordered at the nearest MICROM sales office by giving the serial number of the instrument, the number of the instruction manual and the date of issue.

This instruction manual is available in the following languages:

	Cat. No.
German:	387771
English:	387772
French:	387773
Spanish:	387774



**INTENDED USE**

*Dear Customer,*

Before putting the instrument into operation, please read these operating instructions carefully to familiarize yourself with its proper operation and functions.

The MICROM cryostat HM 520 is a highly efficient cryostat for sectioning techniques in routine and research.

Only skilled or specially trained personnel must operate the microtome cryostat, i.e. placing the specimen onto a chuck, sectioning and transferring sections onto a slide. The listed and marked safety measures as well as the regulations and hygiene measures of your respective lab must strictly be observed.

---

---

MICROM Ser. No. :.....

Please check the MICROM Ser. No. on the type plate, which is placed on the rear side of your instrument and enter this number here. This way, questions and service can be handled faster.

Instruction Manual No. 387772

Issued on February 10, 2006

MICROM International GmbH Robert-Bosch-Strasse 49
--

D-69190 Walldorf
------------------

Telefon: (06227) 836-0 Telefax: (06227) 836-111
--

**Intended Use****Table of Contents****EC Certificate of Conformity****Safety Precautions****PART 1 INTRODUCTION**

1-1 Description of the HM 520

1-2 Technical data HM 520

**PART 2 OPERATING INSTRUCTIONS**

2-1 Setting up the cryostat

2-2 Initial turn-on

2-3 Basic operational rules

2-3-1 Actual and set value of the chamber temperature

2-3-2 Defrosting the evaporator

2-3-3 Interrupting a defrosting cycle

2-3-4 Emptying the defrosting liquid

2-3-5 Illumination of the cryo chamber

2-3-6 Freezing on a specimen

2-3-7 Heat extractors (optional accessories)

2-3-8 Specimen orientation with zero positioning

2-3-9 Handwheel lock

2-4 Cutting process

2-4-1 Cutting movement and retraction

2-4-2 Setting section thickness and trimming thickness

2-5 Feed

2-5-1 Specimen coarse feed

2-5-2 Memory function

2-5-3 Trimming and first cuts

2-5-4 Fine feed

2-6 Indication of cutting processes

2-6-1 Section counter

2-6-2 Sum of section thicknesses

2-6-3 Remaining travel to front end position

2-6-4 Setting the real time

2-7 Knife carriers

2-7-1 Standard knife carrier

2-7-2 Disposable blade carrier

2-7-3 Disposable blade carrier EC 70

- 2-8 Error code indication
- 2-8-1 Definition of the error codes

- 2-9 Accessories
- 2-9-1 Standard equipment
- 2-9-2 Additional equipment

### **PART 3 THEORY OF OPERATION**

- 3-1 Microtome cooling, defrost cycle
- 3-2 Cutting movement
- 3-3 Specimen coarse feed and trimming stages

### **PART 4 WORKING WITH THE CRYOSTAT**

- 4-1 Preparations on the microtome and inside the cooling chamber
- 4-2 Freezing on the specimen
- 4-3 Orientation and trimming of specimens
- 4-4 Temperature list for cryo sectioning
- 4-5 Sectioning and taking off sections
- 4-6 How to avoid malfunctions
- 4-6-1 Possible sources of errors – cause and removal

### **PART 5 MAINTENANCE AND CARE OF THE CRYOSTAT**

- 5-1 Shutting-off for cleaning
- 5-2 Removing the microtome
- 5-3 Cleaning and care of the microtome
- 5-4 Cleaning the cooling lamella

### **PART 6 CONDITIONS FOR THE TRANSPORTATION OF THE INSTRUMENT**

- 6-1 Taking back the instrument for repair or routine maintenance
- 6-2 Disposal of the instrument after final shutdown

# EC Certificate of Conformity

**Name and address of the manufacturer:** MICROM International GmbH  
Robert-Bosch-Straße 49  
D-69190 Walldorf

**Product designation:** Microtome Cryostat  
**Type reference:** HM 520

**Notification to Competent Authorities:**

These medical device have been registered with the German authority as "Microtomes" under the EDMA-classification code: 23-06-02

The designated product complies with the laid down regulation:

**DIRECTIVE 98/79/EC OF THE EUROPEAN PARLIAMENT AND OF THE COUNCIL  
of 27 October 1998  
on in vitro diagnostic medical devices**

The designated product complies with the EC regulations by strictly observing the following norms:

**DIN EN ISO 14971:2001-03**

Medical devices - Application of risk management to medical devices (ISO 14971:2000).

**DIN EN 61010-1:2002-08**

Safety requirements for electrical equipment for measurement, control and laboratory use - Part 1: General requirements (IEC 61010-1:2001).

**DIN EN 61010-2-101:2003-09**

Safety requirements for electrical equipment for measurement, control and laboratory use - Part 2-101: Particular requirements for In-Vitro-Diagnostic-(IVD)-Medical instruments.

**DIN EN 61326:2002-03**

Electrical equipment for measurement, control and laboratory use - EMC requirements (IEC 61326-1:1997 + A1:1998 + A2:2000); German version EN 61326:1997 + A1:1998 + A2:2001

**DIN EN ISO 9001:2000**

Quality management systems - Requirements (ISO 9001:2000)



---

Hans Heid  
Managing Director

Walldorf, 10 February 2004

## SAFETY PRECAUTIONS

### WARNING SIGNALS AND SYMBOLS

The installation and routine use of the HM 520 is easy and safe if the instructions in this manual are being observed.



**Note:**

Special instructions regarding operation of the instrument.



**Warning:**

Special precautionary measures to prevent damage to equipment. For a long lifetime of the equipment, please observe these instructions carefully.



**Caution – general danger spot:**

The instruction manual must strictly be observed whenever this symbol is visible on the instrument.



**Biohazard:**

Warning of biological danger.



**Radioactivity:**

Warning of radioactive danger.



**Separate taking back of electrical and electronic instruments in the countries of the European Union:**

This is to be applied in the countries of the European Union and other European countries with a separate collecting system within the waste management.

This product, being an electro and/or electronic instrument, must be treated separately within the waste management process (WEEE).

**CAUTION!**

The operator's safety is affected, when the instrument is not operated in accordance with this instruction manual.

Please observe the following general precautions during operation of this instrument. Failure to comply with these precautions violates safety standards and the intended use of the instrument. MICROM International GmbH is not liable for misuse of the instruments and failure to comply with basic safety requirements.

**INSTRUMENT GROUNDING**

To avoid injury from electrical current, the instrument must be connected with the protective earth. The instrument is equipped with a three wire ground plug. The power outlet must be connected to the protective earth and must meet the International Electrotechnical Commission (IEC) regulations.

**CAUTION: MAINS VOLTAGE**

Never remove instrument covers during operation. Component replacements as well as adjustments must only be made by trained service personnel. Unplug the unit before removing or opening the covers.

**DANGER IN EXPLOSIVE ENVIRONMENT**

The instrument must not be operated in the presence of flammable gases.

**HAZARD OF FROSTBITE**

Avoid permanent touching of metal parts inside the cryostat microtome chamber as frostbite may occur at unprotected hands and arms.

**HAZARD OF RADIOACTIVE RADIATION**

When working with radioactive specimens observe all applicable radiation safety procedures. When working with radioactive contaminated material, appropriate safety and disinfection measures must be carried out. According to the rules and regulations concerning the handling of radioactive contaminated material of the respective laboratory, safety clothing (e.g. particle mask, gloves, protective shoe covers) must be worn. Radioactive contaminated waste must be disposed of according to the respective regulations.

**HAZARD OF INFECTION**

Use the appropriate safety and disinfection measures when working with infectious specimens. According to the rules and regulations concerning the handling of infectious/radioactive contaminated material of the respective laboratory, safety clothing (e.g. particle mask, gloves, protective shoe covers) must be worn.

**HAZARD OF BIOLOGICAL DANGER**

Specimens used during the intended operation of the instrument might potentially be infectious. For this reason, it is recommended to observe the general laboratory regulations concerning protection against danger of infection.

Information on decontamination media, their use, dilution and effective range of application can be read in the Laboratory Biosafety Manual : 1984 of the World Health Organization.

**HAZARD OF MALFUNCTION**

To avoid the hazard of malfunction of an instrument, it must only be operated in a controlled electromagnetic environment. This means, that transmitters such as mobile phones must not be operated in their close vicinity.

In case of malfunctions and/or service work, please turn off the instrument and contact your local dealer.

**CARE IN USING MICROTOME KNIFE**

To diminish the danger of being injured by the knife or blade, use the knife guard when adjusting specimen and knife. If possible, the specimen should be clamped in before the knife is inserted into the knife holder. Before changing the knife holder, always remove blade or knife! Unused knives should always be kept in a knife case. Never place the knife with the cutting edge upwards. Never try to catch a dropping knife!! Never check the sharpness of the cutting edge with your fingers. The cutting edge is extremely sharp!

**WASTE DISPOSAL**

All debris, waste, defrosting liquid as well as infectious and radioactive contaminated material from operation must be disposed of in accordance with the respective regulations of the lab. Disinfection and cleaning liquids as well as section waste must be disposed of according to the respective regulations for special waste!

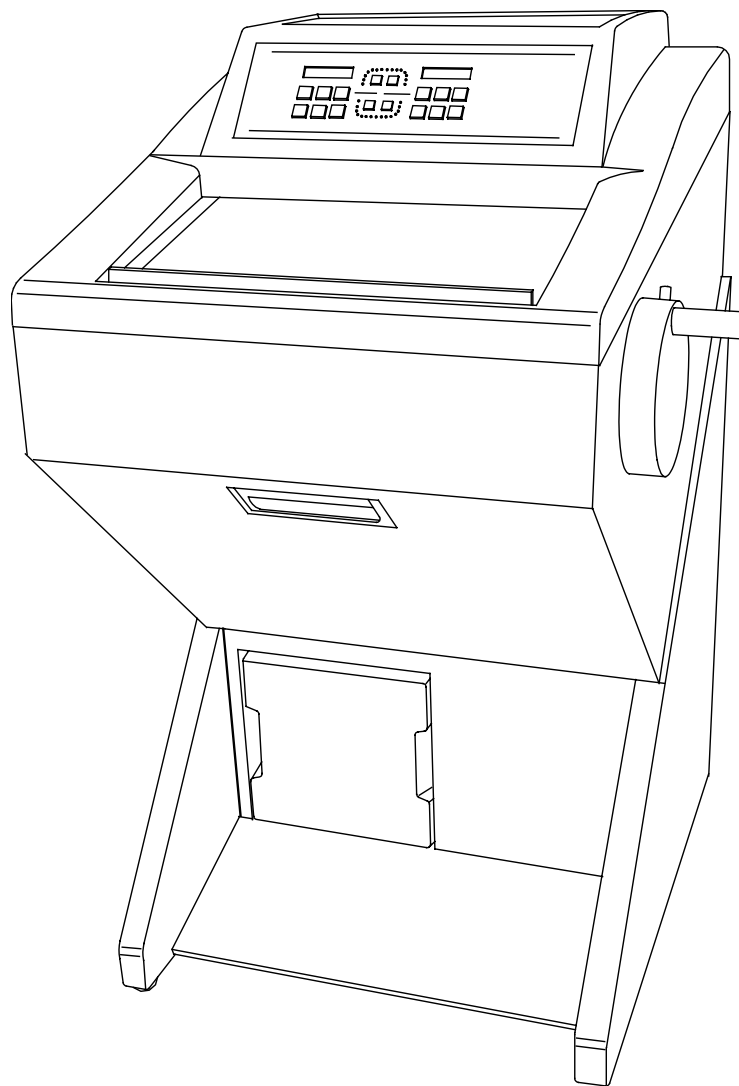

Fig. 1

---

## 1 INTRODUCTION

---

### 1-1 DESCRIPTION OF THE HM 520

Open top cryostat. Stainless steel cooling chamber. Chamber temperature regulation variable from +5°C down to -30°C.

Graphic LED-display of set and actual temperatures, electronic control with user-oriented touchpad keyboard, battery-buffered memory and self-diagnostic system.

Automatic defrosting and in addition a manual defrost cycle which can be activated when needed. Defrost interrupt on keystroke request.

Integrated fast freezing device down to -35°C. Sliding window with heater. Integrated fluorescent lamp for cryo-chamber. Brush shelf and storage space inside the cryo chamber. Large, flat storage space on top of the housing with integrated storage space for marked slides.

Rotary Microtome with backlash and maintenance-free cross roller bearings in stainless steel. Electro-mechanical feed system.

Section thickness setting from 2 to 22 microns;  
up to 10 µm in 1 µm-increments,  
up to 22 µm in 2 µm-increments,

Trimming thickness setting from 10 to 500 microns;

up to 100 µm in 10 µm-increments,  
up to 300 µm in 50 µm increments and  
up to 500 µm in 100 µm-increments.

Specimen retraction during the return stroke with optical indication. Horizontal feed range 28 mm. Vertical cutting stroke 60 mm.

Max. specimen size 70 x 55 mm.

Motorized coarse feed in two directions.

Limit indication and automated switch off at front and rear limits of horizontal travel.

Section counter and indication of sum of section thicknesses with reset-button. Indication of remaining travel.

Mechanical handwheel brake in the lower reversal point of the specimen orientation.

Fine orientation of specimen 8° universally in x/y-axis with zero device. Rotatable on Z-axis, 360°.

Basic outfit with six specimen chucks, 118 ml MICROM freezing medium, 100 ml cryostat oil, brush shelf and section waste tray, consisting of two parts.

**1-2**

**TECHNICAL DATA HM 520**

Chamber temperature control:.....+5°C to -30°C  
 Fast freezing station depending on the chamber temperature:.....down to -35°C

Defrosting:                      automatic defrosting, adjustable .....with temperature control  
   manual immediate defrosting

Microtome:                      Section thickness range: ..... 2 - 500 µm

Fine section thickness range:..... 2 - 22 µm

Resolution: ..... 1 µm for 2 - 10 µm

..... 2 µm for 10 - 22 µm

Trimming thickness range: ..... 10 - 500 µm

Resolution: ..... 10 µm for 10 - 100 µm

..... 50 µm for 100 - 300 µm

..... 100 µm for 300 - 500 µm

Specimen retraction during return travel .....40 µm

Vertical specimen stroke ..... 60 mm

Horizontal specimen movement.....28 mm

Read-outs:                      Five-digit LED-display: section thicknesses, section counter, sum of  
 section thicknesses, remaining travel to front end position and  
 chamber temperature

Coarse feed:                      ..... motorized, graduated, single and continuous

Size of chucks:                      .....30, 40 mm

..... special sizes upon request

Specimen orientation:            x - and y - axes: ..... universal 8° with zero positioning

z - axis: ..... up to 360°

Cooling chamber illumination

Sliding window

Cutting drive:                      ..... manually via handwheel

Cutting area:                      ..... horizontal specimen movement 28 mm

.....vertical specimen stroke 60 mm

*All temperatures refer to an ambient temperature of +20°C!*

Cont'd on page -2-

**1-2 TECHNICAL DATA HM 520**

Handwheel brake: ..... mechanical

Transportation and storage conditions

Storage temperature range: ..... -20°C up to +50°C

Operating conditions: ..... +5°C up to +35°C (at a max. rel. humidity of 60%)  
 ..... altitude up to 2000 m M.S.L.  
 ..... for indoor use only  
 ..... Floor loading requirements: 230 kg/m<sup>2</sup>

Power requirements: ..... 100 V/50 Hz, 12 A, +/-10%  
 ..... 100 V/60 Hz, 12 A, +/-10%  
 ..... 115 V/60 Hz, 12 A, +/-10%  
 ..... 220...230 V/50 Hz, 6 A, +/-10%  
 ..... 220 V/60 Hz, 6 A, +/-10%  
 ..... 240 V/50 Hz, 6 A, +/-10%

Internal protection

Primary circuits:

Transformer: ..... T5.0AH, 100...115 V  
 ..... T2.5AH, 220...240 V

Illumination: ..... T0,8AH, 100...115 V  
 ..... T0,4AH, 220...240 V

Secondary circuits:

Window heating: ..... T2,5AH  
 CPU: ..... 11 VAC/T0.5AH  
 Panel: ..... 11 VAC/T0.5AH  
 Stepping motor/valve: ..... 24 VAC/T2.5AH

Pollution degree: ..... 2  
 Overvoltage category: ..... II  
 Sound pressure: ..... 45 dB(A)  
 ..... measured with 1 m distance to the instrument

Fluids and gases: ..... cooling agent: R404a, filling amount: 235 g

Dimensions: . Wide (w/o handwheel): 640 mm, deep: 760 mm, high: 1200 mm

Weight: ..... 143 kg (depending on the model)

*All temperatures refer to an ambient temperature of +20°C!*

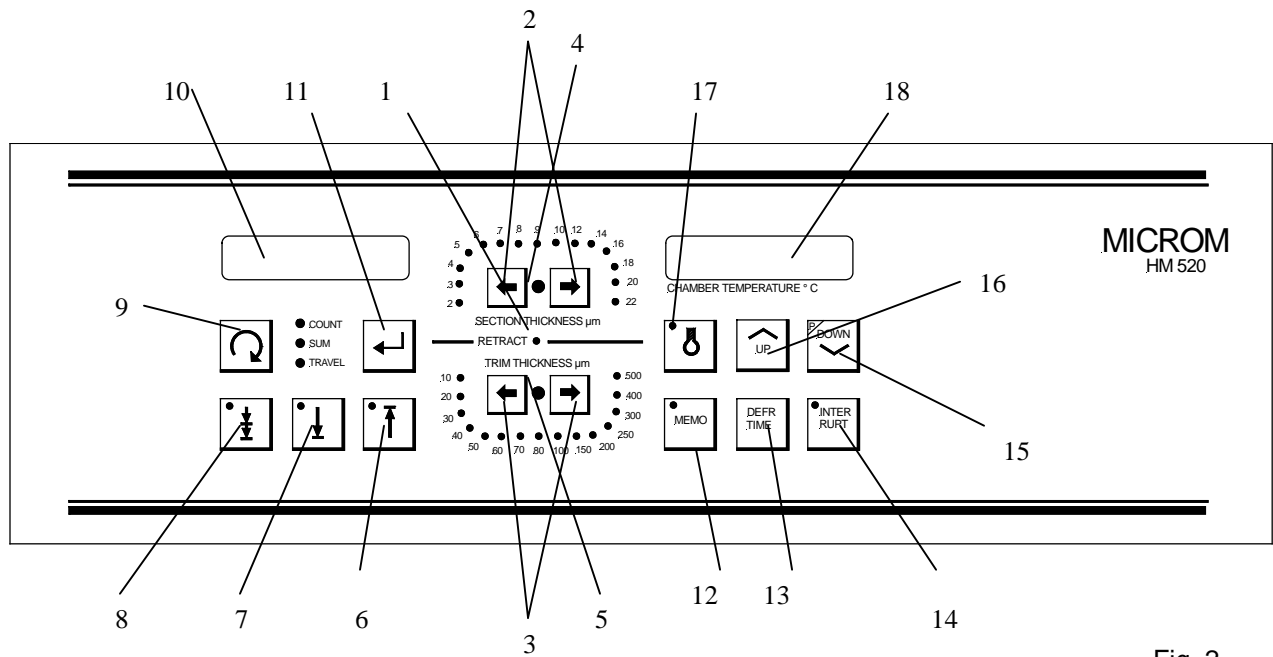

Fig. 2

- |                                |                                    |
|--------------------------------|------------------------------------|
| 1 = LED retraction             | 10 = Display, left                 |
| 2 = Section thickness setting  | 11 = Reset button                  |
| 3 = Trimming thickness setting | 12 = Memory button                 |
| 4 = LED fine feed              | 13 = Setting defrost time          |
| 5 = LED trim feed              | 14 = Interruption defrosting cycle |
| 6 = Coarse feed, backwards     | 15 = Down button                   |
| 7 = Coarse feed, forwards      | 16 = Up button                     |
| 8 = Trim button                | 17 = Chamber illumination          |
| 9 = Scroll button              | 18 = Display, right                |

## 2 OPERATING INSTRUCTIONS

### 2-1 SETTING UP THE CRYOSTAT

#### Unpacking the instrument:

- Cut through the three packing straps and remove the packing.
- Remove the upper wooden cover (fig. 3.1).
- The hinges of the upper wooden cover are secured with tape.
- Remove this tape.
- Lift the packing (fig. 3.2) over the instrument.
- Remove the upper and lower supporting foams (fig. 3.3, 3.4, 3.5, 3.6) from the cryostat.



#### Note:

The upper wooden cover now serves as an incline (fig. 3a.1) on which the cryostat can be moved from the pallet to the floor by using the handle (fig. 3a.2)

- The hinges of the upper wooden cover (fig. 3.1) are inserted into the screws of the bottom plate (fig. 3a.3). The correct side for this is marked with arrows.
- The tool (fig. 3b.2, size 30) for the height adjustment of the setting feet of the cryostat is packed together with the accessories of the cryostat (separate carton on the foot rest of the cryostat).
- Turn the setting feet completely upwards via this tool so that the cryostat stands with its rollers on the bottom plate (fig. 3a.3).
- Via the handle (fig. 3a.2) roll the cryostat from the bottom plate (fig. 3a.3) over the wooden cover (fig. 3a.1). In doing so, the rear side of the instrument must show to the incline (fig. 3a.1).

#### Caution:



The instrument is very heavy. While the instrument rolls down on the incline, it must be guaranteed that the instrument does not move in an uncontrolled way.

- Now the cryostat can be rolled to its site of installation.
- For possible return shipments, please keep the packing.

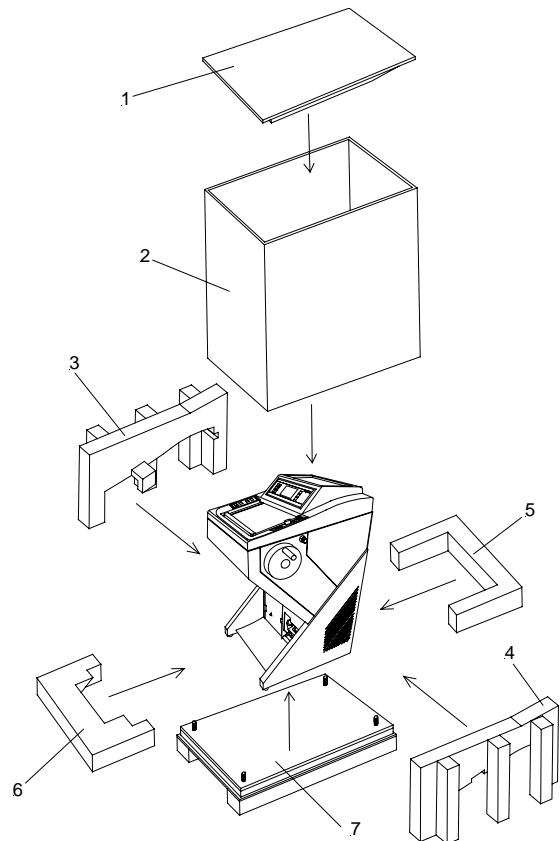

Fig. 3

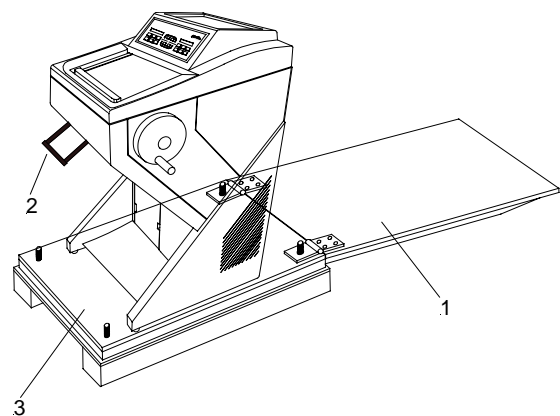

Fig. 3a

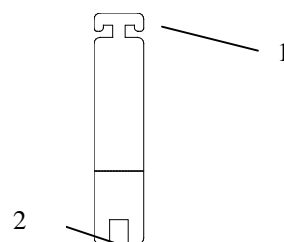

Fig. 3b



**Warning:**

The instrument must only be moved in standing or slightly tilted (approx. 30°) position.

**Choose installation site that**

- enough ventilation for the cooling system is guaranteed.
- the distance between wall and rear panel is approx. 15 cm. For this, install the distance bolts (fig. 4a.1).
- the suction areas (fig. 4a.2) on either side are kept free.
- the mains switch for separating the instrument from the power supply is accessible any time.

**Moreover, the installation site must be free from:**

- draught by open doors or by air conditioning systems.
- direct exposure to sunlight into the cooling chamber.



**Note:**

Both measures reduce the formation of frost and therefore result in more favourable work conditions. A high air moisture as well as high ambient temperatures reduce the maximum performance of the instrument.

- To fix the complete unit, tighten the screws (fig. 4.1) by using the attached tool.
- Install the separate packed handwheel handle.



**Warning:**

Instead of the handwheel handle, a transportation screw (fig. 4b.1) is inserted into the handwheel. This way, the handwheel is tightly and securely connected with the housing of the cryostat. **It is absolutely necessary to remove this transportation screw before the initial turn-on!**

- Loosen the transportation screw (fig. 4b.1) via the Allan key, size 6.
- Now fix the separately packed handwheel handle on the handwheel with the attached screw by means of the Allan key.

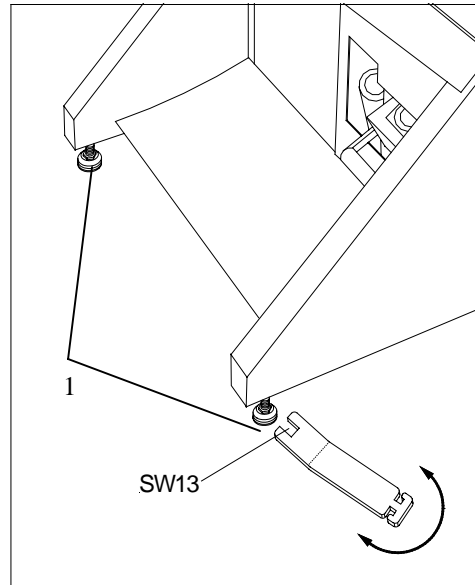

Fig. 4

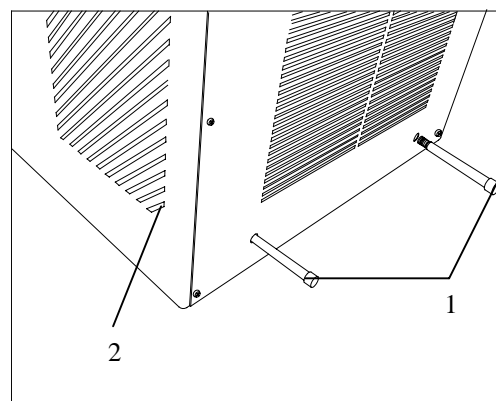

Fig. 4a

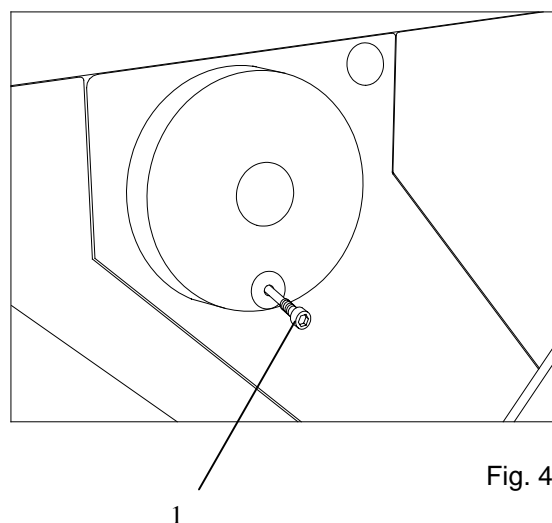

Fig. 4b

### 2-2 INITIAL TURN-ON



**Note:**

The kind of the used examination materials and all special conditions for their processing, pre-treatment and, if necessary, storage as well as instrument controls for correct and safe operation is in the responsibility of the operator. The operator is also responsible for special equipment and materials and/or reagents for the operation of the instrument.



**Warning:**

Before turning on the instrument for the first time, please check if the power requirements indicated on the type plate (fig. 6) correspond to the power supply voltage being used.

- No other instruments should be connected to the circuit used for the cryostat, as the compressor needs high surge currents when started.
- Do not use multi-socket power outlets with small wire sizes for the supply of the instrument.
- We recommend to immediately install all accessories belonging into the cryo chamber, e.g. blade carrier.
- The instruction manual of the instrument can be found in the separate carton which is placed on the foot part of the cryostat.
- Connect the power line of the instrument to the power outlet.
- Turn on the power switch (fig. 5.1) on the rear side of the instrument.
- Close the heated sliding window and cool down the instrument.

The cooling phase will take several hours depending on the set chamber temperature.

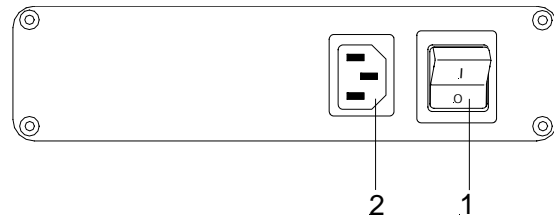

Fig. 5

- 1 = Power switch
- 2 = Mains plug

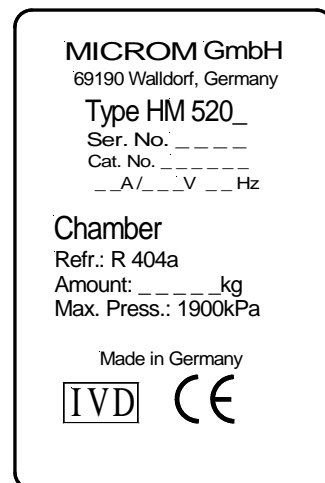

Fig. 6

### 2-3 BASIC OPERATIONAL RULES

After having turned on the instrument, the two displays show the set chamber temperature as well as the number of sections, the section thickness sum as well as the remaining travel to the front end position. Section thicknesses are indicated via LEDs.

#### 2-3-1 ACTUAL AND SET VALUE OF THE TEMPERATURE

The cooling of the microtome chamber can be controlled by the corresponding part of the operating controls. The actual temperature of the microtome chamber is shown in °C on the digital display (fig. 7.1). Briefly press the UP- or DOWN-button (fig. 7.2 or 7.3), the set value of the temperature in the microtome chamber is shown for approx. 2 sec. Afterwards, the display shows again the actual value of the temperature of the microtome chamber. To change the set value, press permanently the UP-button (fig. 7.2) or DOWN-button (fig. 7.3). The UP-button leads to higher, the DOWN-button to lower temperatures.

The valid range of the set value goes from +5°C down to -30°C. If the UP-button is used beyond the limit of +5°C, the display shows " - - -" and the temperature control is turned off. Using the DOWN-button the cooling system is turned on again.

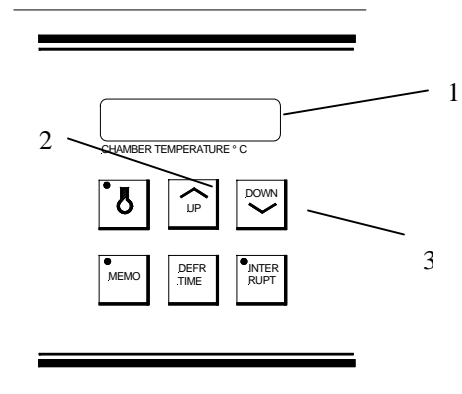

Fig. 7

## 2-3-2 DEFROSTING THE EVAPORATOR

Every 24 hours the evaporator in the rear part of the microtome chamber is defrosted automatically.

During a defrosting process, the display shows a temperature with the letter H. This temperature refers to the heating of the evaporator and not to the temperature of the cooling chamber, which is normally shown. This value, however, is of no importance for the operation of the instrument.

Press the button DEFR TIME (fig. 8.4) and the set defrosting time is shown for approx. 2 sec. on the display (fig. 8.1). It is advisable to set the time of the defrosting process not during routine working time. To change the starting time of defrosting at intervals of 15 minutes, simultaneously press the button DEFR TIME (fig. 8.4) and the button UP (fig. 8.2) or DOWN (fig. 8.3). Defrosting can only be carried out at the set defrosting time, if the real time is set correctly.

After finishing the adjusting process, the display shows the set temperature of the microtome chamber after two more seconds.

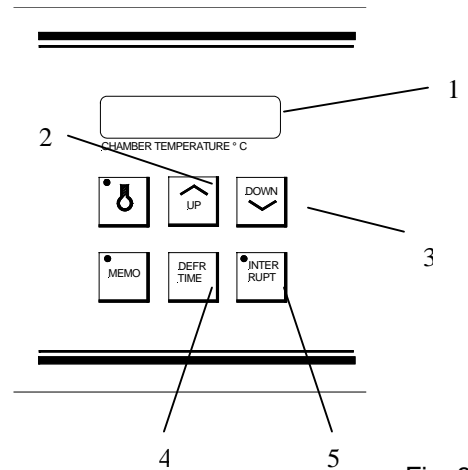

Fig. 8

**Note:**



An immediate defrosting cycle can be released at any time. For this, press the button DEFR TIME (fig. 8.4) and additionally the reset button (fig. 2.11).

## 2-3-2 INTERRUPTING A DEFROSTING CYCLE

If needed, the daily defrosting can be interrupted or cancelled. Press the button INTERRUPT (fig. 8.5), the LED in this button lights up. If the function INTERRUPT is chosen during the defrosting period, the LED blinks for the rest of the suppressed defrosting process. A cancelled or interrupted defrosting process must be repeated later on, as otherwise the evaporator will cover completely with frost and cannot cool any more.

For this, press the button (fig. 8.5) again to turn off the function INTERRUPT (LED is off). The next defrosting process will then be started when the next pre-selected defrosting time is reached.

### 2-3-3 EMPTYING THE DEFROSTING LIQUID



**Note:**

The liquid from the daily defrosting process is collected in the container (fig. 9.1). Please note that this container is emptied in due time according to the safety precautions in this instruction manual.

We highly recommend to disinfect the container with a surface disinfection solution after having emptied it.

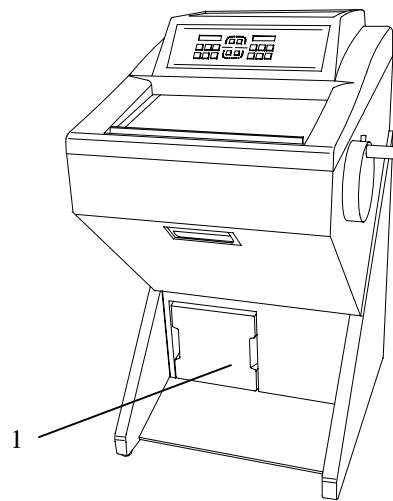

Fig. 9

### 2-3-5 ILLUMINATION OF THE COOLING CHAMBER

To illuminate the microtome chamber, a fluorescent lamp is above the chamber, which can be turned on and off by means of the button (fig. 10.1).

At low temperatures and after long periods of being turned off, the lamp might flare when turning it on.

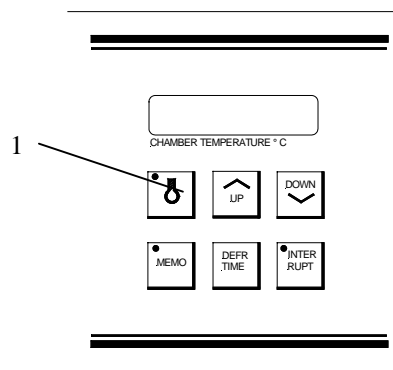

Fig. 10

### 2-3-6 FREEZING-ON OF SPECIMENS

There are several possibilities to freeze-on specimens.

Various specimen chucks are available. Round specimen chucks can be supplied with a diameter of 30 mm and 40 mm and rectangular specimen chucks with a size of 50, 55, 60 and 70 mm. Special sizes on request.

- Put the warm chuck into the hole (fig. 11.1) of the fast freezing rail.
- Put freezing medium onto the chuck.
- Place fresh tissue onto the still liquid freezing medium.
- When the medium and tissue are frozen, the chuck can be inserted into the specimen clamping and can be fixed.
- The specimen can now be sectioned.



**Note:**

The upper side of the freezing station must not be covered by frost or ice. To avoid this, use ethanol or the like.

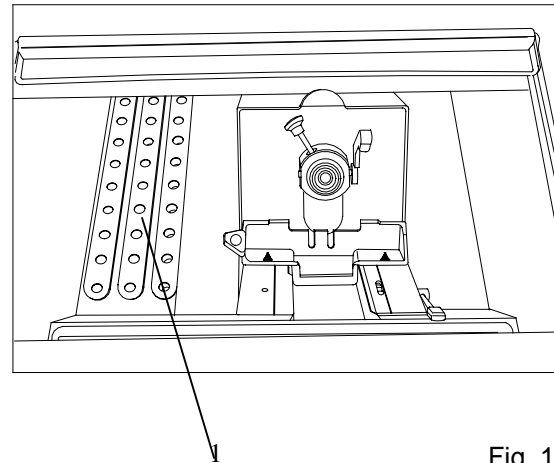

Fig. 11



Fig. 12



Fig. 13

## 2-3-7 HEAT EXTRACTORS (optional accessories)

When using a heat extractor in combination with the so-called cryo molds, the specimen is frozen faster and more evenly, as the specimen is frozen from above and below at the same time. Thus the freezing time can be reduced.

Moreover, the formation of artefacts can also be reduced considerably.

Two different heat extractors (fig. 14a and fig. 14b) are available:

### Heat extractor (fig. 14a):

- Insert the chuck (fig. 14a.3) into the fast freezing rail (fig. 14a.1).
- Then insert a cryo mold (fig. 14a.2) onto the chuck (30 or 40 mm).
- Fill freezing medium into the mold (fig. 14a.2) and place the specimen onto the freezing medium.
- The heat extractor (fig. 14a.4) is placed horizontally onto the specimen.

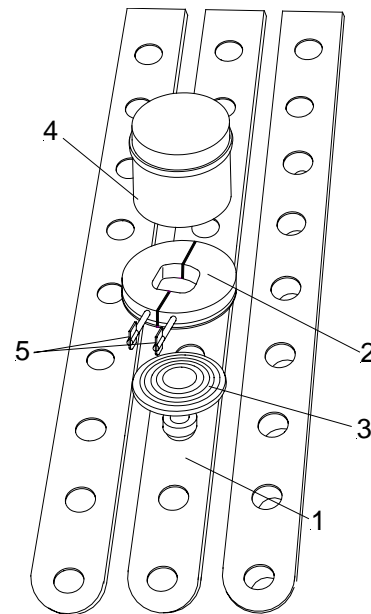

Fig. 14a



### Note:

Use both a frozen cryo mold and a frozen heat extractor.

### Heat extractor (fig. 14b):

- Insert the heat extractor (fig. 14b) into the fast freezing rail (fig. 14b.1).
- To precool the heat extractor, turn the knob (fig. 14b.2) to lower the heat extractor onto the fast freezing plate (fig. 14b.4).
- Turn the knob (fig. 14b.2) to lower the heat extractor onto the specimen (fig. 14b.3).
- Further turn the knob (fig. 14b.2) to increase the pressure onto the specimen. Carefully observe this process to avoid a possible deformation of the specimen.
- To loosen the heat extractor, turn the knob (fig. 14b.2) in opposite direction.

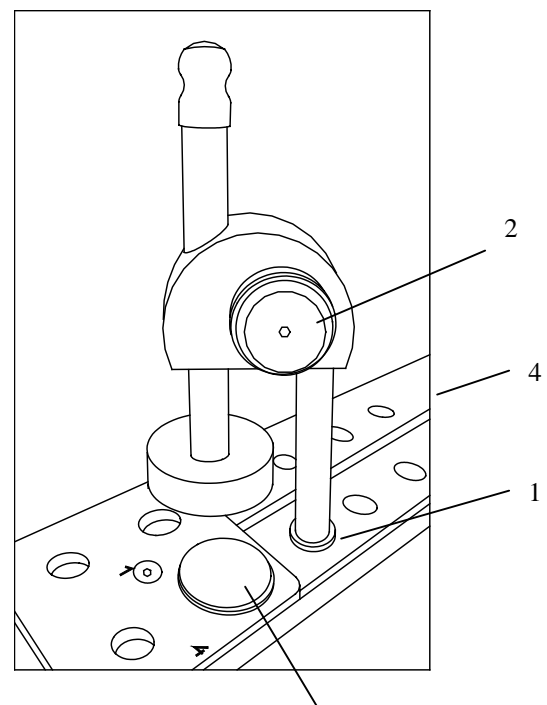

Fig. 14b

### 2-3-8 SPECIMEN ORIENTATION

In many cases, the orientation of the specimen in relation to the cutting edge would be advantageous.

This can easily be done by means of the orienting specimen holder on the microtome.

- Loosen the clamping lever (fig. 15.1).
- Via the orienting lever (fig. 15.2) the specimen clamping can be moved in all directions by approx. 8°.
- After having achieved the desired alignment, fix the position via the clamping lever.
- The orienting lever is also used for clamping the chuck into the orienting specimen holder.

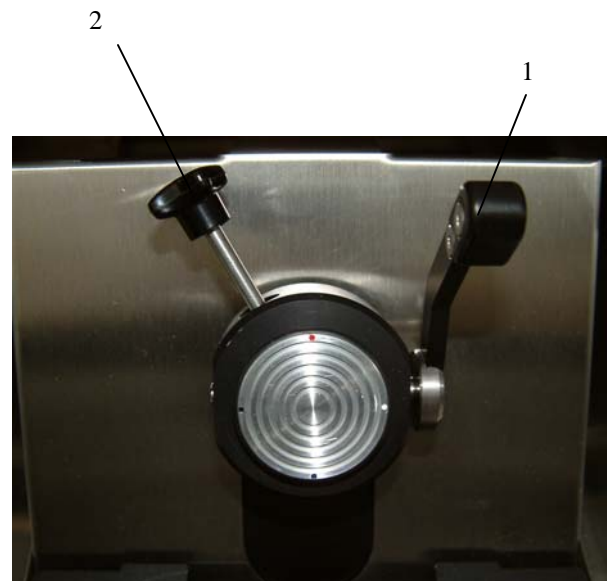

Fig. 15



**Note:**

The specimen orientation includes a zero device for the specimen (chuck is always parallel in relation to the knife).

Zero position can be felt noticeably.

**2-3-9 HANDWHEEL BRAKE**

The function <handwheel brake> allows to lock the handwheel. A pin is situated on the rim of the handwheel, which can be pressed backwards. The handwheel is locked in the upper reversal point. The danger of being injured while adjusting specimen and knife is considerably reduced.

Continue working again, first press the pin to unlock the handwheel.

**Caution!**

Lock in the handwheel brake, when working on the specimen holder and the knife carrier..

## 2-4 CUTTING PROCESS

### 2-4-1 CUTTING MOVEMENT AND RETRACTION

To start the cutting movement of the microtome, turn the handwheel. As the specimen moves down, sectioning is carried out (fig. 16.2). Continue turning the handwheel to bring the specimen back up (fig. 16.4).

To protect the knife and specimen during return travel, the specimen is retracted (R). Then the LED RETRACT on the operating panel lights up.

X=selected section thickness  
 1=specimen  
 2=cutting movement  
 3=knife  
 4=return travel  
 R=retraction

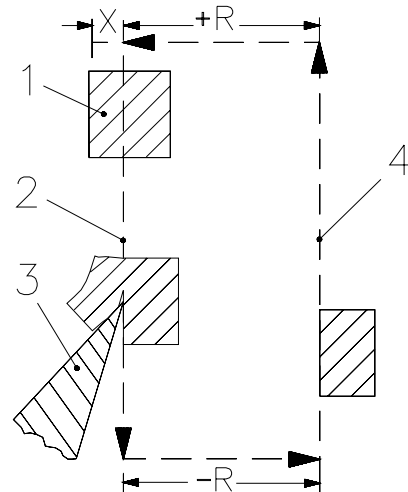

Fig. 16

### 2-4-2 SETTING SECTION THICKNESS AND TRIMMING THICKNESS

The desired section thickness can be selected by means of the buttons (fig. 17.1) on the operating controls and the trimming thickness by means of the buttons (fig. 17.2). The two left buttons lead to lower values and the two right buttons to higher values.

The selected values are also indicated by the corresponding illuminated LEDs.

The two orange LEDs (fig. 17.3) show which section thickness mode is chosen.

The graduation of the section thicknesses (which can be pre-selected) is divided into 2 ranges:

range	graduation
from 2 $\mu\text{m}$ to 10 $\mu\text{m}$	1 $\mu\text{m}$
from 10 $\mu\text{m}$ to 22 $\mu\text{m}$	2 $\mu\text{m}$

The graduation of the trimming thicknesses (which can be pre-selected) is divided into 4 ranges:

range	graduation
from 10 $\mu\text{m}$ to 80 $\mu\text{m}$	10 $\mu\text{m}$
from 80 $\mu\text{m}$ to 100 $\mu\text{m}$	20 $\mu\text{m}$
from 100 $\mu\text{m}$ to 300 $\mu\text{m}$	50 $\mu\text{m}$
from 300 $\mu\text{m}$ to 500 $\mu\text{m}$	100 $\mu\text{m}$

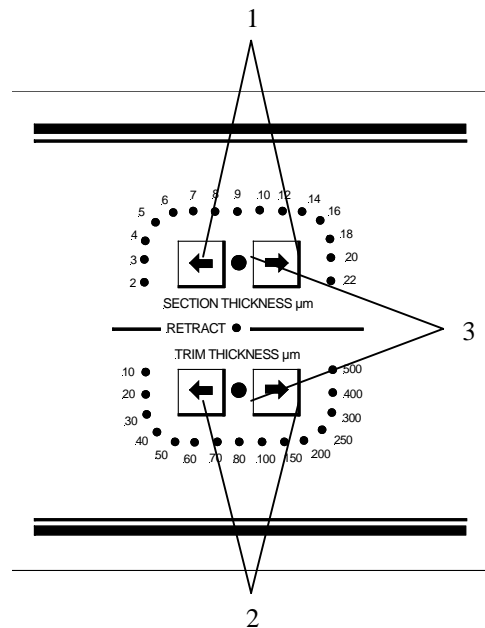

Fig. 17

## 2-5 FEED

### 2-5-1 SPECIMEN COARSE FEED

For the fast forward and backward travel between knife and specimen, the cryostat microtome has a motorized coarse feed system.

To move the specimen holder backwards, press the button <coarse feed backwards> (fig. 18.1).

For short distances, press the button (fig. 18.1) only slightly. If this button is pressed for more than approx. 2 sec. the specimen holder moves automatically to the back end position and the motorized coarse feed shuts off. This function can be stopped at any time. For this, slightly press the button again.

When the back end position is reached, the LED lights up.



**Caution!**

For your personal safety, before activating the coarse feed forwards, move the anti-roll plate onto the blade against possible splintering of the blade. This might be caused by an incorrect coarse feed function.



**Caution!**

With the function <coarse feed forwards> specimen and knife edge are adjusted very quickly. To avoid damage to specimen and knife, carefully observe this adjustment process.

The specimen holder is moved to the front as long as the button <coarse feed forwards> (fig. 18.2) is being pressed.

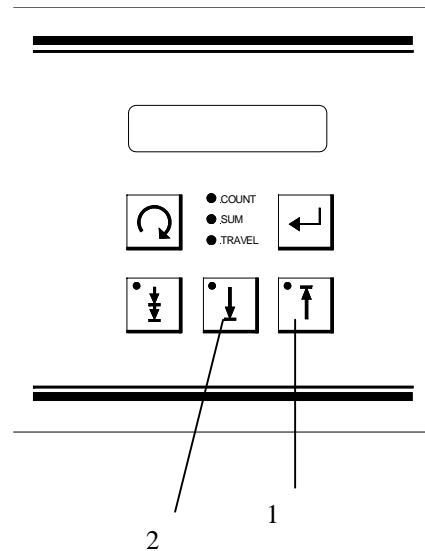

Fig. 18

Take note that the specimen and knife edge do not come in contact with each other. Carefully observe the narrowing gap between knife edge and specimen to stop the function <coarse feed forwards> in time before the specimen touches the knife edge.

When the front end position is reached, the motorized coarse feed is turned off. Then the LED in button lights up.



**Note!**

At the beginning of a sectioning series, it is advisable to use the coarse feed to move the specimen to the back third of the horizontal specimen movement, and, if necessary, to move the knife carrier towards the specimen.

### 2-5-2 MEMORY FUNCTION

The memory function allows the automatic approach between specimen and knife.

It is used to find again the first cut position in a very fast way.

This function can only be used on condition that blocks, which have been embedded in the same molds, are cut. The blocks must have almost the same height.

To set the first cut position, please proceed as follows:

- Press the memo button (fig. 19.1) in the desired position until the LED briefly lights up in this button.
- The position is now stored.
- The following message is shown on the display (fig. 19.2): POS.
- Press the memo button (fig. 19.1) again to move to this stored position later on.

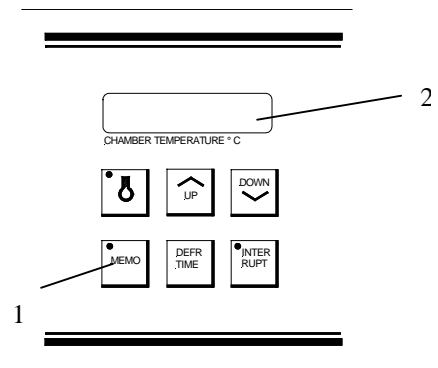

Fig. 19

### 2-5-3 TRIMMING AND FIRST CUTS

After the specimen and the knife are adjusted, further gradual feed for trimming can be carried out using the function <trimming>. For different sectioning series, deeper layers of the specimen can be reached with the function <trimming>.

The pre-selected trimming value is indicated by a corresponding LED which then lights up. To select another trimming value, press buttons (fig. 2.2 and 2.3).

Button (fig. 20.1) is used for trimming, available as pulse or permanent function.

The <pulse function> is used when there is still some distance between specimen and knife edge.

Press the button (not longer than 2 sec.). Whenever the button is pressed, the specimen holder together with the specimen moves forwards by the trimming value which was pre-selected.

To select the <permanent function> press the button for more than approx. 2 sec. Then the yellow LED in this button lights up continuously and permanent trimming is selected. In addition, the yellow LED lights up to show that the selected trimming value is activated. The feed is carried out at each handwheel rotation in the upper reversal point. Press the button once more, to turn off the permanent trimming. The yellow LED in this button goes off.

The yellow LED (fig. 20.1) also goes off. However, the yellow LED lights up to indicate that the function fine sectioning is activated.

The <permanent function> is used to get faster to the desired sectioning level.

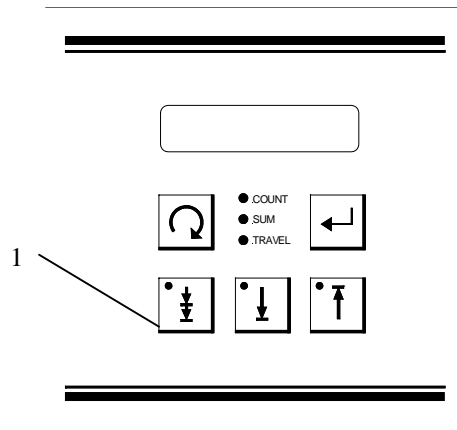

Fig. 20

### 2-5-4 FINE FEED

After having adjusted knife and specimen as well as having trimmed the specimen, sectioning can be started.

Turn the handwheel continuously in one direction to feed the specimen at the selected section thickness.

The pre-selected section thickness is indicated by the corresponding LED which then lights up.

To select another section value, press button (fig. 2.2).

## 2-6 INDICATION OF CUTTING PROCESSES

Information on the sectioning status can be seen on the display (fig. 21.1). Press the scroll button (fig. 21.2) to show the various functions one after the other.

The following information on the present sectioning position of the instrument can alternatively be seen on the display:

- number of sections  
(the yellow LED COUNT lights up)
- sum of section thicknesses  
(the yellow LED SUM lights up)
- remaining travel to front end position  
(the yellow LED TRAVEL lights up)

For this, press the scroll button (fig. 21.2) until the corresponding yellow LED lights up and the desired information is shown on the display.

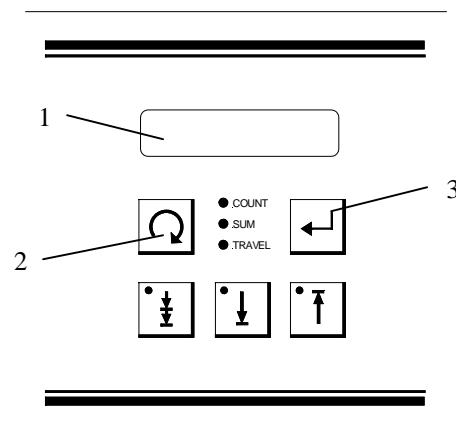

Fig. 21

### 2-6-1 SECTION COUNTER

The section counter adds up the sections produced. After each downward movement of the specimen holder, the number on the section counter increases by 1. The counter can be reset to zero by means of the RESET-button (fig. 21.3).

### 2-6-2 SUM OF SECTION THICKNESSES

This value shows the sum in microns of the sections already cut. Trimming values as well as sectioning values are added up. This value can also be reset to zero by means of the RESET-button (fig. 21.3).

### 2-6-3 REMAINING TRAVEL TO FRONT END POSITION

This value shows the distance, which is left for sectioning.

If the specimen holder is in the rear end position, the display shows 28 000  $\mu\text{m}$ . This number decreases, the closer the specimen comes towards the front. If no further feed is possible anymore, the display shows automatically the remaining travel to the front end position. Independently, which information about the sectioning position was chosen before.

### 2-6-4 SETTING THE REAL TIME

The real time can be read on the display if the memo button (fig. 22.1) is pressed in addition to the already pressed button DEFR TIME (fig. 22.2).

To correct the real time at intervals of one minute, additionally press the UP- or DOWN-buttons (fig. 22.3 or 22.4).

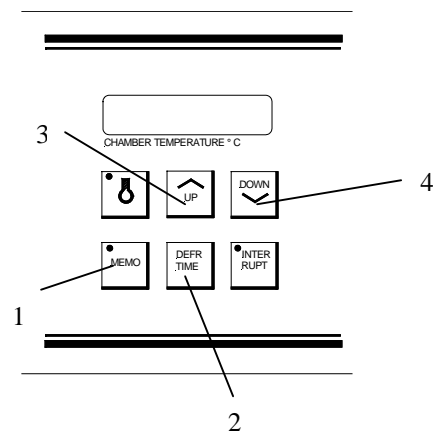
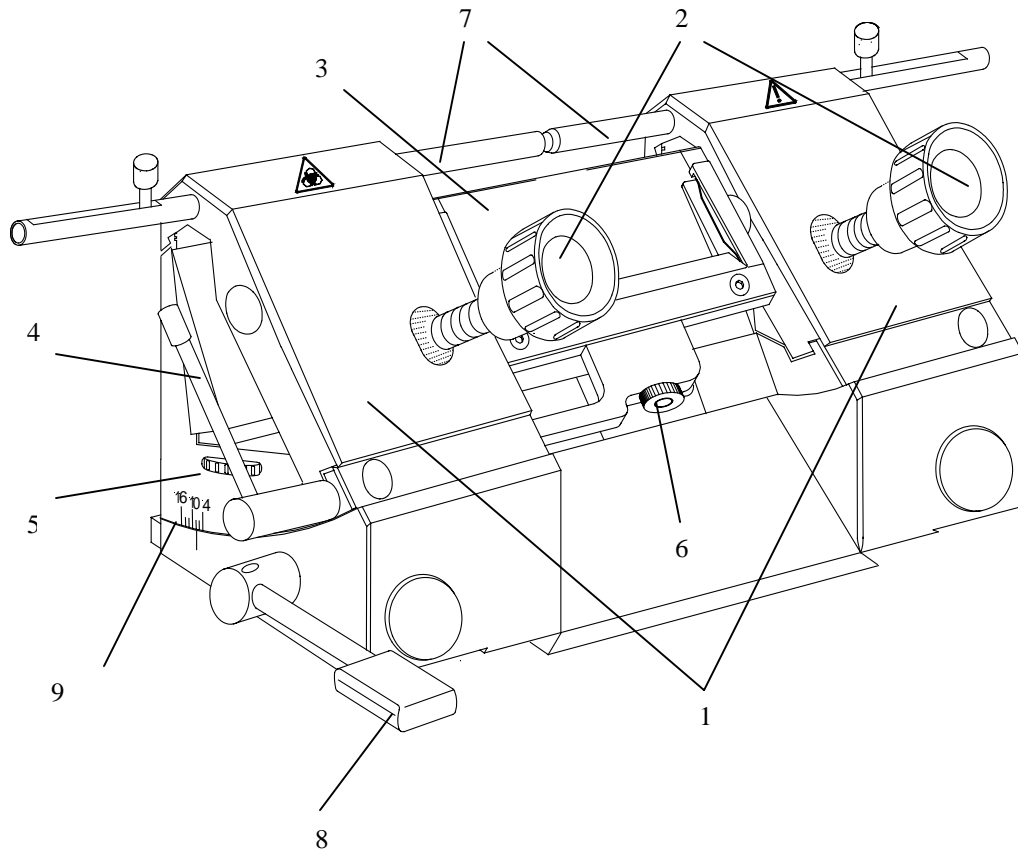

Fig. 22

**2-7 KNIFE CARRIERS**

**2-7-1 STANDARD KNIFE CARRIER**

The standard knife carrier of the cryostat is easy to use. The knife can be inserted either from the side or from the front. The standard knife holder takes up commercially available conventional knives with c- and d-profiles.



**Fig. 23**

### Inserting the knife:

- The knife is inserted into the knife carrier either from the side or from the front, independently if one or two clamping plates (fig. 23.1) have been removed.
- Loosen the clamping screws (fig. 23.2).
- Turn the turning lever (fig. 23.4) in a clockwise direction to tilt the anti-roll plate (fig. 23.3) forwards.
- Insert the knife.
- Turn the turning lever (fig. 23.4) in a counter clockwise direction to put the anti-roll plate (fig. 23.3) against the knife.



#### Note:

Insert the glass anti-roll plate parallel towards the blade edge.

- Then tighten the clamping screws (fig. 23.2) to fix the knife in its position.

### If the cutting area of the knife is no longer usable, the knife can be moved:

- Open the clamping screws (fig. 23.2) and move the knife to the left or right side as required.
- Fix the knife again via the clamping screws (fig. 23.2).



#### Caution:

To avoid the danger of injury on the knife during adjustment of specimen, always position the knife guards (fig. 23.7) over the blade edge.

### Height adjustment of the knife:

- Loosen the clamping screws (fig. 23.2).
- Via the knurled screws (fig. 23.5) which are placed on the left and right side of the knife carrier adjust the height of the knife to the position of the anti-roll device.



#### Note:

Please note the parallel alignment of knife edge and edge of the anti-roll plate.

- Afterwards, tighten the clamping screws (fig. 23.2) to fix the knife in its position.

### **Fine adjustment of the anti-roll device:**

- The fine adjustment of the anti-roll device is carried out via the knurled screw (fig. 23.6).

### **Selecting the clearance angle:**

- Loosen the clamping lever (fig. 23.8) on the left side of the knife carrier.
- Swivel the upper part of the knife carrier on the base until the desired clearance angle is reached.
- The clearance angle can be read on the scale (fig. 23.9) on the left side on the base.
- Bring the clamping lever (fig. 23.8) upwards into clamping position.
- The selected clearance angle is now fixed in its position.



### **Note:**

Usable cuts are only achieved at a clearance angle of 10° or more!

### 2-7-2 DISPOSABLE BLADE CARRIER

The disposable blade carrier takes up all commercially available low profile blades with a dimension of 80 x 8 mm and a facette angle of approx. 35° and as another version it takes also up high profile blades. The anti-roll plates have a length of 39,5 mm.

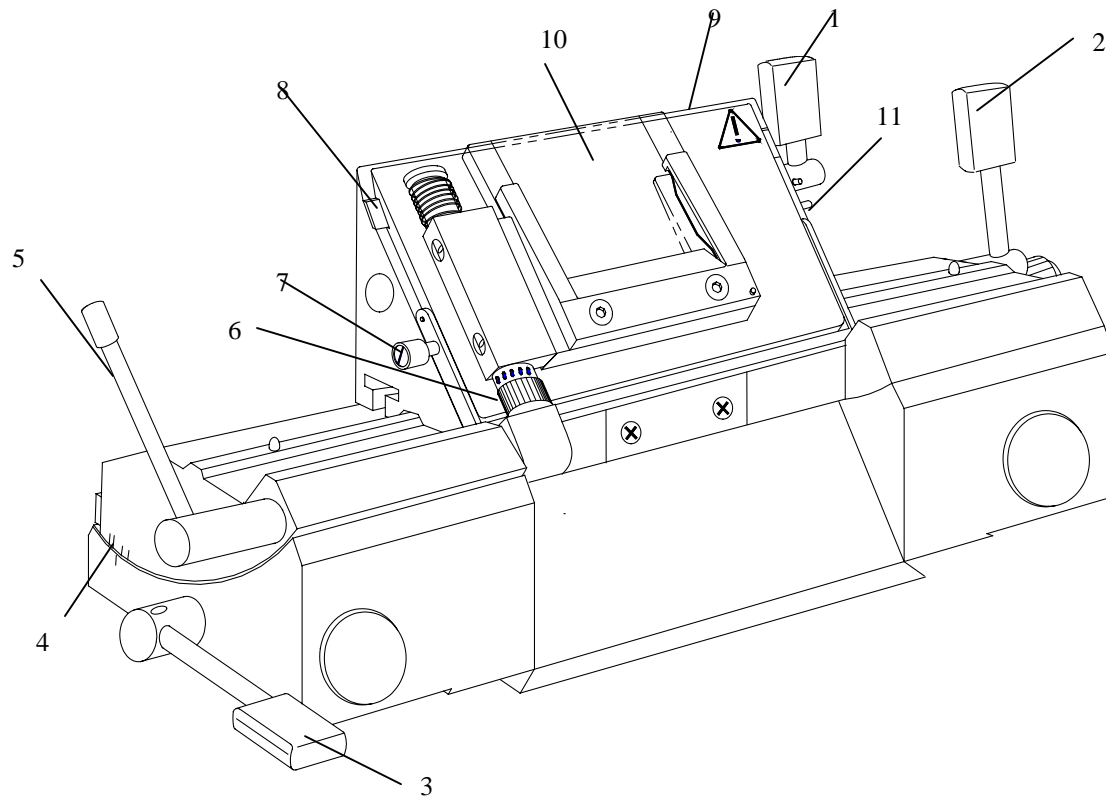

Fig. 24

## Inserting the blade:

- The blade is inserted into the slot (fig. 24.9) behind the clamping plate.



### Note:

When using high profile blades, first loosen the lever (fig. 24.1) and remove the spacer strip (fig. 24.8).

- For this, push in the stop bolt (fig. 24.11) and turn the clamping lever (fig. 24.1) in a counter clockwise direction over the stop bolt.
- Remove the clamping lever (fig. 24.1) together with the eccentric bolt.
- First remove the clamping plate and then the spacer strip.
- Fix the clamping plate with clamping lever (fig. 24.1) again in the blade carrier in reverse order.
- To insert the blade, now loosen the clamping lever (fig. 24.1).



### Note:

Press the clamping plate on its lower area to open the slot behind the clamping plate.

- Insert the blade from the left side into the slot behind the clamping plate (fig. 24.9) as far as possible.
- To section the specimen, put the anti-roll plate (fig. 24.10) against the blade via the turning lever (fig. 24.5) in a counter-clockwise direction.
- Tighten the clamping lever (fig. 24.1). Thus fixing the blade in its position.

## If the cutting area of the blade is no longer usable, the blade carrier can be moved:

- The blade itself is clamped solidly into the blade carrier. The complete carrier is moved.
- Open the clamping lever for the upper part of the carrier (fig. 24.2) and move the blade together with the upper part to the left or right side.
- Tighten the clamping levers (fig. 24.2) to fix this position.



**Caution:**

To avoid the danger of injury on the blade during adjustment of specimen, always position the knife guards (fig. 24.7) over the blade edge.

**Fine adjustment of the anti-roll device:**

- The fine adjustment of the anti-roll plate is carried out via the knurled screw (fig. 24.6).



**Note:**

Insert the glass anti-roll plate parallel towards the blade edge.

**Selecting the clearance angle:**

- Loosen the clamping lever (fig. 24.3).
- Swivel the upper part of the blade carrier on the base until the desired clearance angle is reached.
- The clearance angle can be read on the scale (fig. 24.4) on the left side on the base.
- Bring the clamping lever (fig. 24.3) into clamping position.
- The selected clearance angle is now fixed in its position.



**Note:**

Usable cuts are only achieved at a clearance angle of 10° or more!

**2-7-3 DISPOSABLE BLADE CARRIER EC 70**

The disposable blade carrier EC takes up all commercially available low profile blades with a dimension of 80 x 8 mm and a facette angle of approx. 35° and as another version it takes also up high profile blades. The anti-roll plates have a length of 69,5 mm.

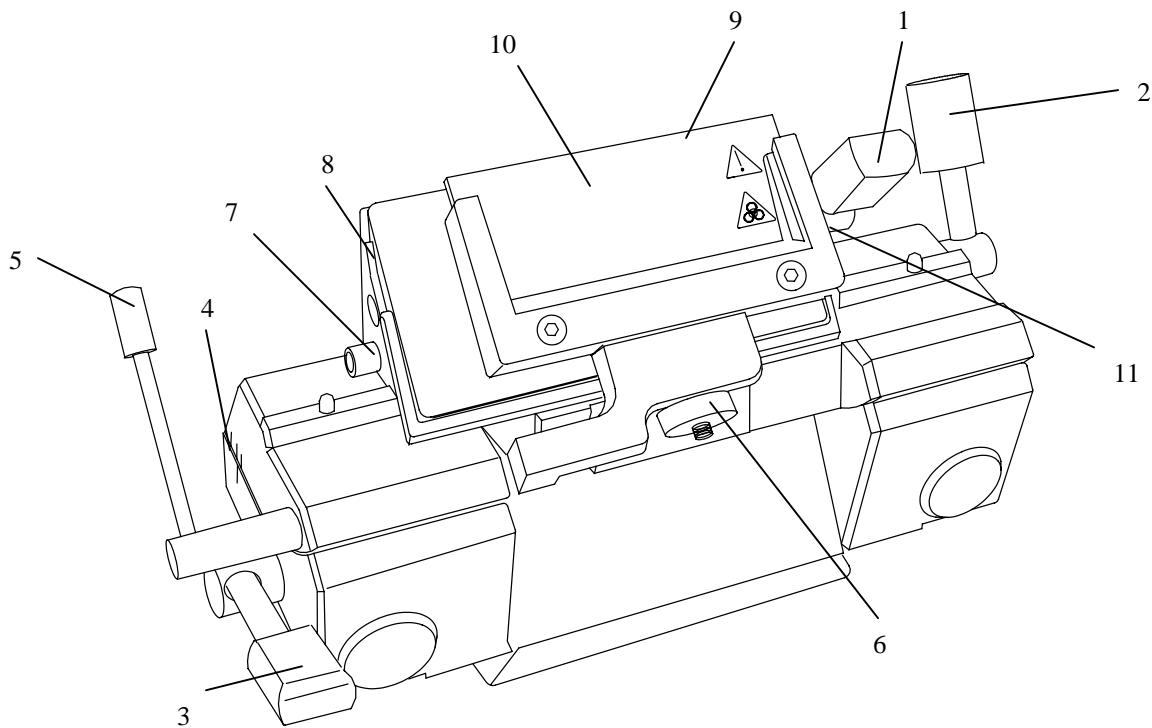

Fig. 24a

## Inserting the blade:

- The blade is inserted into the slot (fig. 24a.9) behind the clamping plate.



### Note:

When using high profile blades, first loosen the lever (fig. 24a.1) and remove the spacer strip (fig. 24a.8).

- For this, push in the stop bolt (fig. 24a.11) and turn the clamping lever (fig. 24a.1) in a counter clockwise direction over the stop bolt.
- Remove the clamping lever (fig. 24a.1) together with the eccentric bolt.
- First remove the clamping plate and then the spacer strip.
- Fix the clamping plate with clamping lever (fig. 24a.1) again in the blade carrier in reverse order.
- To insert the blade, now loosen the clamping lever (fig. 24a.1).



### Note:

Press the clamping plate on its lower area to open the slot behind the clamping plate.

- Insert the blade from the left side into the slot behind the clamping plate (fig. 24a.9) as far as possible.
- To section the specimen, put the anti-roll plate (fig. 24a.10) against the blade via the turning lever (fig. 24a.5) in a counter-clockwise direction.
- Tighten the clamping lever (fig. 24a.1). Thus fixing the blade in its position.

## If the cutting area of the blade is no longer usable, the blade carrier can be moved:

- The blade itself is clamped solidly into the blade carrier. The complete carrier is moved.
- Open the clamping lever for the upper part of the carrier (fig. 24a.2) and move the blade together with the upper part to the left or right side.
- Tighten the clamping levers (fig. 24a.2) to fix this position.



**Caution:**

To avoid the danger of injury on the blade during adjustment of specimen, always position the knife guards (fig. 24a.7) over the blade edge.

**Fine adjustment of the anti-roll device:**

- The fine adjustment of the anti-roll plate is carried out via the knurled screw (fig. 24a.6).



**Note:**

Insert the glass anti-roll plate parallel towards the blade edge.

**Selecting the clearance angle:**

- Loosen the clamping lever (fig. 24a.3).
- Swivel the upper part of the blade carrier on the base until the desired clearance angle is reached.
- The clearance angle can be read on the scale (fig. 24a.4) on the left side on the base.
- Bring the clamping lever (fig. 24a.3) into clamping position.
- The selected clearance angle is now fixed in its position.



**Note:**

Usable cuts are only achieved at a clearance angle of 10° or more!

## **2-8 ERROR CODE INDICATION**

The instrument has an error code indication to define faster and better possible malfunctions.

The error codes E-01, E-02 and E-04 refer to the function of the integrated feed mechanism and to the condition of the battery buffer for storing data and is shown on the left display.

The error code E-03 refers to the temperature of the cooling chamber and is shown on the right display.

### **2-8-1 DEFINITION OF THE ERROR CODES**

The error code E-01 is shown on the left display and indicates that there is a malfunction in the power amplifier of the instrument.

The user now knows that the integrated feed mechanism is not ready to operate.

In this case, a trained service technician must be called.

The error code E-02 is also shown on the left display and indicates that the battery for the stored data is empty. This means that the indication of the real time clock as well as of the defrost timer is wrong. However, the instrument can be operated.

After a few seconds the error code E-02 disappears automatically. The variable values are then cleared. The set value of the temperature is adjusted to a default value. To select other values, press the UP or DOWN buttons.

The battery should then be replaced by a trained service technician as soon as possible.

The error code E-03 is shown on the right display, if the temperature of the cooling chamber is higher than 0° when turning on the instrument. This error code indicates that no cooling process was carried out for a longer time caused by power failure or turning off the instrument. In these cases, the instrument warms up and the cooling chamber as well as the microtome with knife carrier of the instrument gets wet or humid.

To avoid that the wet microtome is cooled down and consequently the guides freeze solid, the error code E-03 is shown on the display. Now the microtome together with the knife carrier must be dried.

The user is to make sure that the microtome is in a perfectly dry condition. Then press the memo button (fig. 2.12) to start the cooling process. The error code E-03 goes off and the cooling process starts.

The error code E-04 is shown on the left display if the rear end position of the integrated feed system is not reached within 2 min. after turning on the instrument. The instrument can be operated, however, the rear end position is not defined. For this, press the memo button. The error code E-04 goes off.

**2-9 ACCESSORIES****2-9-1 STANDARD EQUIPMENT**

The microtome cryostat HM 520 is equipped with the following accessories:

	Cat. No.
6 specimen chucks, 30 mm round	715220
1 Allen key 2,5 mm	362220
1 Allen key 5 mm	362260
1 Allen key 6 mm	362120
1 flat brush	334170
1 brush	334160
1 cryostat oil no. 407      100 ml	350040
1 freezing medium 118 ml	161425
1 brush shelf	415640
2 distance bolts	570110
1 instruction manual	387772

**2-9-2 ADDITIONAL EQUIPMENT (OPTIONAL)**

Cat. No.

Specimen chucks:

∅ 20 mm	715700
∅ 30 mm	715220
∅ 40 mm	715230
50 x 50 mm	715730
55 x 55 mm	715740
60 x 55 mm	715750
70 x 55 mm	715760

Cryo-Molds:

10 mm	570400
15 mm	570380
22 mm	570390

Knife carriers:

Standard knife carrier	705460
Disposable blade carrier EC 70	705630

Other accessories:

Heat extractor	524510
Disposable blade SEC 35 (50 pcs. in dispenser)	152200

---

## **3 THEORY OF OPERATION**

---

### **3-1 CHAMBER COOLING, DEFROSTING**

The chamber of the cryostat is cooled by a refrigeration machine. In the rear upper area of the microtome chamber is the evaporator which the cold coolant flows through. Due to the heat extraction from the microtome chamber a cooling down to  $-30^{\circ}\text{C}$  can be achieved.

On the left side of the cooling chamber there are 27 freezing stations to quickly freeze-on specimens onto specimen stages.

Use the heat extractor to accelerate the freezing of the specimen.

The temperature of the microtome chamber can be adjusted continuously down to  $-30^{\circ}\text{C}$ . For this, pre-select the desired temperature as set value on the operating controls.

The actual value of the microtome is constantly measured and sent to the control unit which causes the refrigeration to switch on and off.

Inevitably, when working on the microtome the dry cold air of the microtome chamber mixes with the warm humid air outside the chamber. Frost forms on the finned evaporator. The increasing thickness of the frost reduces the efficiency of the evaporator. For this reason, the daily defrosting of the evaporator becomes necessary.

Set the time of the daily defrosting on the operating controls. The period of the defrosting takes approx. 30 min. and varies according to the thickness of the frost.

Possible frost built-up on the microtome or on the knife carrier are not removed by defrosting the instrument. However, the frost recedes after defrosting as now the evaporator is fully efficient again.

To avoid condensation the sliding window is heated.

### **3-2 CUTTING MOVEMENT**

The microtome of this cryostat is a rustproof rotary microtome. The cutting movement is carried out turning the handwheel.

The rotary movement results in the vertical movement of the specimen orientation which carries the specimen holder with the specimen. The specimen is moved up- and downwards close to the knife edge. The knife is clamped securely into the knife carrier.

The section thickness is delivered at the upper reversal point of the vertical movement. The specimen holder together with the specimen moves to the front by the size of the section thickness, which can be selected on the operating controls.

With the downward movement of the specimen, sectioning is carried out. During the return travel, the specimen is drawn back automatically to protect knife and specimen, which means that the knife can be used longer and that the specimen is protected against artefacts.

The number of sections made is indicated on the section counter. After each downward movement of the specimen holder, the number on the section counter increases by 1. The section counter can be re-set to zero at any time.

The sum of sections made can also be seen on the display. For this, trimming value and sectioning values are added up. Section counter and sum of section thicknesses can be reset to zero at any time by means of the reset button.

Moreover, the remaining travel to the front end position can also be shown on the display. The remaining travel, which is still available for sectioning, is shown in microns.

**3-3 SPECIMEN COARSE FEED  
AND TRIMMING STAGES**

After changing the specimen, moving the knife or knife carrier, it is necessary to adjust the specimen to the knife edge again. This can easily be done by means of the specimen coarse feed and the defined trimming values.

To move the specimen holder electronically forwards or backwards, use the corresponding buttons on the operating controls.

After the specimen and knife are adjusted, further gradual feed for trimming can be carried out by using the function <trimming>. Whenever pressing the button <trimming>, the motorized feed is released. The same happens, when the function <trimming> is stored and the handwheel is turned.

---

## **4 WORKING WITH THE CRYOSTAT**

---

### **4-1 PREPARING THE COOLING CHAMBER**

Before sectioning, the microtome chamber should be at a stable temperature around the desired cutting temperature. The temperature of the knife is determined by the cooling of the microtome chamber.

All tools which are necessary to take off sections or to manipulate the specimen must also be cooled, as the section will stick to them. For this reason, the required working accessories should always be stored on the shelves or brush tray in the microtome chamber.

The heated sliding window should be closed during breaks and while preparing work to avoid warm air getting into the chamber. Consequently, more favourable work conditions with a lower frost built-up on the microtome and knife are achieved.

### **4-2 FREEZING-ON THE SPECIMEN**

The specimen is frozen-on to the specimen stage with clinging grooves with a freezing compound.

To freeze-on specimens, use the fast freezing device on the left side of the chamber.

When using the fast freezing device put some freezing compound onto the specimen stage, which should be outside the chamber at a low positive temperature. Then put the specimen onto the stage and surround it with some freezing compound.

Then insert the specimen stage into one of the fast freezing stations.

If the instrument is equipped with a heat extractor (additional equipment) the specimen can be frozen faster and more evenly. Put the heat extractor onto the specimen from above. This way, the specimen is frozen at the same time from above and below, which reduces the formation of artefacts considerably.

**4-3 ORIENTATION AND TRIMMING**

Clamp the specimen stage together with the frozen specimen into the specimen holder. Tighten the orienting lever (fig. 15.2) in a clockwise direction. Loosen the clamping lever (fig. 15.1) to have the possibility to adjust the specimen parallel in relation to the cutting edge by means of the orienting lever. Then press the clamping lever backwards. With the motorized coarse feed specimen and knife edge can roughly be adjusted.

Then carry out a further gradual feed by using the function <trimming>. Turn the handwheel in a clockwise direction resulting in the first contact between knife and specimen. Continue this thus achieving the desired level. Any waste should be wiped away in an upward direction with a brush.

## 4-4 TEMPERATURE LIST FOR CRYO-SECTIONING

The optimal cutting temperature of a specimen depends on the respective characteristics of the tissue especially on the fat content. The following table won by experience recommends cutting temperatures for some typical applications:

Range A -10 to -20°C

Liver  
Kidney  
Spleen  
Thyroid  
Lymph Node  
Uterine Curettings  
Tongue  
Testicle

Range B -20 to -30°C

Muscle  
Breast without fat  
Brain  
Bone Marrow  
Lungs  
Intestine  
Prostata  
Cervix  
Uterus  
Pancreas  
Adrenal  
Skin without fat

Range C -30 to -60°C

additional cooling with  
liquid nitrogen or dry ice  
might be necessary

Adipose  
Omentum  
Breast with fat  
Skin with fat  
Cheese  
Butter  
Industrial Waxes  
Soft Rubber



**Note:**

The indicated cutting temperatures are subject to a tolerance, as the fat contents of the tissue differ or pathological tissue shows natural variations.

**4-5 SECTIONING AND TAKING  
OFF SECTIONS**

For sectioning, pre-select the desired section thickness by means of the buttons on the operating controls. Put the anti-roll plate against the knife by means of the knob. Turn the handwheel in a clockwise direction to carry out sectioning. The section slides into the space between the knife and the anti-roll guide.

Then remove the anti-roll guide by means of the knob. The section sticks to the knife surface. Transfer the specimen now onto a slide by using a brush or tweezers.

## 4-6 HOW TO AVOID MALFUNCTIONS

To cut usable sections, the following points are of utmost importance:

- Condition of the knife edge, probably move it horizontally to the left or right side.
- Check adjustment of anti-roll guide and correct it, if necessary.
- Carefully remove frost from front and rear part of the knife and from the anti-roll plate (i.e. with ethanol, acetone or the like).
- Tighten all clamping screws and clamping levers on the knife carrier and specimen holder.
- Select the appropriate cutting temperature according to the specimen (see part 4-4).
- Select the appropriate freezing medium.



### Note:

If the specimen was frozen with liquid nitrogen or similar freezing techniques, the specimen must adapt itself to the cutting temperature.

- Carefully select the required knife material and profile.
- Adjustment of knife height.
- Adjustment of proper clearance angle. Select a clearance angle of 5-15° according to the facet angle of a steel knife.
- Select a proper cutting speed: The harder the material, the slower the cutting speed!
- Take care in bringing specimen and knife together.



### WARNING:

During defrosting, remove the specimens from the cooling chamber, as the temperature inside the chamber will increase.

Do not leave or store tissue inside the cryostat over a longer period. Due to a power failure or other unexpected malfunctions of the instrument, the specimen might be damaged.

## 4-6-1 POSSIBLE SOURCES OF ERRORS – CAUSE AND REMOVAL

Problem	Cause	Removal
Cryostat temperature cannot be achieved	Ambient temperature too high	Lower ambient temperature by fresh air, climate. Please note the specified temperature of +20°C!
	Cryostat is influenced by near, heat-generating instruments	Change site of installation
	Draught into the cryostat	Change site of installation
	Soiled condenser	Open the service door on the left side, clean the condenser
	Defective cooling	Call a service technician
Frost built-up on chamber wall and on microtome	Draught (open doors, windows)	Change site of installation; close windows, doors
Retarded freezing-on of the specimen	Surface of the fast freezing station is soiled	Remove debris
	Lower part of the chuck is soiled or damaged	Remove debris, remove damage
Chatter while cutting	Unfavorable clearance angle	Readjust clearance angle
	Insufficient knife sharpness	Move the knife in the knife carrier
	Knife not adequately clamped	Check knife clamping
	Chuck inadequately clamped	Check clamping
	Specimen inadequately frozen on onto the chuck	Again freeze on the specimen
	Specimen grossed too thick – it loosens from the chuck	Again freeze on the specimen
Sticky sections	Specimen not cold enough	Select a deeper temperature
	Knife and/or anti-roll plate are not yet cold enough – section melts	Wait until the knife and/or the anti-roll plate have reached the corresponding chamber temperature

Sections do not stretch, although the correct temperature has been selected and the anti-roll plate has been adjusted correctly	Knife and/or anti-roll plate are not clean	Clean with a dry cloth or brush
	Edge of anti-roll plate is damaged	Replace anti-roll plate
Sections break, fissures in the sections, sections are not stretched properly	Blunt knife	Move the knife
	Specimen too cold	Select a higher temperature
	Static charge/draught	Remove the cause
	Specimen not cold enough	Select a deeper temperature
	Spacious specimen	Trim the specimen in a parallel way; select a thicker section thickness
	Anti-roll plate not adjusted properly	Readjust the anti-roll plate
	Anti-roll plate not aligned parallel towards the knife edge	Align parallel
	Incorrect clearance angle	Readjust the clearance angle
	Blunt knife	Move the knife
Sections roll over the anti-roll plate	Anti-roll plate does not project over the knife edge properly	Readjust the anti-roll plate
Scratching noise while cutting and during the return travel of the specimen clamping	Anti-roll plate projects over the knife edge too much and scratches on the specimen	Readjust the anti-roll plate
Thick-thin-sections	Knife sharpness	Move the knife
	Knife angle	Readjust
	Clamping on knife carrier	Check clamping
	Clamping on specimen holder	Check clamping
Tight handwheel punctual	Debris and section waste between microtome and base plate	Remove and clean
during the entire movement	Soiled link block Toothed belt tension	Please call a service technician
No chamber illumination	Defective lamp	Check, replace
	Defective starter	Check, replace



**Note:**

In case of malfunctions and/or service work, please turn off the instrument and contact your local dealer.

---

## 5 MAINTENANCE AND CARE OF THE CRYOSTAT

---

### 5-1 SHUTTING-OFF FOR CLEANING

Cleaning, care and decontamination of the cryostat depends on how frequently the instrument is used. However, it is recommended to shut the instrument off every 6 - 8 weeks.

**Caution/Biohazard:**

As the following work might be hazardous because of the danger of freezer burns on frozen parts and potential contaminated material, it should only be done by skilled or trained personnel.



Please proceed as follows:

- Wear protective gloves.
- Remove knife/blade from the knife carrier and store it in a knife case.
- Remove the brush shelf, tools as well as chucks.
- Bring the handwheel handle into its upper position, i.e. the specimen clamping is also in its upper position.
- Remove the middle and rear section waste tray. Dispose of the section waste according to the respective lab regulations.
- Remove and/or suck off cold section waste.
- Turn off the mains switch and unplug the unit.
- Loosen the clamping lever on the knife carrier and pull off the knife carrier. If necessary, treat it with disinfectant.

**Caution:**

Caution of freezer burns due to the frozen knife carrier.

- Remove the left and right side sheets.
- Remove the sheets on the black grips with a circular movement upwards/forwards.

### 5-2 REMOVING THE MICROTOME

- In the left rear part of the microtome there is the so-called connector housing including one electrical connection.
- Bring the handwheel handle into its lower position, i.e. the specimen clamping is also in its lower position.
- Unscrew the Allan screw (fig. 25.1) in the middle of the front part of the microtome base plate via an Allen screwdriver size 5 mm.



**Caution:**

It is recommended for all further work to wear isolating gloves because of the danger of freezer burns on the frozen microtome.

- Move the microtome to the left side until the stop. This way, the clutch on the right side of the microtome becomes free.
- Move the microtome forwards and remove it from the cryo-chamber.
- Thoroughly clean and wash the interior.



**Caution:**

Chloric cleaning agents must not be used for cleaning purposes. In case of a malfunction hazardous gases might be generated together with the cooling brine Tyfoxit of the cooling system.

- Pull off the red stopper at the bottom of the chamber. The cleaning liquid is collected in the container (fig. 26.1) with a volume of 4,8 l at the front lower side



**Note:**

Please observe the filling level!!

- The red stopper must be inserted after cleaning as otherwise cold air leaks out during cooling operation. Thus generating frost built-up.
- The installation and re-setting up of the instrument is carried out in reverse order.

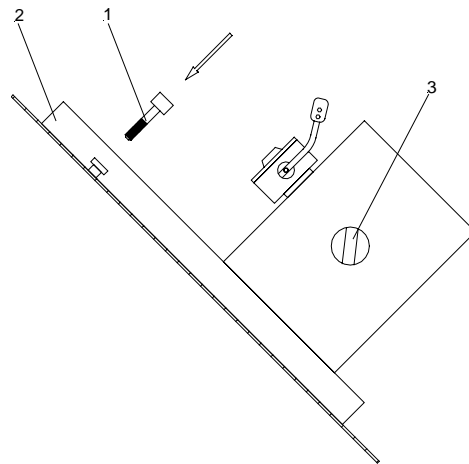

Fig. 25



Fig. 26

### 5-3 CLEANING AND CARE OF THE MICROTOME

- Carefully clean and dry the dismantled microtome.
- Carefully clean and dry the dismantled knife carrier as well.
- As there is condensed humidity inside the microtome, dry the microtome components inside the cooling chamber very carefully.
- For this, the microtome can be treated in a drying closet at temperature up to +60°C.
- After each shutting-off or cleaning of the cryostat, the cross roller bearing should be lubricated.
- By means of a pipette (fig. 27.3) the cross roller bearings (fig. 27.4) can be reached from an angle from behind below the housing (fig. 27.1).
- Fill the pipette with a small amount of cryostat oil (cat. no. 350040).
- Put one or two drops into the space (fig. 27.2) of the cross roller bearings.
- The specimen clamping should be in the lower position.
- Also slightly lubricate the horizontal cylinder guide behind the specimen clamping.

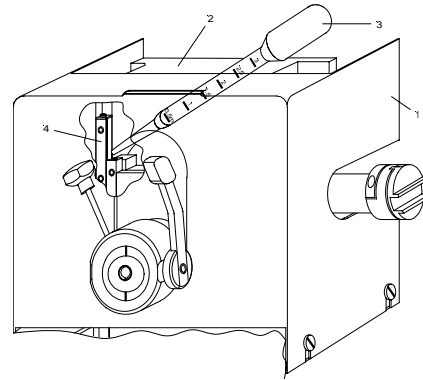

Fig. 27



#### Note:

For the examination and re-adjustment of the microtome a routine maintenance should be performed by trained service technician once a year.

#### Cleaning and care of the microtome during routine work:



#### Caution!

A regular and/or immediate disinfection of the blade carrier, the cryo chamber as well as all the other potentially contaminated parts of the instrument is highly recommended. All commercially available cryostat disinfection solutions can be used.

## 5-4 CLEANING THE COOLING LAMELLA

- Open the cleaning opening via the attached tool (fig. 29.1).
- For this, insert the tool through one of the middle ventilation slots.
- Turn the tool by 90° so that the t-shaped holder latches into the adjacent slots.
- Pull the tool to open the grid (fig. 28.1) of the cleaning hole.



**Note:**

The grid of the cleaning hole is kept on the right side by a magnet (fig. 28.2) and is inserted on the left side.

- Remove the dust from the cooling lamella by means of a commercially available vacuum cleaner.



**Note:**

Carry out this cleaning in regular intervals. Thus extending the lifetime of the compressor.

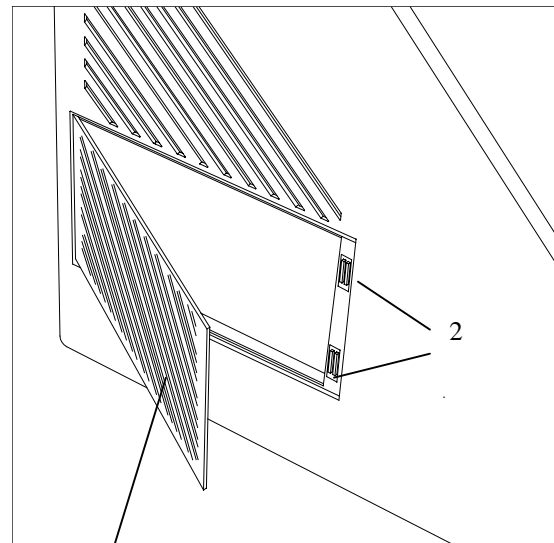

Fig. 28

1

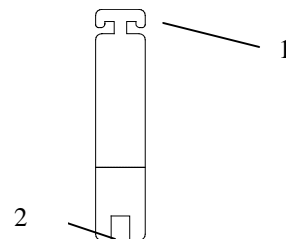

Fig. 29

## PART 6 CONDITIONS FOR THE TRANSPORTATION OF THE INSTRUMENT

### 6-1 TAKING BACK THE INSTRUMENT FOR REPAIR OR ROUTINE MAINTENANCE

Repair or maintenance work are normally carried out at the site of installation. If this is not possible for some special reasons, the instrument can be returned to MICROM. The contact address can be found at the beginning of this instruction manual.

- To guarantee trouble-free function of the instrument after transportation, please note the below-mentioned measures for the transportation preparation.
- In addition, the conditions for storage and transportation as mentioned in part 1-2 must be observed during the entire transportation.

#### **Biohazard:**



Please also note the precautionary measures described in our safety precautions concerning biological hazards!

#### **Measures for closing down:**

- Turn off the instrument.
- Unplug the unit.
- Remove blade and/or knife from blade and/or knife carrier.
- Remove section waste trays, brush shelf, blade/knife carrier and other accessories as well as tools from the cryo chamber.



#### **Note:**

Clean and disinfect these accessories according to the respective applicable lab regulations and transport them in dry condition.

- Clean and disinfect the cryo chamber according to the respective applicable lab regulations.
- Unscrew the handwheel handle for transportation.
- Before the transportation, loosen the fastening screws of the rollers.
- Keep the heated sliding window closed during transportation.



**Note:**

If the new site of installation can be reached in less than half an hour, keep the sliding window closed so that the cryo chamber does not heat up. This avoids the formation of condensation water inside the chamber.



**Note:**

It is recommended that at least two persons are available for the transportation.

**Measures for turning on again:**

- Again install the blade carrier, section waste trays and the brush shelf.
- Attach the handwheel handle again.
- After having turned on the instrument and after having reached the set temperature, the instrument is ready of operation again.



**Note:**

Blade carrier which was heated up to ambient temperature, needs approx. 1 h in the chamber at  $-25^{\circ}\text{C}$  to be able to section specimens again.

**For transportation outside closed buildings, please observe the following measures:**

- Turn off the instrument.
- Unplug the unit.
- Remove blade and/or knife from blade and/or knife carrier.
- Remove section waste trays, brush shelf, blade/knife carrier and other accessories as well as tools from the cryo chamber.



**Note:**

Clean and disinfect these accessories according to the respective applicable lab regulations and transport them in

dry condition.

- Clean and disinfect the cryo chamber according to the respective applicable lab regulations.
- Unscrew the handwheel handle for transportation.



**Note:**

To make sure that there is no condensation water inside the chamber, let the instrument approx.

48 h dry.

- Loosen the fastening screws of the rollers to move the instrument.
- Arrange the dismantled accessories into the intended transportation packing.



**Note:**

Before the further transportation, tighten the fastening screws so that the instrument does not move during

transportation.

- Slightly tilt the cryostat and insert the foam parts underneath it.
- Place the case over the instrument.
- Insert the wooden cover.
- Attach the tightening strips around the packing.

## 6-2 DISPOSAL OF THE INSTRUMENT AFTER FINAL SHUTDOWN

After the final shutdown of the instrument, we recommend to contact a local recycling company for the disposal according to the national applicable regulations.



**To be applied in the countries of the European Union and other European countries with a separate collecting system within the waste management.**

The marking of the product and/or the respective literature indicates that, after its final shutdown, it must not be disposed of together with ordinary domestic waste.

- Please dispose of your instrument separately from other waste to not harm our environment and/or human health by uncontrolled waste disposal.
- Recycle your instrument to support the sustainable recycling of material resources.
- **Industrial users** should contact their suppliers and observe the conditions of the contract. This product must not be disposed of together with other commercial waste.
- **Please contact your supplier!!**