

MICROTOME CRYOSTAT

Cryo-Star HM 560 M

INSTRUCTION MANUAL

CERTIFICATION

MICROM International GmbH certifies that this instrument has been tested and checked carefully. Its technical data was verified before shipment to be in accordance with the published specifications.

The instrument complies with applicable international safety regulations.

WARRANTY

This MICROM product is warranted against defects in material and workmanship for a period of 1 year. Parts which prove to be defective during the warranty period will be repaired or replaced free of charge by MICROM International GmbH. No other warranty is expressed or implied. Unauthorized modification or repair by third party persons will void the warranty.

The warranty will expire in case of improper or wrong use of the instrument and in case the warning and precautionary messages are not observed. MICROM International GmbH is not liable for any occurring damage.

Errors and omissions excepted. Subject to amendment and improvement without further notice.

This instruction manual will be supplied together with each instrument. Further copies can be ordered at the nearest MICROM sales office by giving the serial number of the instrument, the number of the instruction manual and the date of issue.

This instruction manual is available in the following languages:

	Cat. No.
German:	387 360
English:	387 370
French:	387 480

INTENDED USE

Dear Customer,

Before putting the instrument into operation, please read these operating instructions carefully to familiarize yourself with its proper operation and functions.

Only skilled or specially trained personnel must operate the microtome cryostat, i.e. clamping the specimen, trimming, sectioning and taking off the sections from the instrument. The listed and marked safety measures as well as the regulations and hygiene measures of your respective lab must strictly be observed.

MICROM Ser. No. :.....

Please check the MICROM Ser. No. on the type plate, which is placed on the rear side of your instrument and enter this number here. This way, questions and service can be handled faster.

Instruction Manual No. 387370

Issued on April 25, 2006

MICROM International GmbH Robert-Bosch-Strasse 49
--

D-69190 Walldorf

Telefon: (06227) 836-0 Telefax: (06227) 836-111
--

Intended Use

Table of Contents

EC Certificate of Conformity

Safety Precautions

PART 1 INTRODUCTION

- 1-1 Description of the Cryo-Star HM 560 M
- 1-2 Technical data Cryo-Star HM 560 M

PART 2 OPERATING INSTRUCTIONS

- 2-1 Setting up the cryostat
- 2-2 Initial turn-on
- 2-3 Basic operational rules
- 2-4 Setting section thickness and trimming thickness
- 2-5 Specimen and knife cooling
 - 2-5-1 Actual and set value of the specimen temperature
 - 2-5-2 Actual and set value of the knife temperature
 - 2-5-3 Function fast freezing
 - 2-5-4 Programming temperature parameters
- 2-6 Cutting movement and retraction
- 2-7 Feed
 - 2-7-1 Knife carrier coarse feed
 - 2-7-2 Speed of the knife carrier coarse feed
 - 2-7-3 Automatic approach system
 - 2-7-4 Trimming and first cuts
 - 2-7-5 Fine feed
- 2-8 Motorized cutting drive
 - 2-8-1 Setting the cutting window
 - 2-8-2 Selecting the operating modes
 - 2-8-3 Setting the cutting speed
 - 2-8-4 Start and stop of the cutting drive
 - 2-8-5 Handwheel brake
 - 2-8-6 Emergency stop
- 2-9 Detaching the specimen
- 2-10 Indication of cutting processes
 - 2-10-1 Section counter
 - 2-10-2 Section thickness sum
 - 2-10-3 Remaining travel to front end position
 - 2-10-4 Real time

- 2-11 Setting the real time, WAKE time and ACTIVE time
 - 2-11-1 Setting the real time
 - 2-11-2 Setting the WAKE time
 - 2-11-3 Setting the ACTIVE time

- 2-12 Defrosting
 - 2-12-1 Setting the defrost time
 - 2-12-2 Defrosting cycle
 - 2-12-3 Interrupting a defrosting cycle

- 2-13 Turning off the function retraction

- 2-14 Customer-specific settings
 - 2-14-1 Setting the contrast
 - 2-14-2 Selecting the language

- 2-15 Turning off the cooling function

- 2-16 Illumination of the cooling chamber

- 2-17 Adjusting the operating panel

- 2-18 Specimen holder, freezing-on and specimen orientation
 - 2-18-1 Specimen holder, freezing-on
 - 2-18-2 Specimen orientation

- 2-19 Knife carriers
 - 2-19-1 Standard knife carrier SM
 - 2-19-2 Disposable blade holder SE
 - 2-19-3 Modification from standard knife carrier SE to disposable blade holder SE

- 2-20 Error code indication
 - 2-20-1 Definition of the error codes

- 2-21 Accessories
 - 2-21-1 Standard equipment
 - 2-21-2 Additional equipment

PART 3 Theory of operation

- 3-1 Specimen and knife carrier cooling, defrost cycle
- 3-2 Cutting movement
- 3-3 Knife carrier coarse feed and trimming stages
- 3-4 Automatic approach system
- 3-5 Motorized cutting drive

PART 4 Working with the cryostat

- 4-1 Preparations on the microtome and inside the cooling chamber
- 4-2 Freezing on the specimen
- 4-4 Orientation and trimming of specimens
- 4-5 Sectioning and taking off sections
- 4-6 How to avoid malfunctions

PART 5 Maintenance of the cryostat

- 5-1 Shutting-off for cleaning
- 5-2 Cleaning and care of the microtome
- 5-3 Changing the fluorescent lamp
- 5-4 Disposal of the instrument after final shutdown

EC Certificate of Conformity

Name and address of the manufacturer: MICROM International GmbH
Robert-Bosch-Straße 49
D-69190 Walldorf

Product designation: Microtome Cryostat
Type reference: HM 560 [XY]

Notification to Competent Authorities:

These medical device have been registered with the German authority as "Microtomes" under the EDMA-classification code: 23-06-02

The designated product complies with the laid down regulation:

**DIRECTIVE 98/79/EC OF THE EUROPEAN PARLIAMENT AND OF THE COUNCIL
of 27 October 1998
on in vitro diagnostic medical devices**

The designated product complies with the EC regulations by strictly observing the following norms:

DIN EN ISO 14971:2001-03

Medical devices - Application of risk management to medical devices (ISO 14971:2000).

DIN EN 61010-1:2002-08

Safety requirements for electrical equipment for measurement, control and laboratory use - Part 1: General requirements (IEC 61010-1:2001).

DIN EN 61010-2-101:2003-09

Safety requirements for electrical equipment for measurement, control and laboratory use - Part 2-101: Particular requirements for In-Vitro-Diagnostic-(IVD)-Medical instruments.

DIN EN 61010-2-081:2002-12

Safety requirements for electrical equipment for measurement, control and laboratory use - Part 2-081: Particular requirements for automatic and semi-automatic laboratory equipment for analysis and other purposes (IEC 61010-2-081:2001).

DIN EN 61326:2002-03

Electrical equipment for measurement, control and laboratory use - EMC requirements (IEC 61326-1:1997 + A1:1998 + A2:2000); German version EN 61326:1997 + A1:1998 + A2:2001

DIN EN ISO 9001:2000

Quality management systems - Requirements (ISO 9001:2000)



Hans Heid
Managing Director

Walldorf, 10 February 2004

SAFETY PRECAUTIONS

WARNING SIGNALS AND SYMBOLS

The installation and routine use of the Cryo-Star HM 560 M is easy and safe if the instructions in this manual are being observed.

However, the situations which might be risky for the personnel or equipment are specially marked in this manual with the following symbols and messages.



Note:

Special instructions regarding operation of the instrument.



Caution:

Special precautionary measures to prevent damage to equipment. For a long lifetime of the equipment, please observe these instructions carefully.



Danger:

Special warning messages to prevent harm to persons and/or serious damage to equipment. For your own safety, please observe these instructions carefully.



Biohazard:

Warning of biological danger.



Separate taking back of electrical and electronic instruments in the countries of the European Union:

This is to be applied in the countries of the European Union and other European countries with a separate collecting system within the waste management.

This product, being an electro and/or electronic instrument, must be treated separately within the waste management process (WEEE).

ATTENTION!

Please observe the following general precautions during operation of this instrument. Failure to comply with these precautions violates safety standards and the intended use of the instrument. MICROM International GmbH is not liable for misuse of the instruments and failure to comply with basic safety requirements.

INSTRUMENT GROUNDING

To avoid injury from electrical current, the instrument must be connected with the safety ground. The instrument is equipped with a three wire ground plug. The power outlet must be connected to the safety ground and must meet the International Electrotechnical Commission (IEC) regulations.

CAUTION: MAINS VOLTAGE

Never remove instrument covers during operation. Component replacements as well as adjustments must only be made by trained service personnel. Unplug the unit before removing or opening the covers.

DANGER IN EXPLOSIVE ENVIRONMENT

The instrument must not be operated in the presence of flammable gases.

HAZARD OF FROSTBITE

Avoid permanent touching of metal parts inside the cryostat microtome chamber, as frostbite may occur at unprotected hands and arms.

HAZARD OF RADIOACTIVE RADIATION

When working with radioactive specimens observe all applicable radiation safety procedures. When working with radioactive contaminated material, appropriate safety and disinfection measures must be carried out. According to the rules and regulations concerning the handling of radioactive contaminated material of the respective laboratory, safety clothing (e.g. particle mask, gloves, protective shoe covers) must be worn. Radioactive contaminated waste must be disposed of according to the respective regulations.

HAZARD OF INFECTION

Use the appropriate safety and disinfection measures when working with infectious specimens. According to the rules and regulations concerning the handling of infectious/radioactive contaminated material of the respective laboratory, safety clothing (e.g. particle mask, gloves, protective shoe covers) must be worn.

CARE IN USING MICROTOME KNIFE

To diminish the danger of being injured by the knife or blade, use the knife guard when adjusting specimen and knife. If possible, the specimen should be clamped in before the knife is inserted into the knife holder. Before changing the knife holder, always remove blade or knife! Unused knives should always be kept in a knife case. Never place the knife with the cutting edge upwards. Never try to catch a dropping knife!! Never check the sharpness of the cutting edge with your fingers. The cutting edge is extremely sharp!

CAUTION: DANGER OF SQUEEZING

When placing the microtome cryostat HM 560 M onto the height adjustable stage, it is absolutely necessary that the stage is in its upper position or in case of a mechanical stage that the rear wall will be removed. Not observing this leads to the risk of squeezing your hands between the rear carrying handles and the stage housing.

HAZARD OF BIOLOGICAL DANGER

Specimens used during the intended operation of the instrument might potentially be infectious. For this reason, it is recommended to observe the general laboratory regulations concerning protection against danger of infection. Information on decontamination media, their use, dilution and effective range of application can be read in the Laboratory Biosafety Manual : 1984 of the World Health Organization.

HAZARD OF MALFUNCTION

To avoid the hazard of malfunction of an instrument, it must only be operated in a controlled electromagnetic environment. This means, that transmitters such as mobile phones must not be operated in their close vicinity.

WASTE DISPOSAL

All debris, waste as well as infectious and radioactive contaminated material from operation must be disposed of in accordance with the respective regulations of the lab. Disinfection and cleaning liquids as well as section waste must be disposed of according to the respective regulations for special waste!

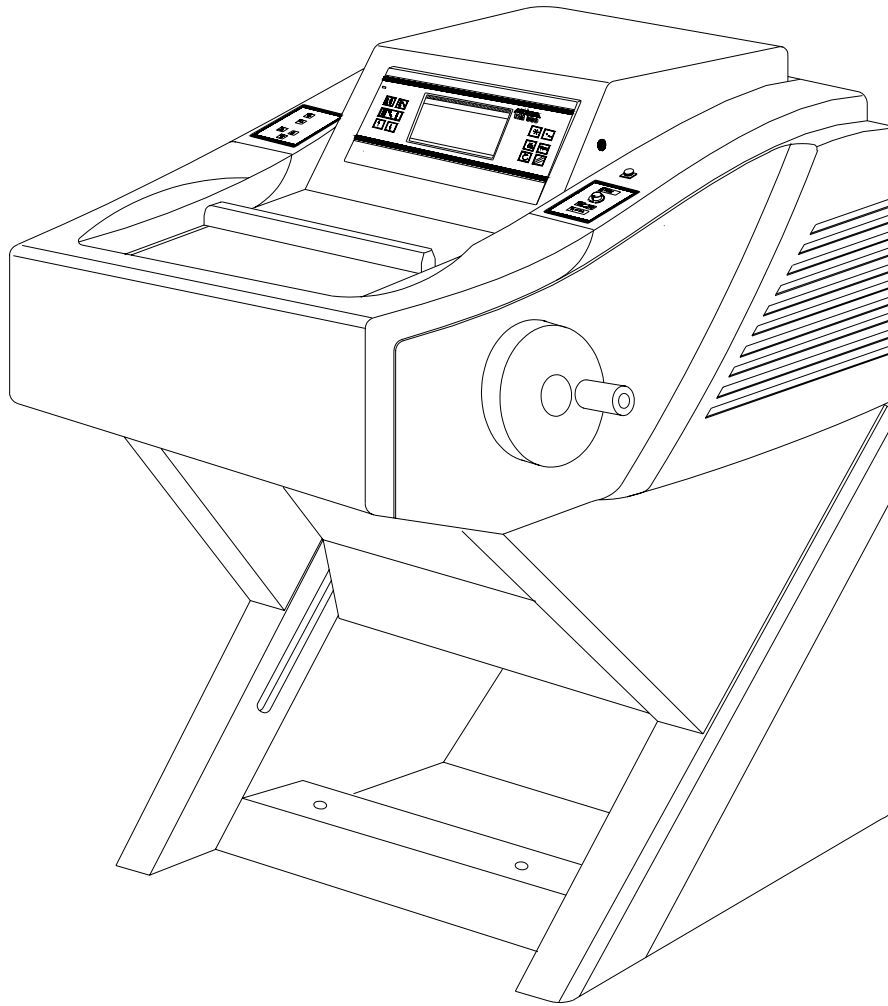

Fig. 1

1 INTRODUCTION

**1-1 DESCRIPTION OF THE
CRYO-STAR HM 560 M**

Open top cryostat. Modular design. Stainless steel cooling chamber. Temperature regulation variable down to -50°C for specimen holder and down to -35°C for knife carrier. Graphic LC-display of preset and actual temperatures, electronic control with user-oriented touchpad keyboard, battery-buffered memory and self-diagnostic system. Standby and sleep status for noise reduction and energy savings. Automatic evaporator defrosting and in addition a manual defrost cycle which can be activated when needed. Defrost interrupt on keystroke request. Integrated rapid freezing device with controlled cooling element down to -60°C. Freezing device temperature independent of cryo-chamber temperature. Detach function to remove used specimen from specimen chucks. Sliding window with heater and integrated, position adjustable fluorescent lamp for cryo-chamber. Storage space inside the cryo-chamber. Flat storage space on top of the housing.

HM-Rotary Microtome with backlash and maintenance-free cross roller bearings in stainless steel. Electro-motorized feed system. Section thickness setting from 0,5 to 100 microns; up to 2 µm in 0,5 µm-increments, up to 10 µm in 1 µm-increments, up to 20 µm in 2 µm-increments, up to 50 µm in 5 µm-increments and up to 100 µm in 10 µm-increments.

Trimming thickness setting from 5 to 500 microns; up to 10 µm in 5 µm-increments, up to 100 µm in 10 µm-increments, up to 200 µm in 20 µm-increments and up to 500 µm in 50 µm-increments.

Specimen retraction during the return stroke with optical indication. Horizontal feed range 48 mm. Vertical specimen stroke 60 mm. Max. specimen size 75 x 55 mm.

Motorized coarse feed in two directions with three speed selections. Limit indication and automated switch off at front and rear limits of horizontal travel. Automatic approach system for exact and safe approach of specimen towards the knife edge.

Section counter and indication of sum of section thicknesses with reset-button. Indication of remaining travel.

Handwheel brake in any position. Fine orientation of specimen on two axes. Rotatable on Z-axis, 360°.

Basic outfit with three specimen chucks, cryo-compound, 100 ml cryostat oil, brush shelf and section waste tray.

Electric motor drive with electronic control of the cutting stroke. Cutting speed variable from 0 to 250 mm/s. Accelerated return travel. Freely selectable cutting zone with automated function. Three modes of operation: interval, single and continuous stroke. Indication of handwheel brake. Manual control of motor drive via safety start procedure. Stop command selection via manual control, foot pedal or handwheel brake. Emergency stop key and foot pedal emergency stop.

A multi-use knife carrier is available. The standard knife carrier is designed so the knives as well as the disposable blade holder can be easily clamped in place and adjusted.

Depending on the version, the disposable blade holders SE take up low or high profile blades. The corresponding anti-roll guides facilitate taking off sections.

1-2

TECHNICAL DATA CRYO-STAR HM 560 M

Specimen temperature control: +10°C to -50°C
 Knife carrier control: -10°C to -35°C
 Fast freezing station:down to -60°C

Defrosting: automatic defrosting, adjustable with temperature control
 manual immediate defrosting

Microtome: Section thickness range: 1 - 500 µm

Fine section thickness range:..... 0,5 - 100 µm
 Resolution: 0,5 µm for 0,5 - 2 µm
 1 µm for 2 - 10 µm
 2 µm for 10 - 20 µm
 5 µm for 20 -50 µm
 10 µm for 50 - 100 µm

Trimming thickness range: 5 - 500 µm
 Resolution: 5 µm for 5 - 10 µm
 10 µm for 10 - 100 µm
 20 µm for 100 - 200 µm
 50 µm for 200 - 500 µm

Knife carrier retraction during return travel40 µm
 Horizontal knife carrier range 48 mm
 Vertical specimen stroke 60 mm

Read-outs: Graphical LC display: section thicknesses, section counter, sum of section thicknesses, remaining travel to front end position, size of the cutting window

Specimen approach: automatic function
 alternatively manual with variable speed

Temperature parameter: temperature set values can be stored in pairs

Size of chucks:30, 40 mm
 special sizes upon request

Specimen orientation: x - and y - axes: universal 8°
 z - axis: up to 360°

Coarse feed: motorized, graduated and continuous

Cooling chamber illumination: with variable illumination position
 Sliding window:heated

Cutting drive: manual and motorized, electronically controlled
 Cutting window speed: autom. cutting window adjusted to specimen size
 Operating modes: interval, single and continuous stroke
 Cutting speed:0 - 250 mm/s

All temperatures refer to an ambient temperature of +20°C!

Cont'd on page -2-

1-2

TECHNICAL DATA CRYO-STAR HM 560 M

Handwheel brake:in any position
 Emergency stop:via handswitch or foot pedal

Storage temperature range: -20°C up to +50°C

Operating conditions: +5°C up to +35°C (at a max. rel. humidity of 60%)
 altitude up to 2000 m M.S.L.
 for indoor use only

Power requirements: 100 V 12 A +/-10% 50...60 Hz
 115 V/ 12 A +/-10% 60 Hz
 220...230 V 6 A +/-10% 50...60 Hz
 240 V 6 A +/-10% 50 Hz

Pollution degree:2
 Overvoltage category:II
 Acoustic pressure: 45 dB(A)
 measured with 1 m distance to the instrument

Dimensions: ... Wide (w/o handwheel): 769 mm, deep: 932 mm, high: 578 mm

Weight: 145 kg

All temperatures refer to an ambient temperature of +20°C!

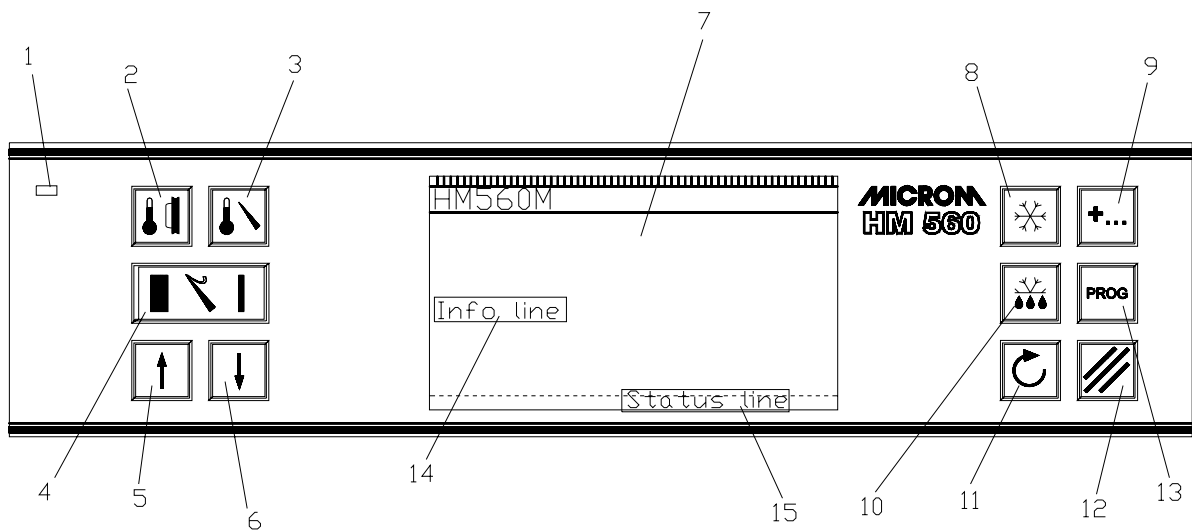

Fig. 2

- 1 = On indication (sleep status)
- 2 = Button specimen temperature
- 3 = Button knife temperature
- 4 = Button TRIM/FEED
- 5 = Button UP
- 6 = Button DOWN
- 7 = LC display
- 8 = Button fast freezing

- 9 = Button options
- 10 = Button detaching
- 11 = Scroll button
- 12 = Button RESET
- 13 = Button PROG
- 14 = Info line
- 15 = Status line

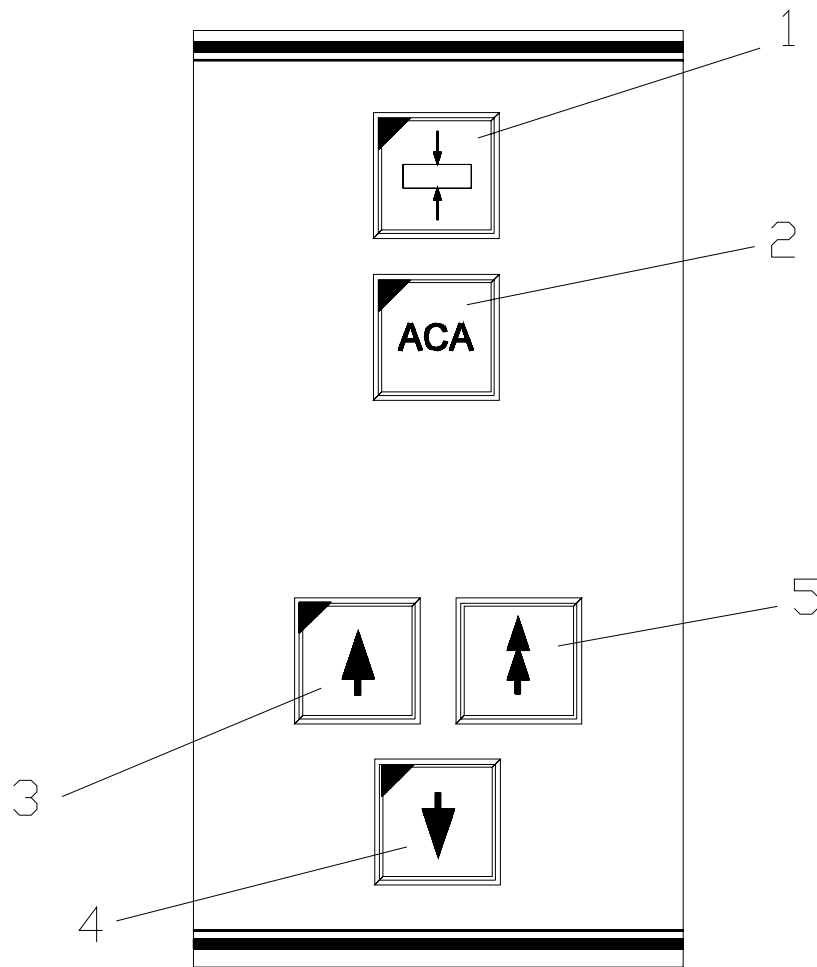

Fig. 3

- 1 = Button cutting window
- 2 = Button ACA
- 3 = Button coarse feed, forwards
- 4 = Button coarse feed, backwards
- 5 = Button TRIM

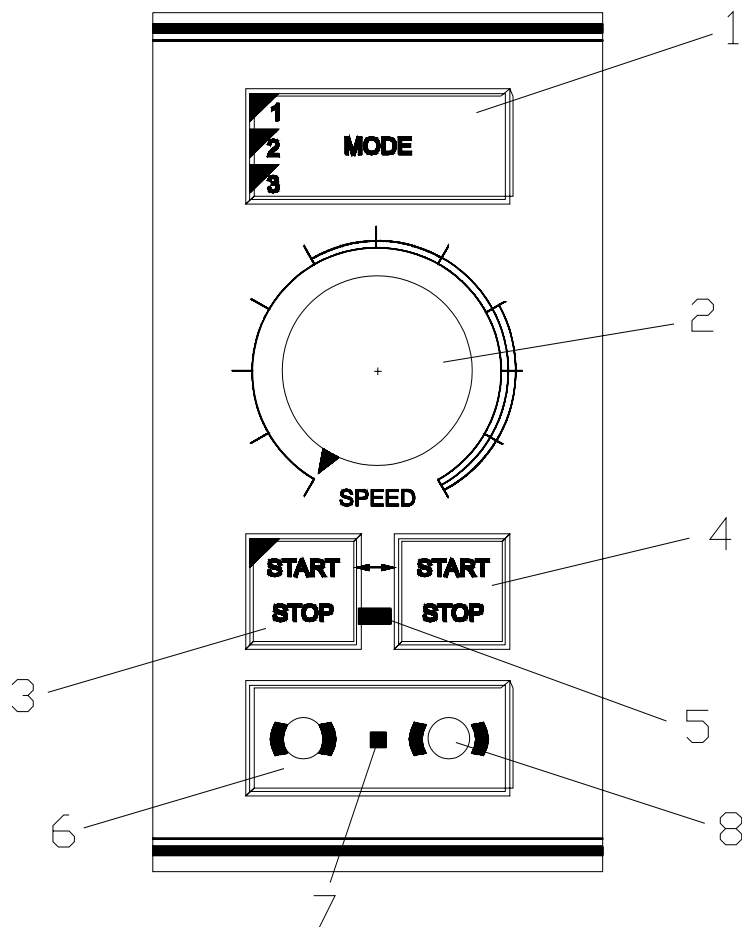

Fig. 4

- 1 = Button operating modes
- 2 = Operating knob
- 3 = Button START/STOP
- 4 = Button START/STOP
- 5 = Emergency-Stop LED
- 6 = Button to activate the handwheel brake
- 7 = Brake LED
- 8 = Button to loosen the handwheel brake

2 OPERATING INSTRUCTIONS

2-1 SETTING UP THE CRYOSTAT



Note:

If the microtome cryostat is supplied with an extra height-adjustable stage, first unpack and set up this stage according to the separate instruction manual.

Unpacking the instrument:

- Loosen and remove the four tightening straps.
- Lift and remove the wooden top of the packing.
- Remove the foam parts upwards.
- The four side parts of the packing, which are connected with each other, can now be removed upwards.
- Slightly tilt the cryostat to the side and remove the right and left lower foam parts one after the other.
- Lift the cryostat by the carrying handles (fig. 5.1 and 5.2) from the pallet.
- In case the handles are not installed, securely install the attached carrying handles (fig. 5.1 and 5.2) at the front and rear side of the instrument and carry the instrument to the site of installation (table according to the customer's choice) or place it onto the height-adjustable stage.

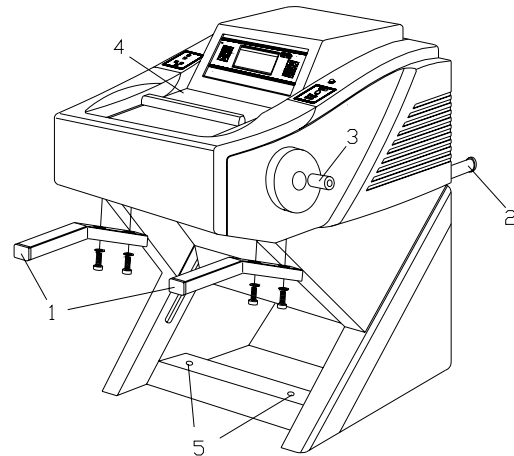

Fig. 5



Danger:

When placing the microtome cryostat HM 560 M onto the height-adjustable stage, it is absolutely necessary that the stage is in its upper position. Not observing this leads to the risk of squeezing your hands between the rear carrying handles and the stage housing.

- Remove the handles (fig. 5.1 and 5.2).



Caution:

Before the initial set-up of the height-adjustable stage, it is absolutely necessary to dismount the two rear carrying handles (fig. 5.2) on the cryostat, as when lowering the height-adjustable stage, the handles will hit the stage and cause damage to the stage.

- Adjust the handles of the cryostat (fig. 5a.1 and 5a.2) on the rear side of the cryostat stage.
- Carefully keep the shipping container for possible return shipments.

Choose installation site that

- enough ventilation for the cooling system is guaranteed.
- the distance between wall and rear panel is approx. 10 - 15 cm.
- the suction areas on either side are kept free.

Moreover, the installation site must be free from:

- draught by open doors or by air conditioning systems.
- direct exposure to sunlight into the cooling chamber.



Note:

Both measures reduce the formation of frost and therefore result in more favourable work conditions. A high air moisture as well as high ambient temperatures reduce the maximum performance of the instrument.

In case the instrument is equipped with the height-adjustable stage, turn the screws (fig. 5.5) on the front foot ends to fix the complete unit.

Afterwards:

- Install the attached handwheel handle (fig. 5.3) and
- Connect the attached foot pedal to the socket (fig. 6.4) on the rear panel of the instrument.

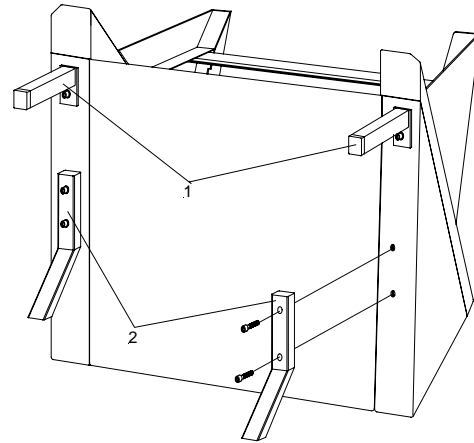

Fig. 5a

2-2 INITIAL TURN-ON

As already mentioned in part 2-1, the height-adjustable stage, if equipped, must be set up according to the separate instruction manual before the initial turn-on of the microtome cryostat.



Caution:

Before turning on the instrument for the first time, please check if the power requirements indicated on the type plate (fig. 7) correspond to the power supply voltage being used.

- No other instruments should be connected to the circuit used for the cryostat, as the compressor needs high surge currents when started.
- Do not use multi-socket power outlets and extension lines for the supply of the stage.
- Connect the power line of the instrument to the power outlet.
- Plug in the foot pedal into the respective socket (fig. 6.4).



Note:

If the foot pedal is not connected, there is the operating mode emergency stop (see part 2-8-6). This way, the handwheel brake is activated and the cutting drive motor cannot be started. Always connect the foot pedal!

- Turn on the power switch (fig. 6.1) on the rear side of the instrument.
- Close the heated sliding window (fig. 5.4) and cool down the instrument.



Note:

To avoid frost built-up on the specimen, the specimen temperature is controlled to a temperature of +10°C until the knife has reached a temperature of -10°C.

The cooling phase will take approx. 1 to 2 h depending on the set knife temperature between -15°C and -30°C.

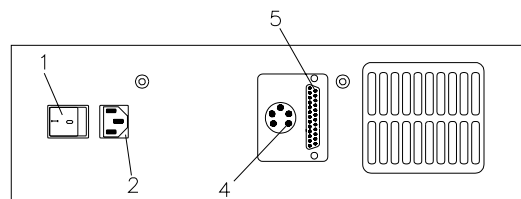

Fig. 6

- 1 = Power switch
- 2 = Mains plug
- 4 = Socket for foot pedal
- 5 = Socket for option Vacutome/Disinfection



Fig. 7

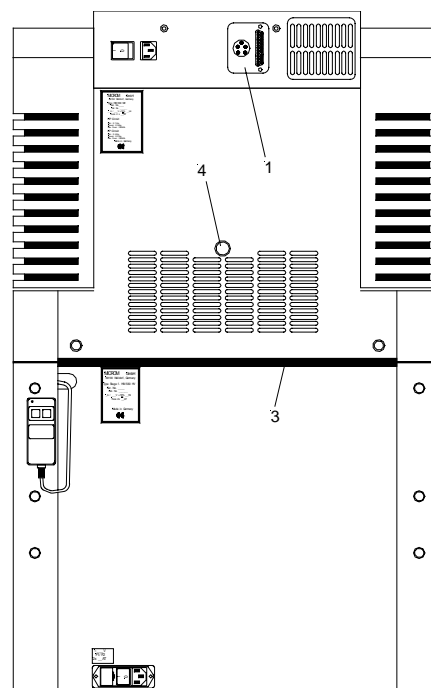

Fig. 8

2-3 BASIC OPERATIONAL RULES

When turning on the instrument, the display shows:

- the configuration of the instrument
- the section thickness selection
- the specimen and knife temperatures with the corresponding set and actual values
- the symbol for the cutting window

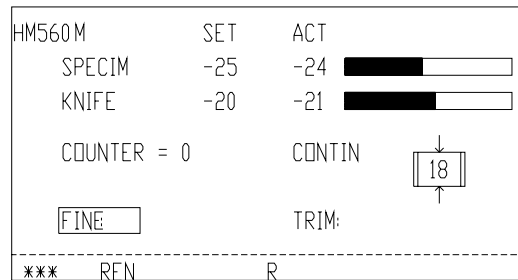

Fig. 9

This is the display (fig. 9) while the instrument is in its active status.

To save energy and extend the lifetime of some instrument components, the instrument has two more operative status:

- Standby status
- Sleep status

The instrument switches to the **standby status** when it is turned on, but not operated for more than a pre-selected active time (see part 2-11-3) between 1 and 9 h. The chamber illumination goes off and the display (fig. 10) switches to a large indication of the knife actual temperature. This is the clear sign for the **standby status** and gives the operator information on the knife temperature, also from a greater distance.

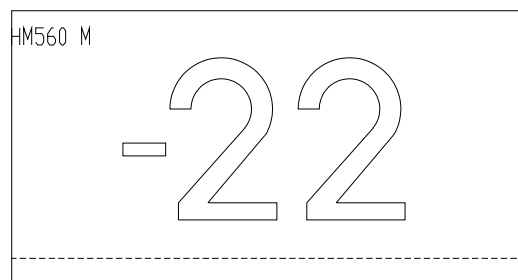

Fig. 10

When the instrument is not operated for another hour, the cryostat switches to the **sleep status**. The display illumination goes off. However, the equipment-on indicator (fig. 2.1) then lights up and shows that the instrument is still on.



Note:

While in the sleep status, the temperature control of the knife temperature features a reduced control accuracy.

The specimen temperature in the sleep status is always kept at -15°C. The set temperature of the knife carrier is kept constant.

- To return to the active operating state, press any key on the control panels, move the handwheel. Also when reaching the WAKE time (see part 2-11-2) the instrument is in the active state again.

The **WAKE** time is used to trigger the instrument back into the active state.

UP/DOWN buttons

These two buttons (fig. 11.5 and 11.6) are used to change pre-selected values of different kinds in connection with the chosen function.

- section thickness
- trimming thickness
- specimen temperature
- knife temperature
- time settings



Note:
To operate the instrument easily and comfortably with a few buttons only, please note the following:

After having chosen a function, its pre-selected values can be changed via the UP or DOWN buttons.

However, if no entry is made within 2 seconds, the operating control switches back into its basic status.

RESET-button

This button (fig. 12.4) is used to reset added values (e.g. number of sections, sum of section thicknesses) to zero. In some cases, this button is used as additional button for double-button functions (see part 2-8-1 and 2-12-4).

Keyboard lock

To lock the keyboards and to block the feed movement, press the buttons (fig. 12.4 and 12.1) for approx. 2 sec. The display (fig. 12a) shows LOCKED.

To unlock the keyboards press the buttons (fig. 12.4 and 12.1) again.

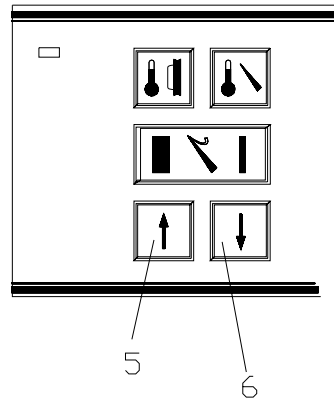

Fig. 11

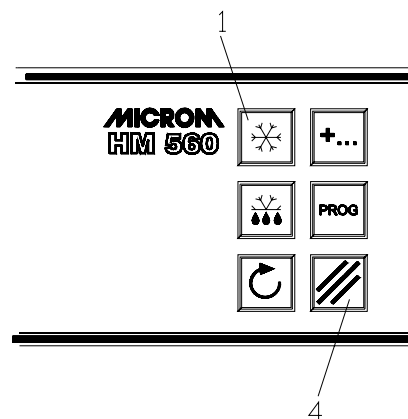

Fig. 12

HM560M	SET	ACT	
SPECIM	-25	-24	
KNIFE	-20	-21	
LOCKED			
COUNTER = 0		CONTIN	
FINE		TRIM:	
*** REN R			

Fig. 12a



Note:

When the keyboards have been locked, this leads automatically after 5 sec. to the standby status and after another 5 sec. to the sleep status.

2-4 SETTING SECTION THICKNESS AND TRIMMING THICKNESS

Basic status of the operating control:

To choose between section thickness and trimming thickness

- press button (fig. 14.4).
- The selected setting is shown inverted on the display.
- Then enter the desired section or trimming thickness via button UP (fig. 14.5) or DOWN (fig. 14.6).
- The changed values are shown on the display.

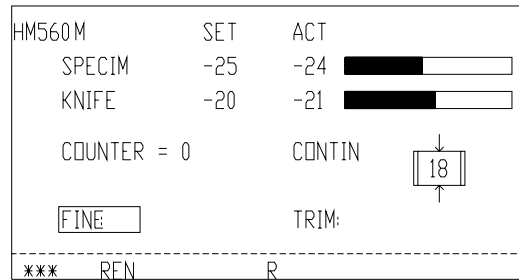

Fig. 13

The graduation of the section thicknesses (which can be pre-selected) is divided into 5 ranges:

range	graduation
from 0,5 μm to 2 μm	0,5 μm
from 2 μm to 10 μm	1 μm
from 10 μm to 20 μm	2 μm
from 20 μm to 50 μm	5 μm
from 50 μm to 100 μm	10 μm

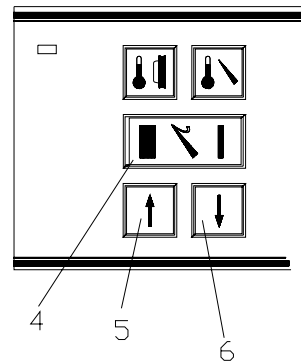

Fig. 14

The graduation of the trimming thicknesses (which can be pre-selected) is divided into 4 ranges:

range	graduation
from 5 μm to 10 μm	5 μm
from 10 μm to 100 μm	10 μm
from 100 μm to 200 μm	20 μm
from 200 μm to 500 μm	50 μm

2-5 SPECIMEN AND KNIFE COOLING

The HM 560 M makes it possible to set both the specimen and the knife temperature.

2-5-1 ACTUAL AND SET VALUE OF THE SPECIMEN TEMPERATURE

The specimen cooling of the cryostat can be controlled via the corresponding part of the operating controls (fig. 16.2).

The actual and set values of the specimen cooling are shown in °C on the display (fig. 15). On the right side of the display, the actual value is shown as on a thermometer.

- Press button (fig. 16.2) for specimen temperature.

The set value settings are made via the

- UP button (fig. 16.5)
- DOWN button (fig. 16.6)



Note:

The valid range of the set value goes from +10°C down to -50°C.

- After having chosen the requested values, the display automatically returns to its basic indications after three seconds.

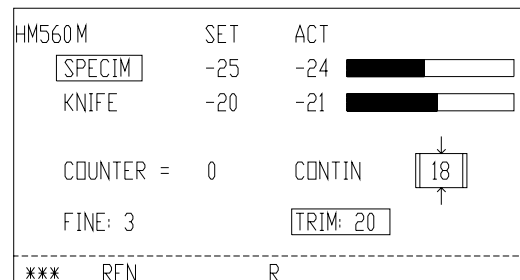

Fig. 15

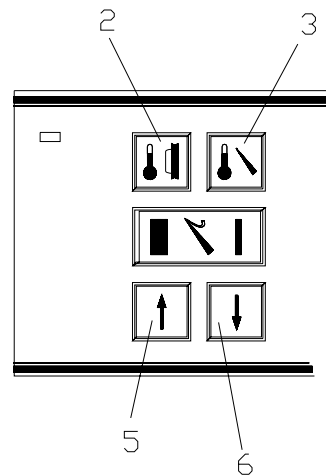

Fig. 16

2-5-2 ACTUAL AND SET VALUE OF THE KNIFE TEMPERATURE

The knife cooling of the cryostat can be controlled via the corresponding part of the operating controls (fig. 16.3).

The actual and set values of the knife cooling are shown in °C on the display (fig. 17). On the right side of the display, the actual value is shown as on a thermometer.

- Press button (fig. 16.3) for knife temperature.

The set value settings are made via the

- UP button (fig. 16.5)
- DOWN button (fig. 16.6)



Note:

The valid range of the set value goes from -10°C down to -35°C.

- After having chosen the requested values, the display automatically returns to its basic indications after three seconds.

2-5-3 FUNCTION FAST FREEZING

To accelerate freezing-on of a specimen on a specimen chuck, choose the function fast freezing. If this function is activated in due time before freezing-on, the fast freezing plate can achieve a temperature of -60°C.

- For this, press button (fig. 19.1).
- The surface in the front of the fast freezing station (fig. 59.1) will then be activated for 8 min.
- The course of the changing temperature will then be shown on the display (fig. 18) as a figure and as on a thermometer.
- Afterwards, the function *fast freezing* will automatically be inactivated.
- If it is necessary to turn off this function within those 8 min., press button (fig. 19.1) once more.

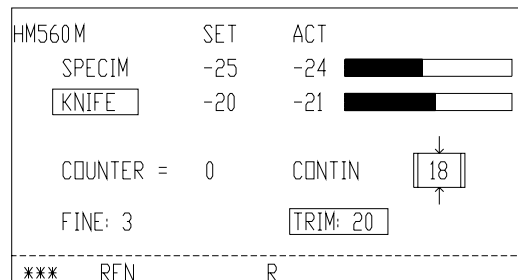

Fig. 17

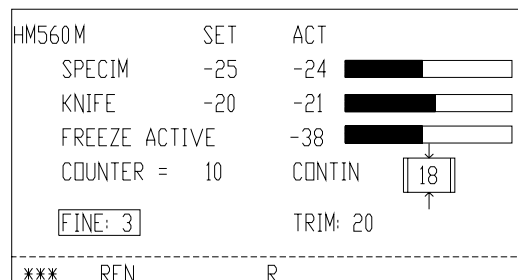

Fig. 18

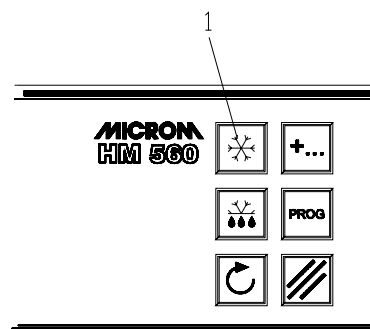

Fig. 19

2-5-4 PROGRAMMING TEMPERATURE PARAMETERS

With the cryostat HM 560 M it is possible to store four different combinations of set value temperatures for the specimen and knife temperatures. The stored temperatures are of no direct importance for the respective valid set value temperatures of knife and specimen.



Note:

The menu for the programs can only be called when the info line (fig. 2.14) is also called and values are shown. To avoid an unintended operation, see part 2-7-2.

Calling a program:

- Press button (fig. 21.3) to open the menu for the program lines.
- The first stored program appears in the info line of the display (fig. 20).
- To choose a program line, press button (fig. 21.5) until the desired program appears.
- To use the stored temperatures as set values for the active cutting status, press the UP button (fig. 22.5).
- The program line goes off and the info line appears again.
- The new set values are now shown in the *set value column* and the instrument adjusts itself to the new temperatures.

Storing a program:

- Open the menu for the programs via the button (fig. 21.3).
- Via button (fig. 21.5) call this program line which the new set value temperatures are supposed to be stored in.
- Store the actual set value temperatures into the program via the DOWN button (fig. 22.6).
- Then, the info line is shown again on the display.



Note:

If nothing is changed in the programs and they are called only for information purposes, this menu can be closed again via the button (fig. 21.4).

HM560M	SET	ACT	
SPECIM	-25	-24	
KNIFE	-20	-21	

PROG. 1	SPECIM -20	KNIFE -30	
FINE: 3		TRIM: 20	

***	REN		R

Fig. 20

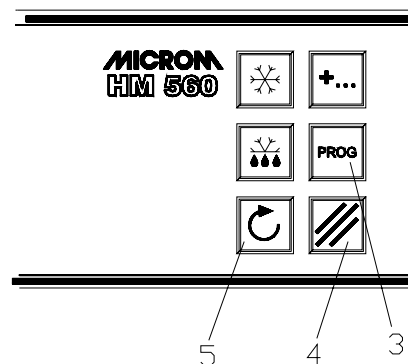

Fig. 21

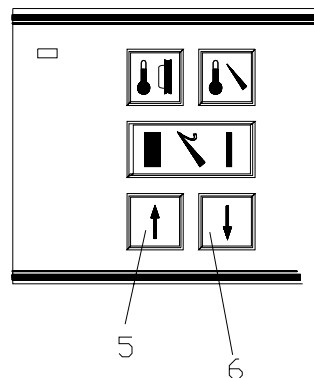

Fig. 22

2-6 CUTTING MOVEMENT AND RETRACTION

- Turn the handwheel in a clockwise direction so the cutting movement is carried out.
- As the specimen moves down, sections are produced.
- Continue turning the handwheel clockwise to bring the specimen back up.
- To protect the knife and specimen during return travel, the knife carrier is retracted electro-mechanically.
- This is shown by the letter "R" in the status line (fig. 2.15) on the display.

X=selected section thickness,
 1=specimen,
 2=cutting movement
 3=knife
 R=retraction
 F=cutting window



Caution:

When the motor drive for the cutting movement has been turned on, the same run process as above-mentioned is carried out. Keep the rotating area of the handwheel clear! Keep enough distance to the rotating handwheel handle.

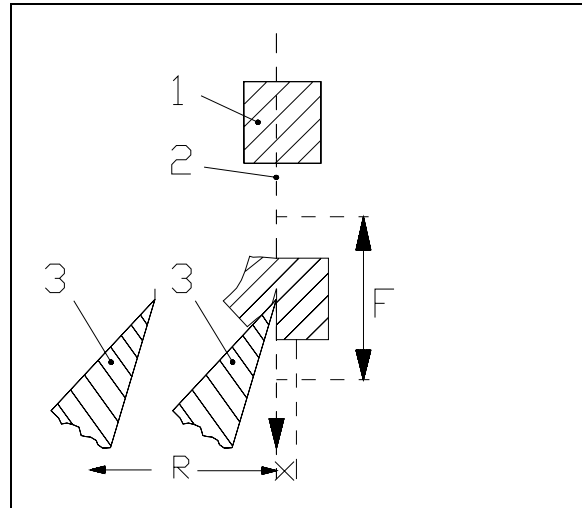

Fig. 23

2-7 FEED

2-7-1 KNIFE CARRIER COARSE FEED

For the fast forward and backward travel between knife and specimen, the cryostat microtome has a motorized coarse feed system.

The approach between knife and specimen can also be carried out by means of an automatic function (see part 2-8-2).

Return travel of the knife carrier

- Press button (fig. 24.4). Pressing the button briefly leads to short return travels only.
- Press the button (fig. 24.4) for more than approx. 2 seconds, the function is carried out continuously. The knife carrier will entirely be moved backwards.



Note:

The rear end position is defined as that position which has the longest distance to the specimen.

- To stop this function, briefly press button (fig. 24.4) once more.
- When the rear end position of the knife carrier is reached, the coarse feed turns off.
- The LED in button (fig. 24.4) blinks, which means that the knife carrier is in its rear end position.

Feed travel of the knife carrier

- The continuous forward travel is only carried out as long as the button (fig. 24.3) is being pressed.
- Press button (fig. 24.5). Briefly press this button, to carry out a forward travel of that trimming section thickness which was chosen via the control panel and shown on the display.



Caution:

With the function *coarse feed forwards* knife and specimen are adjusted very quickly. To avoid damage to specimen and knife, the following points are of utmost importance!

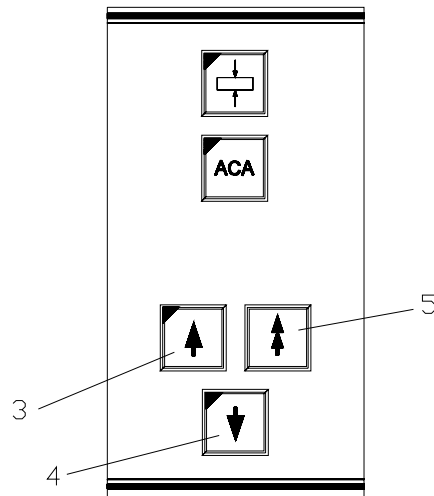

Fig. 24

- Take note that the knife edge and specimen do not come in contact with each other.
- Carefully observe the narrowing gap between knife edge and specimen to stop the function *coarse feed forwards* in time before the knife touches the specimen.

When the instrument is just carrying out the retraction movement and the function *coarse feed forwards* is selected, the coarse feed movement is carried out and the retraction is annulled.

- When the front end position of the knife carrier is reached, the coarse feed turns off.
- The LED in button (fig. 24.3) lights up and shows that the knife carrier has reached its front end position.

2-7-2 SPEED FOR KNIFE CARRIER COARSE FEED

The speed for the knife carrier coarse feed can be selected in three different settings.

The selected setting is shown in the status line (fig. 2.15) on the display by one, two or three little stars. Three stars means the fastest coarse feed setting.

Setting the speed:

- Make sure that there is no information in the info or program line. For this press the scroll button until this line is blank.
- Press button (fig. 25.3) until the desired speed is selected.
- The number of the shown stars determines the speed.

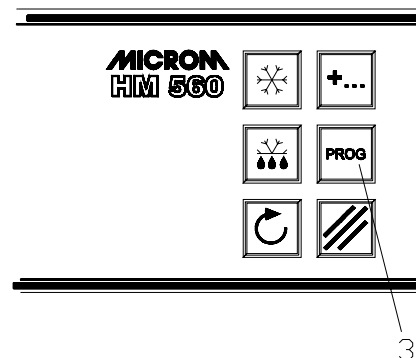

Fig. 25

2-7-3 AUTOMATIC APPROACH SYSTEM

The automatic approach system performs the fast and exact approach of the specimen towards the knife edge and can be applied between -5°C and -35°C . Beyond these temperature limits, the automatic approach system is blocked (see error code 'OUT OF TEMPERATURE').



Danger:

For your personal safety, before activating the automatic approach system, move the anti-roll plate onto the blade against possible splintering of the blade. This might be caused by an incorrect approach.



Danger:

When using different freezing techniques, for example by means of the fast freezing stations, liquid nitrogen, CO_2 and the like, which generate a freezing temperature of below -35°C , the automatic approach system can only be applied after the specimen will have adjusted itself to the respective temperature of the specimen holder which must be between the temperature range of -5°C and -35°C . As a safety measure, place the anti-roll plate onto the blade, otherwise an incorrect approach will be carried out and the blade might splinter.

Starting the automatic approach

- Use the handwheel to make sure that the most protruding point of the specimen is opposite the knife edge. This position must be within the selected cutting window.



Note:

If the button cutting window is pressed twice and the cutting window is thus inactive, the automatic approach can be released in any position.

- Press button (fig. 27.2) to start the automatic approach process.
- The red LED in this button (fig. 27.2) lights up and confirms the chosen function and AUT.APPROACH is shown in the status line (fig. 2.15) on the display (fig. 26).
- The knife carrier moves forwards until the knife edge touches the specimen.

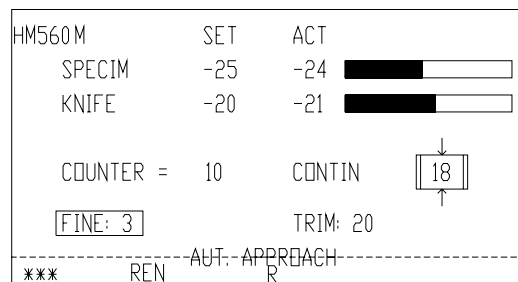

Fig. 26

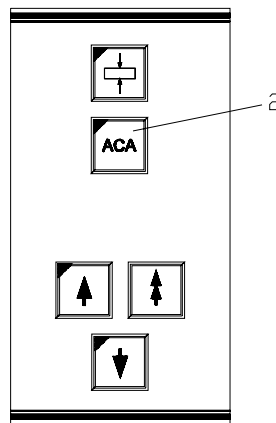

Fig. 27

- Immediately afterwards, this forward travel of the knife carrier is stopped and moved backwards by a safety distance of 200 µm. AUT.APPROACH is still shown on the display as the process of the automatic approach has not yet been finished.
- When passing the next upper reversal point, the knife carrier automatically moves forwards again by 200 µm.
- The red LED in button (fig. 27.2) goes off as well as the term AUT.APPROACH disappears.
- The specimen is now in position to start sectioning.

Cancellation of the automatic approach

- Press button (fig. 27.2) or
- pass upper or lower reversal point via handwheel.

When an automatic approach has been carried out, another approach can be started immediately, if needed.

This might become necessary, when the specimen has been oriented again.

Error codes during an automatic approach process

- **Error code 'AMPLIFIER ERROR'**
is shown on the status line (fig. 2.15) on the display, in case the activating signal for the automatic approach has already been recognized before the automatic approach movement has been started.
- Possible cause: the specimen has already been in contact with the knife edge, e.g. by protruding fibers.
- Press button (fig. 27.2), remove the cause for the error and press button (fig. 27.2) again, to start the automatic approach once more.
- However, if there is no obvious explanation for this error code, e.g. frost built-up, please call a service technician.

- **Error code 'OUT OF TEMPERATURE'** appears in the status line (fig. 2.15) on the display, if the actual temperature of the knife or the specimen is outside the temperature range of -5°C and -35°C , which is valid for the automatic approach function only.
- Press button (fig. 27.2). The error message goes off.



Note:

In this case the function *automatic approach* cannot work. The approach between knife edge and specimen must be carried out via the coarse feed button (fig. 24.3) (see part 2-7-1).

- **Error Code 'OUT OF WINDOW'** appears in the status line (fig. 2.15) on the display, if the specimen is positioned outside the cutting window.
- Press button (fig. 27.2). The error message goes off.
- Position the specimen into the cutting window or reset the cutting window to "0" and again call the automatic approach system by pressing button (fig. 27.2).

2-7-4 TRIMMING AND FIRST CUTS

After the specimen and the knife are adjusted, further gradual feed for trimming can be carried out using the function *trimming*.

For different sectioning series, deeper layers of the specimen can be reached with the function *trimming*.

- Make sure that the trimming thickness setting is selected via the button (fig. 28.4). Trimming thickness is shown inverted on the display.
- Press the button UP (fig. 28.5) or DOWN (fig. 28.6) to select the desired trimming value.
- Turn the handwheel in a clockwise direction to carry out the trimming feed in the upper reversal point of the cutting movement.

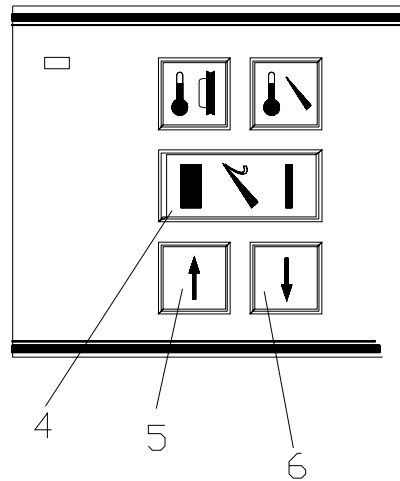

Fig. 28

2-7-5 FINE FEED

After having adjusted knife and specimen as well as having trimmed the specimen, sectioning can be started.

- Make sure that the section thickness setting is selected via the button (fig. 28.4). Section thickness is shown inverted on the display.
- Press the button UP (fig. 28.5) or DOWN (fig. 28.6) to select the desired value.
- Turn the handwheel in a clockwise direction to feed the specimen at the selected section thickness.

2-8 MOTORIZED CUTTING DRIVE

Sectioning can be carried out either manually by turning the handwheel or by means of a motorized cutting drive.

- The controlled cutting speed can be set continuously from 0 up to 250 mm/s.
- The cutting speed refers to the cutting window.
- For the upward return travel a proportionally higher retraction speed is carried out.
- To adjust the cutting window in relation to a specimen, it can be set continuously within the maximum values.

2-8-1 SETTING THE CUTTING WINDOW

The instrument automatically detects the cutting window. It is shown on the display (fig. 29) in the status line with the letters "AW" (automatic window).

The size of this window is then shown in the symbol cutting window.

When passing the cutting window this symbol is shown inverted on the display.

During this automatic function, the cutting window adjusts itself to the size of the specimen.



Note:

The automatic window is only possible within the temperature range of -5°C and -35°C. Beyond these temperature limits the automatic window turns off automatically and the manual setting is possible only.

Manual setting:

- If necessary, the cutting window can be determined by manual entries.
- For this, turn off the automatic cutting window registration. As a precondition for this process, values must be shown in the info line (fig. 2.14).
- For this, press button (fig. 30.4) and while this button (fig. 30.4) is still being pressed, press button (fig. 31.1). The letters "AW" disappear from the display.

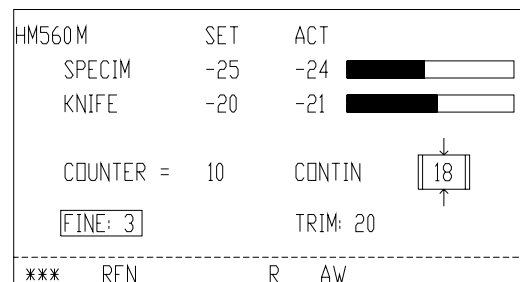

Fig. 29

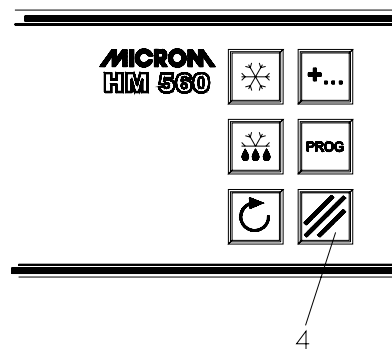

Fig. 30

- Turn the handwheel so that the lower edge of the specimen is positioned slightly above the knife edge.
- Press button (fig. 31.1) to set the upper limit of the cutting window.
- Continue turning the handwheel clockwise to place the upper edge of the specimen just below the knife edge.
- Press button (fig. 31.1) to set the lower limit of the cutting window.
- The LED in button (fig. 31.1) lights up during each further passing through of the cutting window. The length of the cutting window is shown in mm within the cutting window symbol on the display.
- To activate the automatic cutting window again, press button (fig. 30.4) and while this button (fig. 30.4) is still being pressed, also press the button (fig. 31.1).
- Then the letters "AW" are shown on the display again.

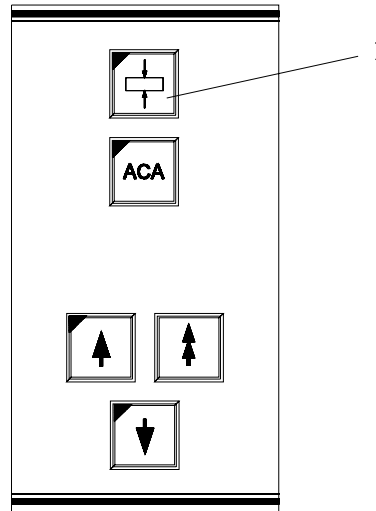

Fig. 31



Note:

A cutting window should only be set while the specimen is moved downwards. If, by mistake, a cutting window limit is set during return travel of the specimen, the set limits are applied to the cutting movement accordingly.



Note:

In case the cutting window limits are set incorrectly, please repeat above-mentioned process again.



Note:

If no cutting window is needed, briefly press the button (fig. 31.1) twice. The automatic approach system can now be released in any position.

2-8-2 SELECTION OF OPERATING MODES

For the motorized cutting movement of the microtome, the following operating modes are available:

- continuous stroke
- single stroke
- interval stroke

- If the cutting drive is turned off, choose one of the above-mentioned operating modes by pressing the button *MODE* (fig. 33.1) once or twice.
- The selected operating mode is shown on the display as CONTIN, SINGLE and INTERV and the corresponding LED in button (fig. 33.1) lights up.

Continuous stroke

- Press button (fig. 33.1) until the operating mode *continuous stroke* CONTIN is shown on the display.
- To start a continuous cutting cycle, use the foot pedal or press the two start buttons (fig. 33.3 and 33.4).
- To stop the continuous stroke, press foot pedal or one of the two start buttons (fig. 33.3 or 33.4).
- However, if a cutting cycle has been started, it will continue through and stop in the next lower reversal point.

Single stroke

- Press button (fig. 33.1) until the operating mode *single stroke* SINGLE is shown on the display (fig. 32).
- Press the two start buttons (fig. 33.3 and 33.4) or the foot pedal once to release a single cutting cycle.
- The movement stops in the lower reversal point.

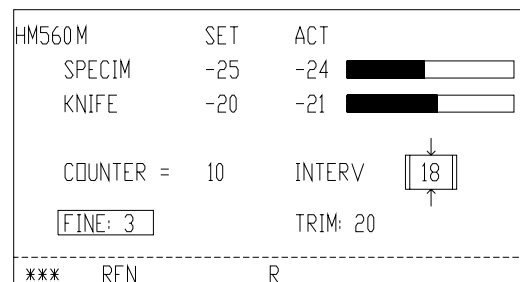

Fig. 32

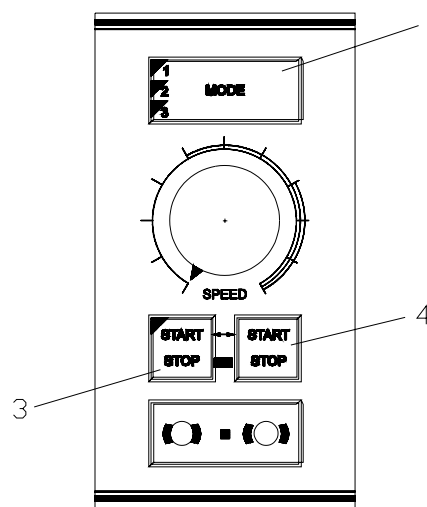

Fig. 33

Interval stroke

- Press button (fig. 33.1) until the operating mode *interval stroke* INTERV is shown on the display (fig. 32).
- The cutting drive only moves as long as the two start buttons (fig. 33.3 and 33.4) or the foot pedal are pressed.

2-8-3 SETTING THE CUTTING SPEED

- The desired cutting speed is set on the operating knob (fig. 34.2).



Note:

To save time, the return travel speed is enhanced in relation to the cutting speed, especially for slow cutting speeds.

2-8-4 START AND STOP OF THE CUTTING DRIVE

Start

- Press the two buttons (fig. 34.3 and 34.4) of the safety switch either at the same time or briefly one after the other.
- As an option, the motorized cutting drive can also be started via the foot pedal.
- The LED in button (fig. 34.3) lights up while the motorized cutting drive is active.



Note:

To start the motorized cutting drive, the functions *handwheel brake* and *emergency stop* must not be activated.

The course function of the cutting drive results from the selected cutting window, the selected operating mode and the set cutting speed (please see part 2-8-3).

Stop in operating mode continuous stroke

- Press one of the two buttons (fig. 34.3 or 34.4) or
- press foot pedal.
- The LED (fig. 34.3) goes off.

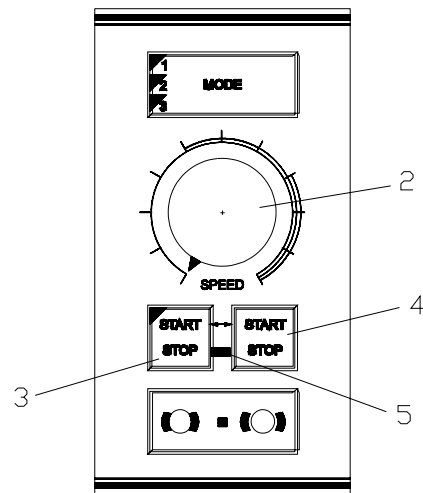

Fig. 34

2-8-5 HANDWHEEL BRAKE

Unintended movements of the specimen holder can be avoided via the handwheel brake.

This reduces the danger of being injured while adjusting specimen clamp and knife carrier!



Caution:

When the instrument is turned off, the handwheel brake is not operative.



Caution:

For your personal safety, the *handwheel brake* should be turned on when working on the specimen holder or knife carrier.

Activating the brake

- Stop the motorized cutting movement via buttons (fig. 35.3 and 35.4).
- Then activate the function *handwheel brake* via button (fig. 35.6).
- The red LED (fig. 35.7) lights up.
- The motorized cutting drive cannot be started by mistake anymore!

Releasing the brake

- To release the handwheel brake, press button (fig. 35.8).

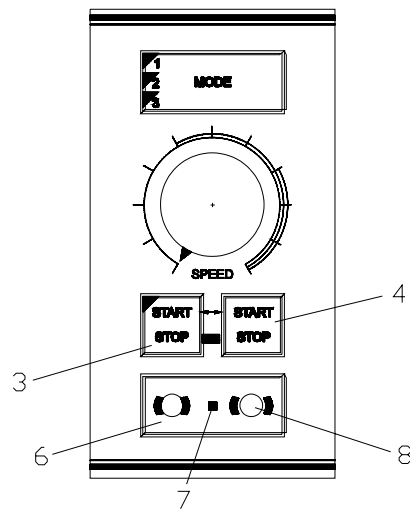

Fig. 35

2-8-6 EMERGENCY STOP

To quickly eliminate danger, the microtome is equipped with two **emergency stop** functions.



Danger:

In case danger arises from cutting drive, activate the *emergency stop!*

Hand emergency stop:

- The *hand emergency stop* (fig. 36a.2) is located above the right arm rest.
- Press this button to immediately stop the motorized cutting drive.
- When the *hand emergency stop* is activated, the red LED (fig. 36.5) between the buttons (fig. 36.3 and 36.4) lights up.



Note:

After having activated the *hand emergency stop* STOP is shown inverted on the display (fig. 37).

- After having eliminated the danger and to continue sectioning, pull out the red button (fig. 57.2)
- The cutting drive can be started again.

Foot emergency stop:

- The second emergency stop installation is located in the foot pedal.
- Vigorously step on the foot pedal to immediately stop the motorized cutting drive.
- This emergency stop device is activated as long as the foot pedal is being stepped on.
- However, the LED (fig. 36.5) **does not** light up when the *foot emergency stop* is pressed.



Note:

After having activated the *foot emergency stop* STOP is shown inverted on the display (fig. 37).

- After having eliminated the danger and to continue sectioning, release the foot pedal.
- The cutting drive can be started again.

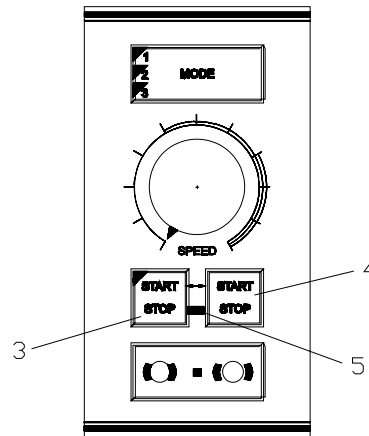

Fig. 36

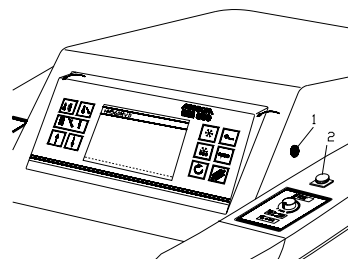

Fig. 36a

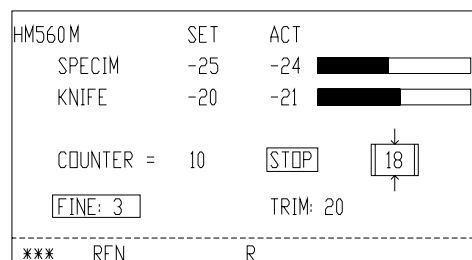

Fig. 37

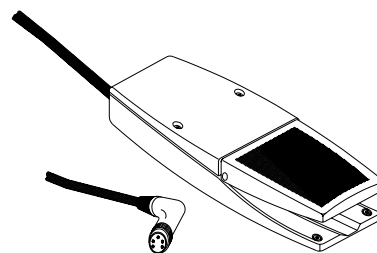

Fig. 38

2-9 DETACHING THE SPECIMEN

To detach a frozen specimen from the specimen chuck, choose the *detach* function.

- For this, press button (fig. 40.6).
- The plate of the fast freezing station warms up.
- Place the specimen chuck onto the plate.
- After a corresponding warm-up, the specimen can be removed from the specimen chuck.
- If the temperature is higher than +5°C, this function is turned off automatically.

HM560M	SET	ACT	
SPECIM	-25	-24	
KNIFE	-20	-21	
DETACH ACTIVE		-12	
COUNTER =	10	CONTIN	<input type="text" value="18"/>
<input type="text" value="FINE: 3"/>		TRIM: 20	

***	REN		R

Fig. 39

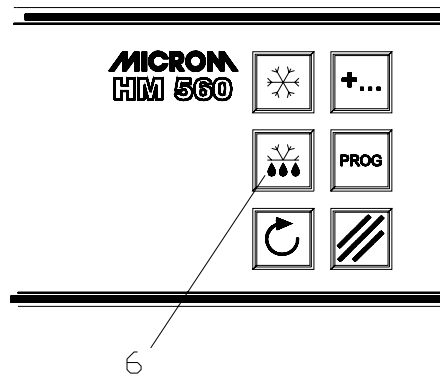

Fig. 40

2-10 INDICATION OF CUTTING PROCESSES

Further information on the cutting processes can be seen on the display.

Press the *scroll* button (fig. 41.5), to show the various functions one after the other.

The following information on the carried-out cutting processes of the instrument can be read on the info line of the display:

- number of sections
 - sum of section thicknesses
 - remaining travel to the front end position
 - real time
- Press the scroll button (fig. 41.5) until the required information lights up on the display.
 - If no information is required in this line of the display, press button (fig. 41.5) until this line is blank.

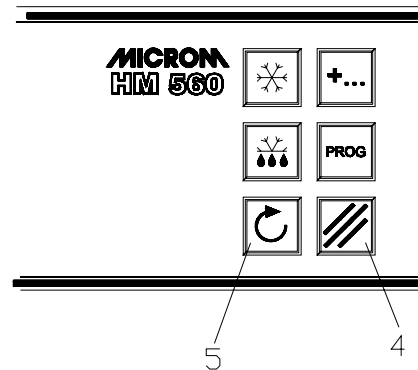

Fig. 41

2-10-1 SECTION COUNTER

- The section counter adds up the number of sections produced.
- After each downward movement of the specimen holder, the number on the section counter increases by 1.
- The counter can be reset to zero via button (fig. 41.4).

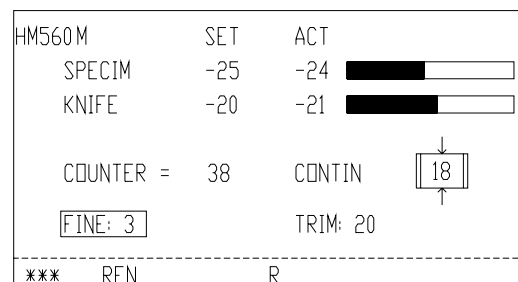

Fig. 42

2-10-2 SUM OF SECTION THICKNESSES

- This value shows the sum in microns of the sections already cut.
- Trimming values as well as sectioning values are added up.
- This value can be reset to zero via button (fig. 41.4).

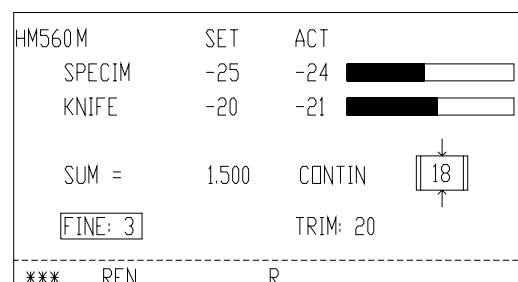

Fig. 43

2-10-3 REMAINING TRAVEL TO FRONT END POSITION

- This value shows the distance in microns, which is left for sectioning.
- When the knife carrier is in the rear end position, the display shows 48 000 µm. This number decreases the closer the knife carrier moves towards the front.



Note:

If no further feed is possible anymore, the display automatically shows the remaining travel, independently which information on the sectioning processes, e.g. number of sections or sum of section thicknesses, was chosen before.

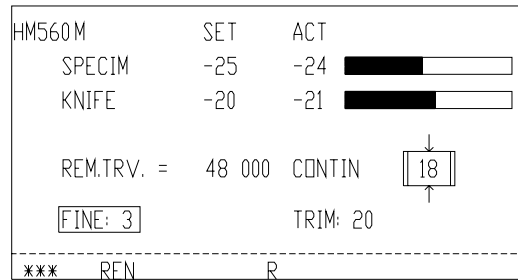

Fig. 44

2-10-4 REAL TIME

The real time is shown here.

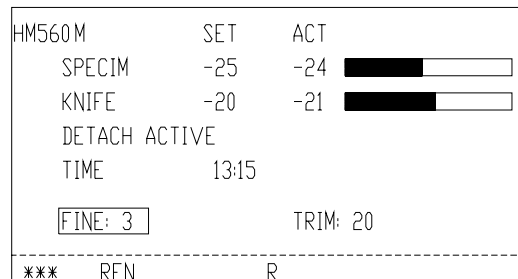

Fig. 45

2-11 SETTING THE REAL TIME, WAKE TIME AND ACTIVE TIME

2-11-1 SETTING THE REAL TIME

- Press button (fig. 47b.2) once.
- To change the instrument's real time at intervals of one minute, press the UP or DOWN button (fig. 47d.5 or 47d.6).

HM560M	SET	ACT	
SPECIM	-25	-24	
KNIFE	-20	-21	
COUNTER =	10	REAL TIME	11:25
FINE: 3		TRIM: 20	

***	REN	R	

Fig. 46

2-11-2 SETTING THE WAKE TIME

- Press button (fig. 47b.2) three times.
- To change the WAKE time at intervals of 15 minutes, press the UP or DOWN button (fig. 47d.5 or 47d.6).

After having reached the WAKE time, the instrument switches over to the active status.

HM560M	SET	ACT	
SPECIM	-25	-24	
KNIFE	-20	-21	
COUNTER =	10	WAKE TIME	8:00
FINE: 3		TRIM: 20	

***	REN	R	

Fig. 46a

2-11-3 SETTING THE ACTIVE TIME

- Press button (fig. 47b.2) four times.
- To change the ACTIVE time at intervals of 1-hour-steps (1 to 9 h), press the UP or DOWN button (fig. 47d.5 or 47d.6).

The set ACTIVE time is only valid when the instrument has left the sleep status after having reached the START time. Then the set ACTIVE time will be prolonged whenever pressing a key or turning the handwheel.



Note:

If the ACTIVE time has been passed and the instrument is in the sleep status and has been activated afterwards by the operator, the default value of 1 h is now valid again.



Note:

Further menu steps are relevant for service technicians only.

2-12 DEFROSTING

2-12-1 SETTING THE DEFROSTING TIME

- Press button (fig. 47b.2) twice.
- To change the instrument's defrosting time at intervals of 15 minutes, press the UP or DOWN button (fig. 47d.5 or 47d.6).



Note:

Defrosting can only be carried out at the set defrosting time, if the real time is set correctly (see part 2-11).

HM560M	SET	ACT	
SPECIM	-25	-24	
KNIFE	-20	-21	
COUNTER =	10	DEFR. TIME	22:45
FINE: 3		TRIM: 20	

***	REN	R	

Fig. 47

2-12-2 DEFROSTING CYCLE

Every 24 hours the evaporator in the rear part of the microtome chamber is defrosted automatically.

- During the defrosting cycle, the display (fig. 47a) shows DEFROST in the upper line.
- It is advisable to set the time of the defrosting cycle not during routine working time (see part 2-12-1).
- According to the frost built-up, a defrosting cycle normally takes approx. 40 min.

HM560M	SET	ACT	DEFROST
SPECIM	-25	-24	
KNIFE	-20	-21	
COUNTER = 0		CONTIN	
FINE 3		TRIM: 20	

***	REN	R	

Fig. 47a

- **Immediate defrosting** can be carried out at any time by pressing the RESET button (fig. 47b.4) and additionally the button (fig. 47d.2) (specimen temperature).
- Before starting the immediate defrosting, it is absolutely necessary to remove section waste.



Note:

When an immediate defrosting is carried out, the instrument is "actively heated", i.e. the heatings of the instrument are turned on. Knife carrier, specimen clamping as well as the fast freezing stations are heated.



Caution:

Remove the specimen from the chamber when defrosting is carried out. The temperature inside the chamber rises considerably and thus the specimen would be damaged.

2-12-3 INTERRUPTING A DEFROSTING CYCLE

If needed, the daily defrosting can be interrupted or cancelled.

- For this, press button (fig. 47d.3) (knife temperature) together with the RESET button (fig. 47b.4).
- The interrupted defrost cycle is indicated with INTR. in the status line (fig. 2.15) of the display (fig. 47c).



Note:

A cancelled or interrupted defrost cycle must be repeated later on, as otherwise the evaporator will cover completely with frost and cannot cool anymore (see immediate defrosting, part 2-12-2).

For this reason, the function INTERRUPT is automatically reset at the end of an interrupted defrosting (max. time approx. 1 h), i.e. the next defrosting is carried out again at the pre-selected defrosting time.

While INT. is active, neither the defrosting time nor the real time can be changed.

When INTR.ACT appears in the status line, this means that INTERRUPT was selected while defrosting should be otherwise be carried out and the next defrosting is carried out again at the next pre-selected defrosting time.

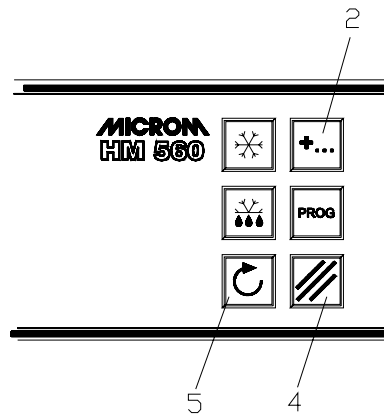

Fig. 47b

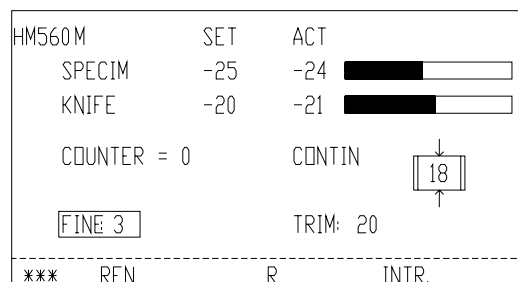

Fig. 47c

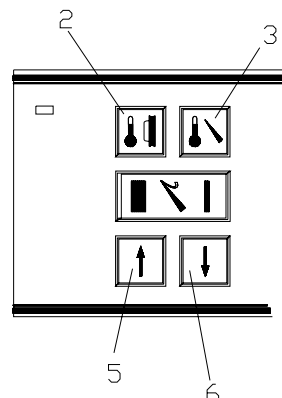

Fig. 47d

2-13 TURNING OFF THE FUNCTION RETRACTION

If needed, the function retraction can be turned off.

Turning off

To turn the function retraction off, the following preparation is necessary:

- Via the scroll button (fig. 48.5) select the blank status line (fig. 2.15) on the display.
- Then press the RESET-button (fig. 48.4) to turn the retraction off.
- The letters "REN" on the display go off.



Note:

The letter "R", however, might still be on. This function goes off only after having passed from the return travel again to the cutting movements via the handwheel.

Activating

- Via the scroll button (fig. 48.5) select the blank status line on the display.
- Then press the RESET-button (fig. 48.4) to turn the retraction on.
- The letters "REN" appear on the display.

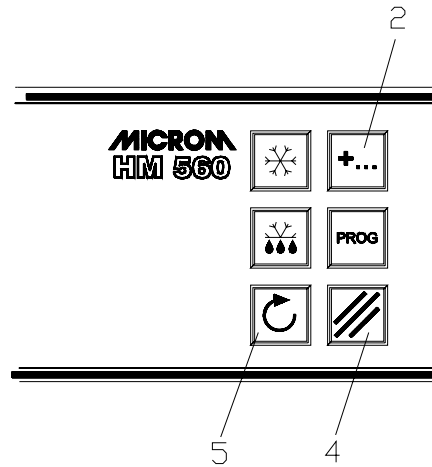

Fig. 48

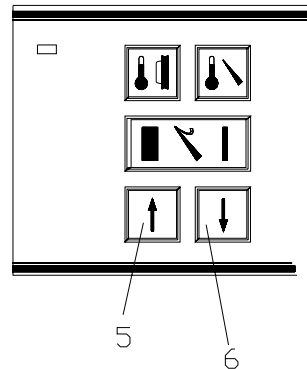

Fig. 49

2-14 CUSTOMER-SPECIFIC SETTINGS

The information on the display can be shown in various contrasts and in four different languages.

2-14-1 SETTING THE CONTRAST

- To set the contrast higher or lower, press the RESET-button (fig. 50.4). While the RESET-button is still being pressed, also activate button (fig. 53.4).
- Then the word CONTRAST is shown on the display (fig. 52.).
- To set the contrast lower, press the button DOWN (fig. 53.6).
- To set the contrast higher, press the button UP (fig. 53.5).
- To acknowledge the desired contrast, press the RESET-button (fig. 50.4).
- The display returns to its basic indication.

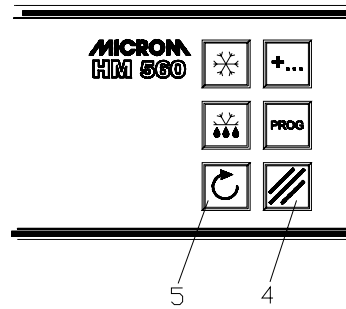

Fig. 50

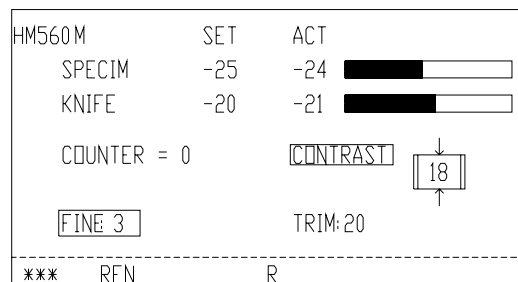

Fig. 52

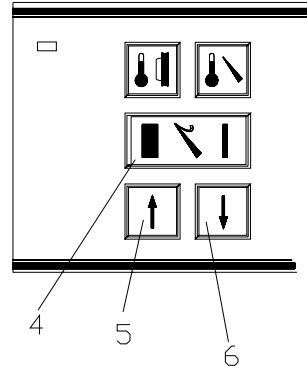

Fig. 53

2-14-2 SELECTING THE LANGUAGE

The information on the display can be shown in four different languages.

The following languages are available:

- German
- English
- French
- Spanish

- To select or change one of these languages, first turn off the power switch (fig. 6.1) of the instrument.
- When turning on the instrument again, keep the scroll button (fig. 54.5) pressed.
- The user enters the menu mentioned in part 2-14.
- Confirm the contrast setting via the RESET-button (fig. 54.4).

Now the desired language can be selected:

- The display shows as the first suggestion: LANGUAGE DEUTSCH (fig. 55).
- To choose another language, press the scroll button (fig. 54.5) until the desired language is shown in the respective national language on the display.
- Acknowledge the desired language via the button (fig. 54.4).
- Then the main menu for the service routine (fig. 56) is shown as well as "Next with SCROLL, confirm with RES." To quit the menu, please press the button (fig. 54.4).
- The display now shows the terms in the desired language.

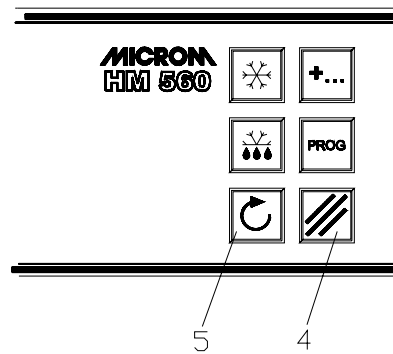

Fig. 54

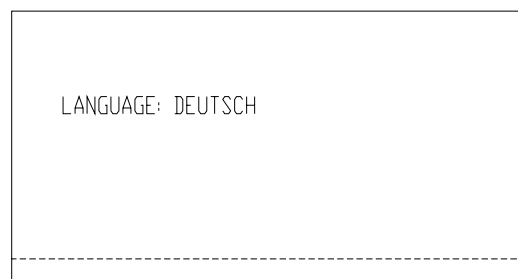

Fig. 55

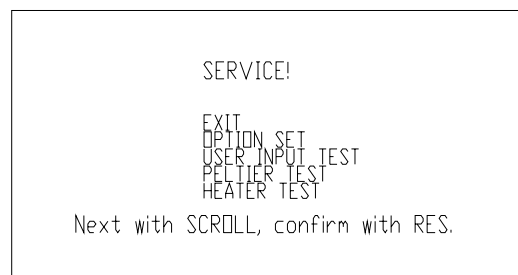

Fig. 56



Note:

If the menu has been used beyond the a.m. settings, the user enters service routine programs which can be operated by trained service technicians only.

2-15 TURNING OFF THE COOLING FUNCTION

With this OFF-function (fig. 56a), it is possible to turn off the major electric assemblies of the instrument (e.g. the compressors, the fast freezing element, the temperature control) without having to turn off the instrument on the main switch.

Consequently, the temperature in the cooling chamber increases. Now, the instrument can be used with certain restrictions in the same way as a rotary microtome under ambient conditions.

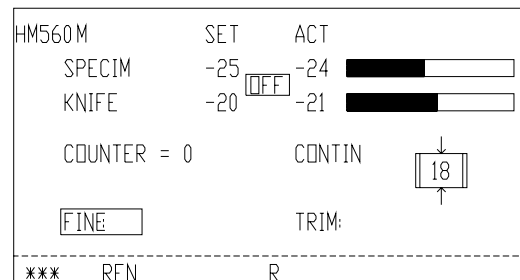

Fig. 56a

Turning on and off the cooling function:

- First press the RESET button (fig. 56b.4).
- While the RESET button is still being pressed, also press the button (fig. 56b.6).
- To activate the cooling function of the instrument again, press the buttons (fig. 56b.4) and (fig. 56b.6) once more.

For further specimen processing, let the instrument cool down accordingly.

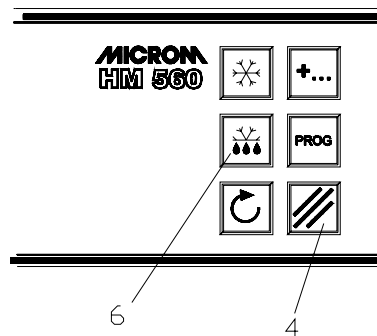

Fig. 56b

2-16 ILLUMINATION OF THE COOLING CHAMBER

To illuminate the cooling chamber, a fluorescent lamp is located in the handle of the sliding window.

- The fluorescent lamp is automatically turned on when the instrument is turned on.
- The lamp remains on as long as the instrument is in its active status (see standby status, part 2-3).
- Used lamps can be changed by the user himself (see part 5-3).

2-17 ADJUSTING THE OPERATING PANEL

For better looking at the display and for the ergonomical operation of the buttons, the user can adjust the angle of the console up to approx. 15°.

- Press the knob (fig. 57.1) on the right side of the console.
- Then take the console on the right and left side in your hands and swivel the console forwards or backwards into the desired position.

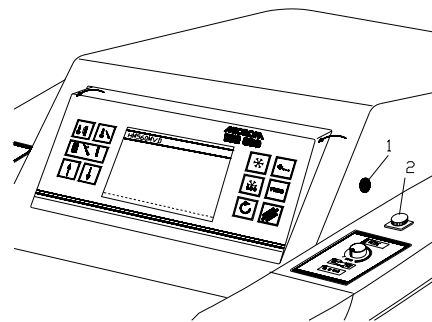

Fig. 57

2-18 SPECIMEN HOLDER, FREEZING-ON AND SPECIMEN ORIENTATION

2-18-1 SPECIMEN HOLDER, FREEZING-ON

There are several possibilities to freeze on specimens.

Various specimen chucks are available. Round specimen chucks can be supplied with a diameter of 30 mm and 40 mm and rectangular specimen chucks with a size of 50, 55, 60 and 70 mm. Special sizes on request. Fig. 58 shows a variety of specimen chucks and cryo molds. (See 2-21-2).



Note:

Besides the usual method of freezing specimens from above on the specimen chuck, it is highly recommendable to apply the below-described method by using cryo-molds (fig. 58).

- Put the cryo mold (fig. 59.2) onto the freezing station (fig. 59.1).
- Place fresh tissue into the spring of the cryo mold (fig. 59.2). The surface of the tissue has direct contact with the cold fast freezing plate (fig. 59.1).
- Fill freezing compound into the cryo mold (fig. 59.2) so that the spring is filled well.
- Put the chuck with the clinging grooves downwards (fig. 59.3) onto the cryo mold (fig. 59.2) which is filled with tissue and freezing compound.
- To accelerate the freezing, put the heat extractor (fig. 59.4) onto the specimen chuck (fig. 59.3) from above.



Note:

Within approx. 40 sec. the tissue will be frozen through.

- Remove the specimen chuck (fig. 59.3) together with the cryo mold (fig. 59.2) from the fast freezing plate.
- Insert the chuck with the cryo mold into the specimen holder on the microtome and clamp it.
- Open the cryo mold (fig. 59.2) by pressing the two grips (fig. 59.5) and remove it from the chuck with specimen.
- After having oriented the specimen (see part 2-18-2), the specimen can be sectioned.

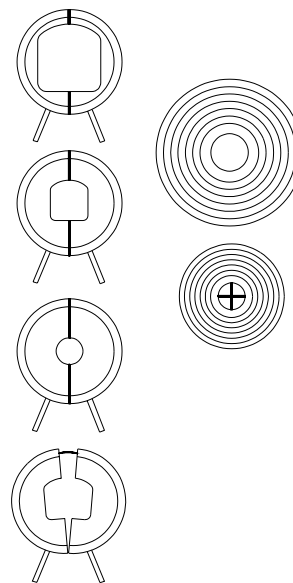

Fig. 58

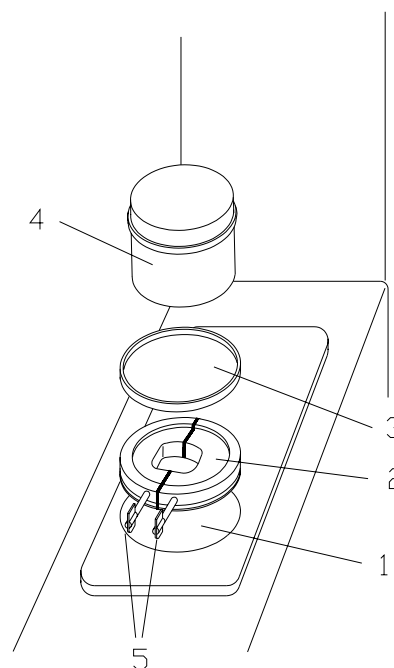

Fig. 59



Note:

The upper side of the freezing station must not be covered by frost or ice. To avoid this, use acetone, ethanol or the like.

2-18-2 SPECIMEN ORIENTATION

In many cases, the orientation of the specimen in relation to the cutting edge would be advantageous.

This can easily be done by means of the orienting specimen holder on the microtome.

- Before the specimen chuck can be inserted, loosen the clamping lever (fig. 60.2) upwards.
- Insert the specimen chuck and clamp it via the clamping lever (fig. 60.2).



Note:

The clamping mechanism can be adjusted in case the chucks cannot be clamped properly.

- For this, turn the adjusting ring (fig. 60.5) by means of the enclosed pin (fig. 60.6) (see standard equipment part 2-21-1).
- For a tighter clamping, turn the ring to the right side.
- For a looser clamping, turn the ring to the left side.
- To orient the specimen, loosen the orienting lever (fig. 60.1).
- Via the adjusting knobs (fig. 60.3 and 60.4), the specimen clamping can be moved into various directions.



Note:

When the adjusting knob (fig. 60.4) for specimen orientation is activated, a slight lock-in position can be noticed during each rotation. The entire adjusting range includes four rotations in either direction. The middle lock-in position marks the zero position.

- After having oriented and aligned the specimen, press the orienting lever (fig. 60.1) upwards.

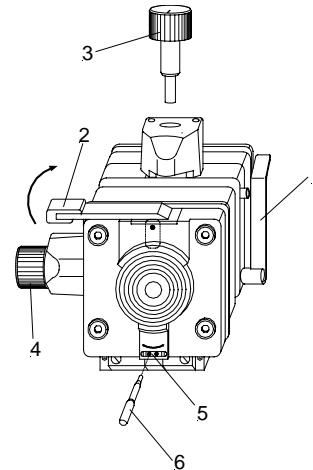

Fig. 60

For the further specimen orientation, the specimen chuck can be rotated by 360°.

- Slightly loosen the clamping lever (fig. 60.2) upwards.
- Turn the specimen chuck with specimen as needed.
- Then bring the clamping lever (fig. 60.2) back in its clamping position.

- Pull the adjusting knob (fig. 60.3) upwards to facilitate the taking off of sections by means of a slide.

2-19 KNIFE CARRIERS

2-19-1 STANDARD KNIFE CARRIER SM

The **standard knife carrier SM** takes up commercially available conventional knives with c- and d-profiles as well as the disposable blade holder SE.

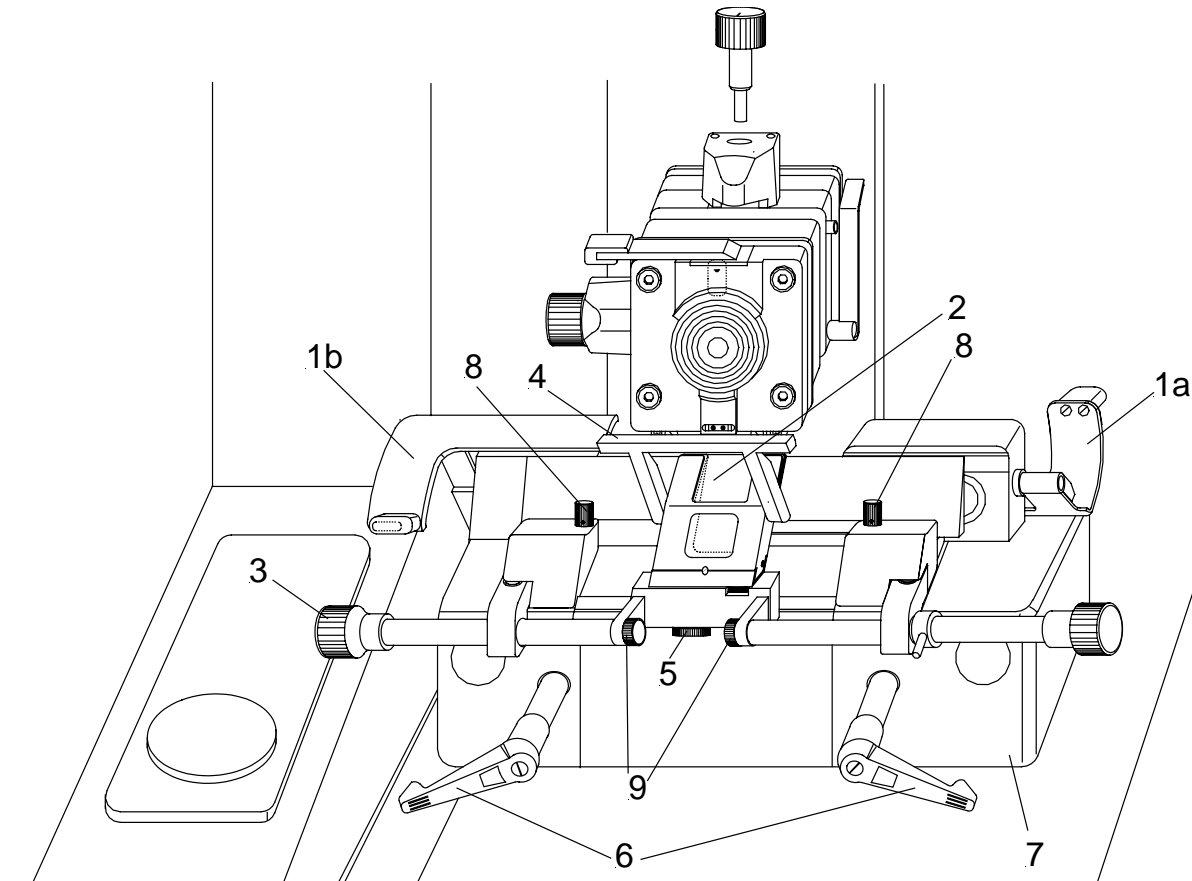

Fig. 61

Inserting the knife:

- The knife is inserted into the knife carrier from above.
- For this, swivel both knife guards (fig. 61.1a and 61.1b) over the knife carrier towards the microtome.
- Via the knob (fig. 61.3), remove the anti-roll plate (fig. 61.2) together with the finger protecting bow adapted to the anti-roll hood (fig. 61.4) from the knife carrier.
- Insert the knife.



Danger:

When the knife guards are open, the fixing force for the knife is strongly reduced. However, the knife is still pulled towards the magnetic surfaces with some force. Be careful, when inserting the knife.

- Swivel the knife guards (fig. 61.1a and 61.1b) back over the knife.



Note:

With this movement, the holding magnets, which clamp the knife in place, are brought into their correct position. The knife is now fixed in its position.

- Via the knob (fig. 61.3) put the anti-roll plate (fig. 61.2) against the knife.
- Place the knife guard middle part (fig. 61.4) over the knife blade.

If the cutting area of the knife is no longer usable, the knife can be moved:

- Open the knife guards (fig. 61.1a and 61.1b) and move the knife to the left or right side as required.
- Clamp and fix the knife again via the knife guards (fig. 61.1a and 61.1b).



Danger:

To avoid the danger of injury on the knife during adjustment of specimen, always position the knife guards (fig. 61.1a and 61.1b as well as fig. 61.4) over the blade edge.

Height adjustment of the knife:

- Open the knife guards (fig. 61.1) to loosen the fixation of the knife.
- Via the knurled screws (fig. 61.8) adjust the height of the knife so that the blade corresponds with the red marking line.



Note:

Please note the parallel alignment of knife edge and edge of the anti-roll plate.

Putting the anti-roll device holder against the non-cutting edge of the knife:

- Loosen the knurled screws (fig. 61.9) to put the anti-roll device holder against the non-cutting edge of the knife.
- Press the anti-roll device holder onto the knife.
- Fasten the knurled screws (fig. 61.9) again.

Fine adjustment of the anti-roll device:

- The fine adjustment of the anti-roll device is carried out via the knurled screw (fig. 61.5).
- The parallel positioning between knife edge and anti-roll plate is carried out via another knurled screw on the right side of the knurled screw (fig. 61.5).

Selecting the clearance angle:

- Loosen the levers (fig. 61.6).
- Swivel the upper part of the knife carrier on the base (fig. 61.7) until the desired clearance angle is reached.
- The clearance angle can be read on the scale on the left side on the base.
- Bring the levers (fig. 61.6) into clamping position.
- The selected clearance angle is now fixed in its position.



Note:

Usable cuts are only achieved at a clearance angle of 8° to 12°!

Adjusting the flat lever handles (fig. 61.6)

The position of the flat lever handles (fig. 61.6) can be adjusted in 30° steps.

- Slightly pull out the handles and turn them further into a more favorable position.
- The handles must lock into place again.

2-19-2 DISPOSABLE BLADE HOLDER SE

The disposable blade holder SE takes up all commercially available low profile blades with a dimension of 80 x 8 mm and a facette angle of approx. 35° and as another version it takes also up high profile blades.

The disposable blade holder SE is inserted into the standard knife carrier SM.

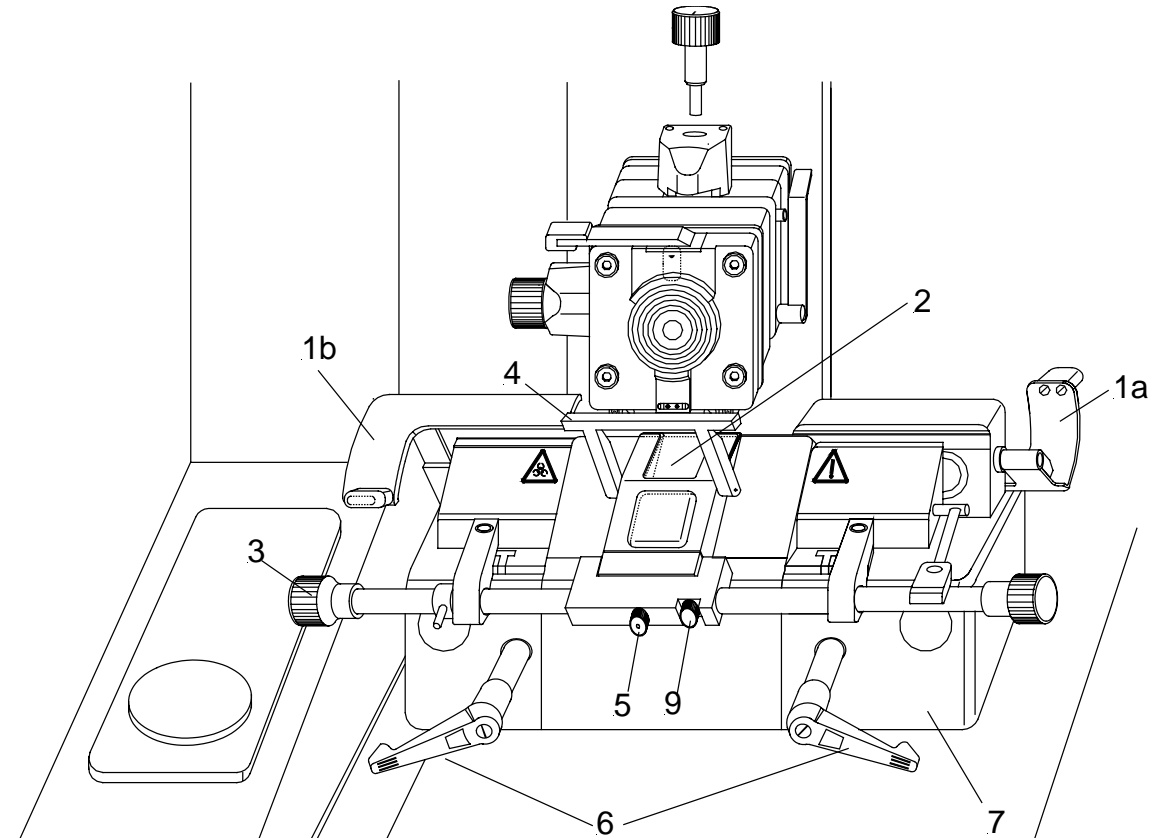

Fig. 62

Inserting the blade:

- Open the left and right knife guard (fig. 62.1a and 62.1b).
- Open the clamping lever (fig. 62.8) upwards.
- Insert the blade from the left side into the slot behind the clamping plate (fig. 62.9) as far as possible.
- Use the attached brush or a similarly shaped object to insert the blade in its entire length behind the clamping plate (fig. 62.9).
- Close both knife guards (fig. 62.1a and fig. 62.1b) so that the fixation force of the magnets are applied on the disposable blade holder.

**Danger:**

When activating the clamping lever (fig. 62.8) with a strong or jerky movement, the disposable blade holder SE might be suddenly dislocated. For this reason, always keep both knife guards (fig. 62.1a and 62.1b) closed.

- Close the clamping lever (fig. 62.8) downwards to clamp the blade.

If the cutting area of the blade is no longer usable, the blade can be moved:

- The blade itself is clamped solidly into the disposable blade holder. The complete holder is moved.
- Open the knife guards (fig. 62.1a and 62.1b) and move the blade to the left or right side as required.
- Clamp and fix the blade holder again via the knife guards (fig. 62.1a and 62.1b).

**Danger:**

To avoid the danger of injury on the blade during adjustment of specimen, always position the knife guards (fig. 62.1a and 62.1b as well as fig. 62.4) over the blade edge.

Fine adjustment of the anti-roll device:

- The fine adjustment of the anti-roll device is carried out via the knurled screw (fig. 62.5).
- The parallel positioning between blade and anti-roll plate is carried out via the knurled screw (fig. 62.9).

Selecting the clearance angle:

- Loosen the levers (fig. 62.6).
- Swivel the upper part of the knife carrier on the base (fig. 62.7) until the desired clearance angle is reached.
- The clearance angle can be read on the scale on the left side on the base.
- Bring the levers (fig. 62.6) into clamping position.
- The selected clearance angle is now fixed in its position.



Note:

Usable cuts are only achieved at a clearance angle of 8° to 12°!

Adjusting the flat lever handles (fig. 62.6)

The position of the flat lever handles (fig. 62.6) can be adjusted in 30° steps.

- Slightly pull out the handles and turn them further into a more favorable position.
- Then the handles must lock into place again.

2-19-3 MODIFICATION FROM STANDARD KNIFE CARRIER SM TO DISPOSABLE BLADE HOLDER SE

For the cryostat HM 560 series a knife carrier system is used which is modified depending on the application of either a standard knife or disposable blades.

The basic part consists of a knife carrier which is suitable for standard knives. Optionally, a blade holder for disposable blades can be inserted into this basic part. For this, a minor modification becomes necessary.

- Remove the knife.
- Loosen the fastening screws (fig. 63a.11) of the anti-roll guide (fig. 63a.10) from above.
- Remove the anti-roll guide (fig. 63a.10).
- Pull off the stands (fig. 63a.13) in an upward direction.
- Remove the wedge rail (fig. 63a.7).



Note:

Carefully keep the two stands (fig. 63a.13) as well as the wedge rail (fig. 63a.7). These parts will be needed again when modifying from disposable blade holder SE to standard knife carrier SM.

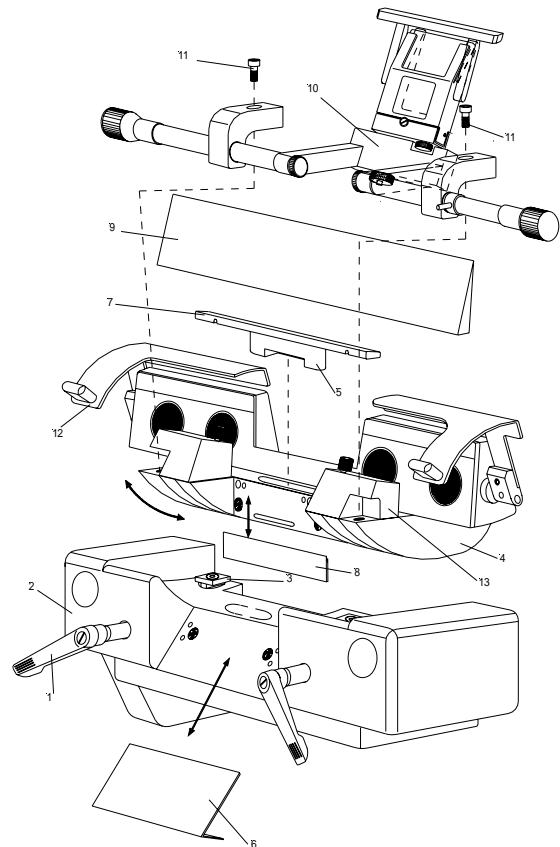

Fig. 63a

- Fasten the anti-roll guide (fig. 63b.10) for the disposable blade holder SE via the screws (fig. 63b.11).
- Tilt the knife guards (fig. 63b.12) upwards and place the disposable blade holder SE (fig. 63b.9) against the holding surfaces.



Note:

A complete and secure fixation is only achieved, when the knife guards (fig. 63b.12) are put over the disposable blade holder SE (fig. 63b.9).

- Adjust the anti-roll guide (fig. 63b.10) onto the disposable blade holder SE.

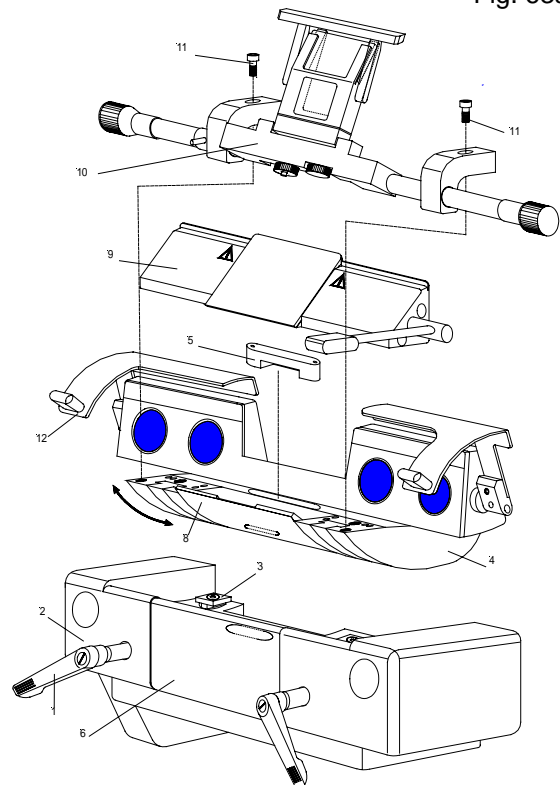

Fig. 63b



Danger:

Before inserting and clamping the blade into the disposable blade holder SE, left knife guard for the fixation (fig. 63b.12) must be placed over the disposable blade holder SE on the left side. This way, the disposable blade holder SE does not tilt to the right side when clamping the blade.

2-20 ERROR CODE INDICATION

The instrument has an error code indication to define faster and better possible malfunctions.

The error codes describe so-called system errors. Additionally, error messages are shown on the display as text messages, e.g. when the temperature sensors are faulty, when the end position of the knife carrier has not been reached, when there is a high pressure in the cooling system and when the function of the automatic approach system is faulty (see part 2-7-3).



Note:

If an error code appears on the display of your instrument, please note it down and contact your sales organisation where you bought the instrument or directly contact MICROM International GmbH.

2-20-1 DEFINITION OF THE ERROR CODES

ERROR OF A TEMPERATURE SENSOR

Four different error codes, which indicate a defect on a temperature sensor, can appear on the display. The message is shown on the second line from below on the display (fig. 64).

1. 'SPECIMEN SENSOR ERR'

The instrument recognizes a faulty operation on the specimen temperature sensor, which is placed in the specimen head.

2. 'KNIFE SENSOR ERR'

The instrument recognizes a faulty operation on the knife carrier sensor, which is placed in the knife carrier base.

3. 'FREEZE SENSOR ERR'

The instrument recognizes a faulty operation on the sensor of the fast freezing station, which is placed inside the fast freezing plate.

4. 'EVAP SENSOR ERR'

The instrument recognizes a faulty operation of the defrost limiting sensor, which is placed between the fins of the evaporator.



Note:

However, you can work to a certain extent with the instrument until the operational fault is removed by a trained service technician.

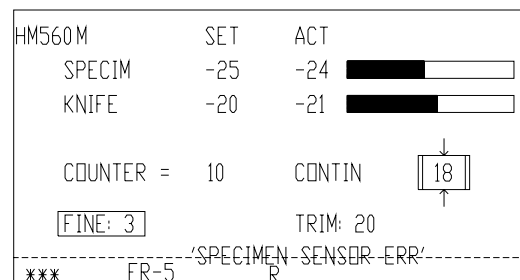

Fig. 64

ERROR CODE 'NO END POSITION'

Before turning on the instrument on the main switch, it carries out an automatic travel calibration of the knife carrier. The knife carrier is brought into that position which has the longest distance to the specimen head.

If there is an operational fault during this process, e.g. debris or frost impedes the knife carrier movement, this is shown via the message 'NO END POSITION' and means that a calibration was not carried out.

A service technician must be called.

Caution:

After pressing the RESET-button (fig. 65.4), you can work with the instrument again. However, be sure that there will not be a collision between knife carrier and vertically moving specimen head.

ERROR CODE 'HIGH PRESSURE'

The pressure conditions in the cooling system are permanently monitored. If a fixed pressure barrier is exceeded due to excessive high ambient temperatures (see part 1-2) or due to a malfunction of the cooling system, the cooling system is turned off. Additionally, the error message 'HIGH PRESSURE' is shown on the display.

In this case, make sure that the permissible operating conditions are adhered to. Afterwards, acknowledge the error message by pressing the scroll button (fig. 65.5). After the pressure has decreased, the cooling system turns on automatically.

In case, this error occurs repeatedly, the cooling system must be checked by a service technician.

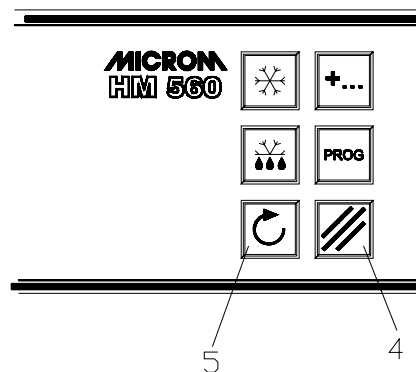

Fig. 65

SYSTEM-ERROR

The instrument is designed to check for internal system errors.

In case such an error is recognized, it is shown as '**ER-10**' to '**ER-16**' for approx. 5 sec. in the middle of the display.

The recognition of such an error leads to an automatic RESET-process.

The cause for this might be a temporary fault.



Note:

In case one of these messages occur more than once, please note down the error code and contact a service technician.

2-21 ACCESSORIES**2-21-1 STANDARD EQUIPMENT**

The microtome cryostat HM 560 M Cryo-Star is equipped with the following accessories:

	Cat. No.
2 specimen chucks, 30 mm round	715600
1 specimen chuck, 40 mm round	715610
1 Allan key 2,5 mm	362220
1 Allan key 5 mm	362260
1 Allan key 6 mm	362120
1 magnetic brush	334000
1 cryostat oil no. 407 100 ml	350040
1 freezing compound 100 ml for low and medium temperatures	350100
1 section waste tray	406360
1 brush shelf	449880
1 screwdriver	362270
2 carrying handles, front	570360
2 carrying handles, rear	424910
1 pin for specimen orientation	242530
1 drain hose	585030
1 foot pedal	640280
1 instruction manual	387370

2-21-2 ADDITIONAL EQUIPMENT (OPTIONAL)

Cat. No.

Specimen chucks:

∅ 30 mm	715600
∅ 40 mm	715610

Cryo-Molds:

10 mm	570400
15 mm	570380
22 mm	570390

Knife carriers with anti-roll guide:

Standard knife carrier SM	705700
Disposable blade holder SE	705710

Heat extractor	524510
----------------	--------

Cryostat Stages:

Cryostat Stage with mechanical height adjustment	956100
Cryostat Stage with motorized height adjustment	
100 V/50-60 Hz	956110
115 V/60 Hz	956120
220-230 V/50-60 Hz	956130
240 V/50 Hz	956140

3 THEORY OF OPERATION

3-1 SPECIMEN AND KNIFE CARRIER COOLING, DEFROSTING

The chamber, the knife carrier and the specimen head are cooled by two refrigeration machines. In the rear area of the microtome chamber is an evaporator which the cold coolant flows through as well as through the knife carrier and the specimen head. Due to the heat extraction from the microtome chamber a cooling down of the knife carrier to -35°C can be achieved.

By means of an installed thermo-electrical element, controlled temperatures down to -50°C can be achieved on the specimen head.

On the left side of the microtome chamber, there are freezing stations which can be cooled down to a temperature of -30°C .

The instrument is equipped with an active deep freezing device.

The station can be cooled down to -60°C by means of a Peltier cooling element.

Use the heat extractor to accelerate the freezing of the specimen.

The temperature of the knife carrier can be adjusted continuously down to -35°C . For this, pre-select the desired temperature as set value on the control panel. The actual value is constantly measured and sent to the control unit.

The specimen temperature control serves for a more efficient working with the cryostat. For various specimens, different cutting temperatures can be achieved very quickly.

After having cut, the specimen can be detached quickly from the chuck by using the function *detach*. Another possibility to detach the specimen is to warm it up outside the chamber.

The specimen temperature control is supplied via the same circuit as the evaporator and the knife carrier. The coolant flows through the cooling head which is designed as a small evaporator chamber and cools it.

A thermo-electrical element is coupled with the evaporator housing on the specimen head. Via a set value input for the specimen head on the control panel, the electronics control the thermo-electrical element at any desired temperature between $+10^{\circ}\text{C}$ and -50°C .

Inevitably, when working on the microtome the dry cold air of the microtome chamber mixes with the warm humid air outside the chamber. Frost forms on the finned evaporator. The increasing thickness of the frost reduces the efficiency of the evaporator. For this reason, the daily defrosting of the evaporator becomes necessary. To carry out the defrosting cycle, a heating warms the evaporator from below.

Set the time of the daily defrosting on the control panel. The period of the defrosting takes approx. 40 min. and varies according to the thickness of the frost.

Possible frost built-up on the microtome or on the knife carrier are not removed by defrosting the instrument. However, the frost recedes after defrosting as now the evaporator is fully efficient again.

In addition, the instrument is equipped with an immediate defrosting function. All areas, which are actively cooled during normal operation, are heated. Together with the drying process, the immediate defrosting takes approx. 90 min.

To avoid condensation the sliding window is heated when closed.

3-2 CUTTING MOVEMENT

The microtome of this cryostat is a rustproof rotary microtome.

The cutting movement is carried out by turning the handwheel.

The rotary movement results in the vertical movement of the specimen clamp and in the horizontal movement of the knife carrier.

Sectioning is carried out by knives or blades, which must be adjusted and fixed on the knife carrier.

With the downward movement of the specimen, sectioning is carried out (cutting movement).

The upward return travel of the specimen is carried out by turning the handwheel further in a clockwise direction. During this return travel, the knife carrier together with the knife is drawn back automatically to protect knife and specimen. If required, the function retraction can be turned off.

The selected section thickness is delivered at the upper reversal point of the return travel.

The number of the sections made can be shown on the section counter on the display. After each downward movement of the specimen holder, the number on the section counter increases by 1.

The sum of the sections carried out can also be seen on the display. For this, trimming values and sectioning values are added up. Section counter and sum of section thicknesses can be reset to zero at any time by means of the RESET-button.

Moreover, the remaining travel to the front end position can also be shown on the display. The remaining travel, which is still available for sectioning, is shown in microns. If the knife carrier is in the back end position, the display shows 48 000 μm . This number decreases, the further the knife carrier is moved towards the front, i.e. in the direction of the specimen.

**3-3 KNIFE CARRIER COARSE FEED
AND TRIMMING FUNCTION**

After changing the specimen or moving the knife or knife carrier, it is necessary to adjust the knife edge to the specimen again. This can easily be done by means of the coarse feed and the trimming function.

After the specimen and the knife are adjusted, further gradual feed for trimming can be carried out by pressing the button for trimming, which is available as *pulse function*. If the pulse function is chosen, the knife carrier moves forwards by the pre-selected trimming value whenever pressing the button for trimming.

3-4 AUTOMATIC APPROACH SYSTEM

The automatic approach system is used for the fast and exact approach of the specimen towards the knife edge.

The function of the automatic approach system is limited to the temperature range between -5°C and -35°C.

Beyond these temperature limits the automatic approach system does not work (see part 2-7-3).

The automatic approach system uses the intrinsic capacity of the specimen to notice a first contact between specimen and knife edge. If specimen and knife edge get in contact with each other, a very low current is measured via a pre-amplifier, which is placed directly behind the specimen holder. The signal form of the detected current is transferred via the outlet of the pre-amplifier to the micro-processor. A corresponding software recognizes the threshold value causing an immediate interruption of the horizontal drive. The threshold value is also determined regarding the temperature.

The optimal function of the automatic approach system is based on the fact that the knife is conductively connected with the knife carrier base, whereas the specimen holder is separated by an isolating piece.

3-5 **MOTORIZED CUTTING DRIVE**

The motorized cutting drive facilitates routine work and ensures an even cutting speed also for harder specimens.

When using the motorized cutting drive a regulated D.C. motor works on the handwheel of the cryostat microtome by means of an electromechanical clutch and a reduction gear. The speed of the motorized drive can be pre-selected continuously on the operating controls from 0 to 250 mm/s. The selected speed will be carried out in the cutting window. Outside the cutting window a higher return speed is determined by the electronic control unit. Use either the operating controls or the foot pedal to turn on/off the drive.

The limits of the cutting window can be changed continuously and can be adjusted to the specimen. This can be done in an automatic mode or also by manual settings (see part 2-8-1).

Three operating modes for the motorized cutting drive are available. When in operating mode <interval stroke>, the cutting drive only moves as long as the button START/STOP or the foot pedal is pressed. The movement can be stopped in any position.

When in operating mode <single stroke> the cutting drive moves from the starting position to the next lower reversal point.

When in operating mode <continuous stroke>, an unlimited number of sections is carried out. To stop the continuous stroke, press the button START/STOP or the foot pedal. The cutting drive will stop after reaching the next lower reversal point.

In case of danger, the motor drive can be stopped in every operating mode by pressing the emergency stop button or the emergency stop in the foot pedal. Continue sectioning pull out the emergency stop button or unlock the emergency stop in the foot pedal (see part 2-8-6).

4 WORKING WITH THE CRYOSTAT

**4-1 PREPARATIONS ON THE
MICROTOME AND INSIDE THE
COOLING CHAMBER**

Before sectioning, the knife carrier and the cooling chamber should be at a stable temperature around the desired cutting temperature.

Select a knife carrier and specimen temperature corresponding with the consistency of the specimen that should be sectioned.

All tools which are necessary to take off sections or to manipulate the specimen must also be cooled, as the section will stick to them. For this reason, the required working accessories should always be stored on the shelves or brush tray in the microtome chamber.

The heated sliding window should be closed during breaks and while preparing work to avoid warm air getting into the chamber. Consequently, more favorable work conditions with a lower frost built-up on the microtome and knife are achieved.

4-2 FREEZING-ON THE SPECIMEN

The specimen is frozen-on to the specimen chuck with clinging groves by means of a freezing compound.

To freeze-on specimens, use the fast freezing device on the left side of the chamber.

Press the button *Freeze Down* in due time before the freezing-on so that the active cooling surface can adjust itself to the corresponding temperature. It will take approx. 2 - 3 min. until the cooling surface reaches a temperature of -60°C (see part 2-5-3).

Besides the usual method of freezing specimens from above on the specimen chuck, it is highly recommendable to apply the below-described method by using cryo-molds (fig. 58).

The cryo-mold is placed onto the fast freezing plate. Afterwards, fresh tissue is placed into the sparing of the cryo-mold. The surface of the tissue is in direct contact with the cold fast freezing plate. Then fill freezing compound into the cryo-mold so that the sparing is filled well.

Place the specimen chuck, with the clinging groves downwards onto the cryo-mold which is filled with tissue and freezing compound. For faster freezing through, place the heat extractor onto the specimen chuck from above. The tissue is frozen through within approx. 40 sec.

Then remove the specimen chuck together with the cryo-mold from the fast freezing plate. Insert the specimen chuck with cryo-mold into the specimen holder on the microtome. Open the cryo-mold by pressing the handles together and remove it from the specimen and specimen chuck.

This method guarantees that the surface of specimen, which is later to be sectioned, gets in direct contact with the very cold spot of the fast freezing station. This allows a higher freezing speed, especially on the section surface resulting in a reduced formation of ice crystals in the tissue.

4-4 ORIENTATION AND TRIMMING

Clamp the specimen chuck together with the frozen specimen into the specimen holder.

For this, tighten the clamping lever (fig. 60.2) and insert the specimen chuck into the specimen holder. Tighten the clamping lever again.

Loosen the orienting lever (fig. 60.1) to have the possibility to adjust the specimen parallel in relation to the cutting edge by means of the adjusting knobs (fig. 60.3 and 60.4).

With the motorized coarse feed (see part 2-7-1) specimen and knife can roughly be adjusted.

The process of the first approach between specimen and knife edge can also be carried out via the automatic approach system (see part 2-7-3).

Then carry out a further gradual feed by using the function *trimming*. Turn the handwheel in a clockwise direction resulting in the first contact between knife and specimen. Continue this thus achieving the desired level.

Any waste should be wiped away in an upward direction with a brush.

A magnet is installed invisibly in the middle of the front internal chamber wall. For fast and ergonomical operation, the magnetic brush can be put there in an upright way.

**4-5 SECTIONING AND TAKING
OFF SECTIONS**

For sectioning, pre-select the desired section thickness by means of the buttons on the operating controls (see part 2-4). Put the anti-roll plate against the knife by means of the knob. Turn the handwheel in a clockwise direction or use the motorized cutting drive (see part 2-8) to carry out sectioning. The section slides into the space between the knife and the anti-roll guide.

Then remove the anti-roll guide by means of the knob. The section sticks to the knife surface. Transfer the specimen now onto a slide by using a brush or tweezers.

4-6 HOW TO AVOID MALFUNCTIONS

To cut usable sections, the following points are of utmost importance:

- Condition of the knife edge, probably move it horizontally to the left or right side.
- Check adjustment of anti-roll guide and correct it, if necessary.
- Carefully remove frost from front and rear part of the knife and from the anti-roll plate (i.e. with ethanol, acetone or the like).
- Tighten all clamping screws and clamping levers on the knife carrier and specimen holder.
- Select the appropriate knife carrier and specimen temperature according to the specimen.
- Select the appropriate freezing compound.

**Note:**

If the specimen was frozen with liquid nitrogen or similar freezing techniques, the specimen must adapt itself to the cutting temperature.

- Carefully select the required knife material and profile.
- Adjustment of knife height.
- Adjustment of proper clearance angle. Select a clearance angle of 8-12° according to the facet angle of a steel knife.
- Select a proper cutting speed: The harder the material, the slower the cutting speed!
- Take care in bringing knife and specimen together.
- The most protruding point of the specimen must be recognized for the optimal operation of the automatic approach system.
- The specimen must not be covered at all or too thick by freezing compound.

- Moreover, for the functionality of the automatic approach system and the automatic window, a certain conductivity must be given via the specimen chuck as well as from the knife edge to the microtome base.

For this reason, the original equipment such as knife carrier and specimen chucks should be used only.

- The specimen holder of the microtome is connected with a sensitive electronic detecting device. The temperature sensor on the left side of the microtome housing is also connected with such a device.

Malfunctions might occur after electrostatic discharges on one of the above-mentioned parts.

Recommendation: Before touching the specimen holder or temperature sensor, touch another metallic part, e.g. knife carrier, inner wall of chamber or waste tray to guarantee a safe discharge.

- When working with the active deep freezing device, sufficient time must have been passed to allow this device reaching a temperature of -60°C .

For optimal sectioning, the knife and anti-roll guide must be cleaned of paraffin waste. Only use a sharp knife and exactly adjust the anti-roll guide in relation to the knife edge.



CAUTION:

During defrosting, remove the specimens from the cooling chamber, as the temperature inside the chamber will increase.

Do not leave or store tissue inside the cryostat over a longer period. Due to a power failure or other unexpected malfunctions of the instrument, the specimen might be damaged.

5 MAINTENANCE OF THE CRYOSTAT

5-1 SHUTTING-OFF FOR CLEANING

Cleaning of the cryostat depends on how frequently the instrument is used. However, it is recommended to shut the instrument off every 6 - 8 weeks.

Please proceed as follows:

- Turn off the main switch; pull the main plug off.
- Remove the knife/blade from the knife carrier and store it in a knife case.
- Remove or suck off cold section waste.
- Remove section waste tray, specimen chucks and working tools. Loosen the two clamping levers on the knife carrier and pull them out. Then remove the knife carrier upwards.
- Again suck off cold section waste.
- The warming up of the microtome chamber can actively be accelerated by using a hair dryer.
- Clean and wash the cooling chamber with appropriate cleaning agents.
- The liquids from cleaning inside the cooling chamber can drain off via the outlet on the lower right side of the cooling chamber. For this, make sure that the attached hose is connected to the outlet and placed into an appropriate container.
- Open the stopper inside the chamber.



Note:

After cleaning, insert the stopper again as otherwise cold air leaks out while in operation and the instrument will cover with frost.

5-2 CLEANING AND CARE OF THE MICROTOME

- Carefully clean and dry the dismantled knife carrier.
- As there is condensed humidity inside the microtome, dry the microtome components inside the cooling chamber very carefully. For this, use a hair dryer.



Note:

For the examination and re-adjustment of the microtome a routine maintenance should be performed by trained service technician once a year.

5-3 CHANGING THE FLUORESCENT LAMP

The fluorescent lamp L8/12 of the cryostat is integrated in the grip (fig. 66.1) of the heated sliding window.

- Before exchanging the lamp, turn off the main switch and unplug the instrument.
- Open the sliding window halfway.
- Turn the two red knurled screws (fig. 66.2) which are placed on the right and left lower side of the sliding window in a counter-clockwise direction and remove them.
- Remove the grip (fig. 66.1) from the upper side of the sliding window.
- Turn the lamp by 90° forwards or backwards and remove it from the sockets (fig. 66.4).
- Insert the new lamp from above into the socket and turn it by 90°.

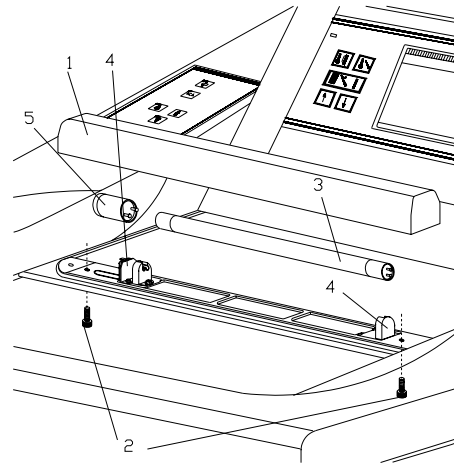

Fig. 66



Note:

Only use the lamp type L8/12, cat. no. 346190, which was installed in the factory.



Note:

Whenever exchanging the fluorescent lamp, please also exchange the starter S10 Philips (cat. no. 322710).

- Turn the starter (fig. 66.5) in a counter-clockwise direction and remove it from the socket.
- Insert the new starter into the socket.
- Turn the new starter clockwise until the starter is positively locked.
- Place the grip (fig. 66.1) onto the illumination ledge from above.
- Screw in the two red knurled screw clockwise from below and tighten them.
- Plug in and then turn on the instrument and check the illumination.

**5-4 DISPOSAL OF THE INSTRUMENT
AFTER FINAL SHUTDOWN**

After the final shutdown of the instrument, we recommend to contact a local recycling company for the disposal according to the national applicable regulations.



To be applied in the countries of the European Union and other European countries with a separate collecting system within the waste management.

The marking of the product and/or the respective literature indicates that, after its final shutdown, it must not be disposed of together with ordinary domestic waste.

- Please dispose of your instrument separately from other waste to not harm our environment and/or human health by uncontrolled waste disposal.
- Recycle your instrument to support the sustainable recycling of material resources.
- **Industrial users** should contact their suppliers and observe the conditions of the contract. This product must not be disposed of together with other commercial waste.
- **Please contact your supplier!!**